

A Globally Significant
AUSTRALIAN
Graphite Project

Investor Presentation: *Noosa Mining & Exploration Investor Conference, 18-20 July 2018*

Siviour Graphite Project

One of world's largest high-grade flake graphite deposits.

- **Mineral Resource: 80.6 Mt at 7.9% TGC for 6.4 Mt of contained graphite.**
- **Ore Reserve: 45.2 Mt at 7.9% TGC for 3.6 Mt of contained graphite.**



Investment Highlights

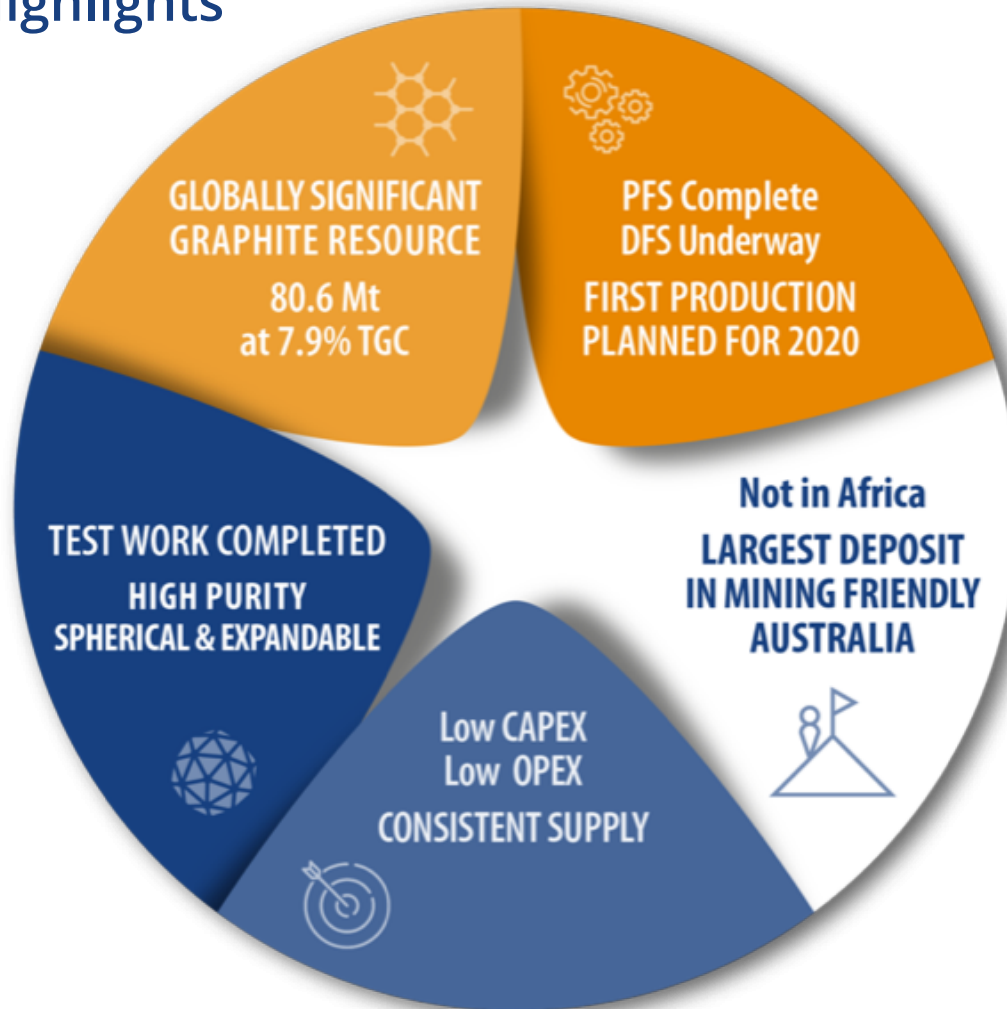

Renascor Market Information

Key Statistics	
Ordinary Shares	961M
Options on Issue (ex at 3c expire 31-Oct 2019)	115M
Unlisted Options (ex at 5c expire 05-Dec 2019)	15M
Share Price (25-Jun-2018)	AUD 0.021
Market Capitalisation (undiluted)	AUD 20M
Shareholders	1,653
Cash (projected as at 30-Jun-2018)	AUD 8.5M

% holding Substantial Shareholders	
Richard Keevers (Chairman)	6.46%
Management (Including Mr Keevers)	17.24%

Board of Directors	
Non-Executive Chairman	Richard Keevers
Managing Director	David Christensen
Executive Director	Geoffrey McConachy
Non Executive Director	Stephen Bizzell
Non Executive Director	Chris Anderson

Siviour Project Summary

Large Resource

One of the world's largest resources with a Current JORC Resource of **80.6 Mt @ 7.9% TGC for 6.4 Mt** of contained Graphite. Siviour is open along strike with ample scope to expand.

Low Opex

Siviour's flat lying orientation underpins a low cost of production. Estimated OPEX of US\$ 333/t.

High Quality Graphite Product

Siviour has a favourable flake size distribution and easily upgrades to high purity for lithium-ion battery and other high growth markets.

The Best Location

- Located in Australia, one of the world's most stable jurisdictions.
- Close to port and highways.
- Grid power and experienced local workforce. Local government a strong supporter of mining.

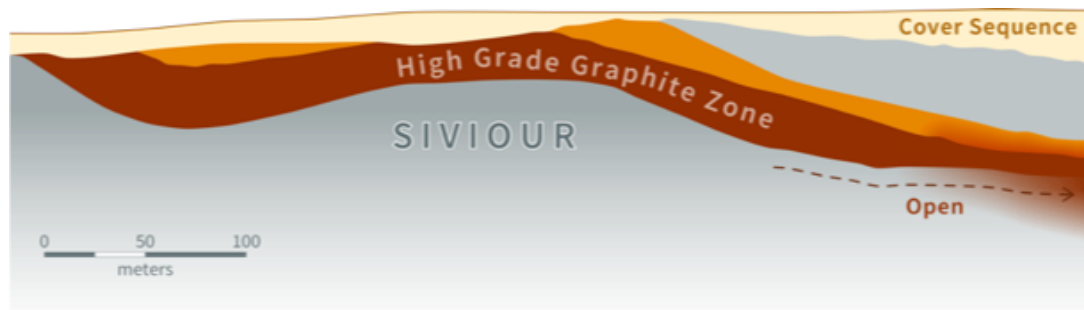

***"Siviour is unique
as a Tier-1 graphite
development in
Australia"***

Resource Summary

Siviour is one massive ore body, offering consistent supply of high-quality graphite.

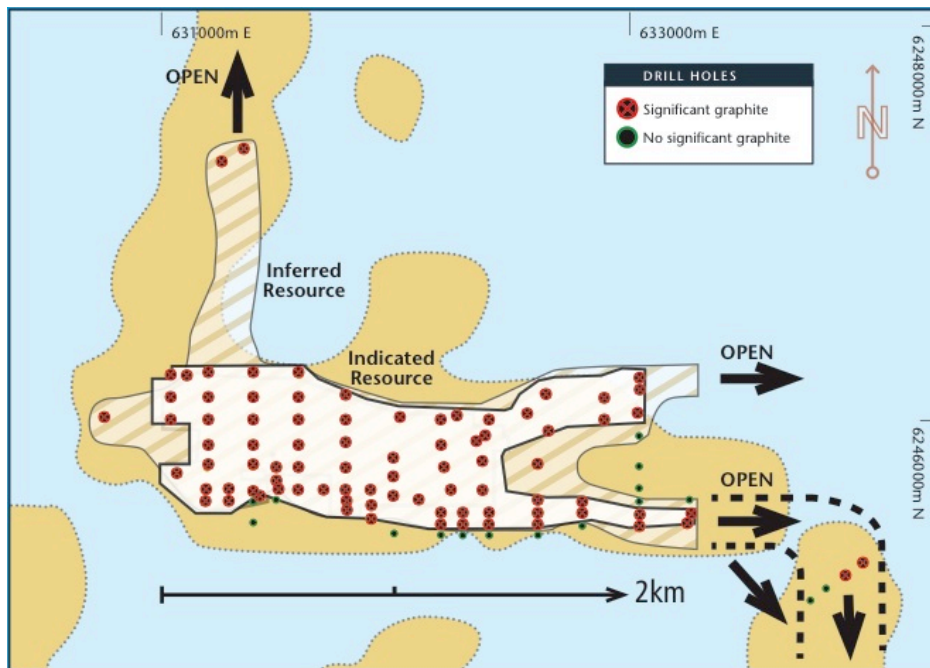

Resource category	Mineralisation (Mt)	TGC	Contained graphite (Mt)
Indicated	51.8	8.1%	4.2
Inferred	21.8	7.6%	2.2
Total	80.6	7.9%	6.4

Reserve category	Ore (Mt)	TGC	Contained graphite (Mt)
Proven	--	--	--
Probable	45.2	7.9%	3.6
Total	45.2	7.9%	3.6

Development Summary

Siviour can be developed sooner by a two-staged development.

Stage 1 uses mains water and diesel power offering outstandingly low CAPEX. This stage allows Renascor to target initial off-take agreements while providing bulk samples of Siviour graphite. Importantly, Stage 1 also provides cash flow and establishment as a graphite producer.

Larger users of graphite generally require bulk samples for testing of consistency. The supply of these bulk samples to technical and off-take partners will greatly assist in Stage 2 development. Between Stages 1 and 2, Renascor will also work with product development targeted at particular niche markets for expansion.



Metallurgy

Metallurgical testing has established ability to produce high quality graphite products at low OPEX using conventional (non-chemical, non-thermal) flowsheet.

Flake Category	Particle Size		Percentage	Annual Production
	Microns (µm)	Mesh		
Jumbo	>300	+48	6%	8,520t
Large	180 to 300	-48 to +80	20%	28,400t
Medium	150 to 180	-80 to +100	10%	14,200t
Small	75 to 150	-100 to +200	43%	61,060t
Fine	<75	-200	21%	29,820t

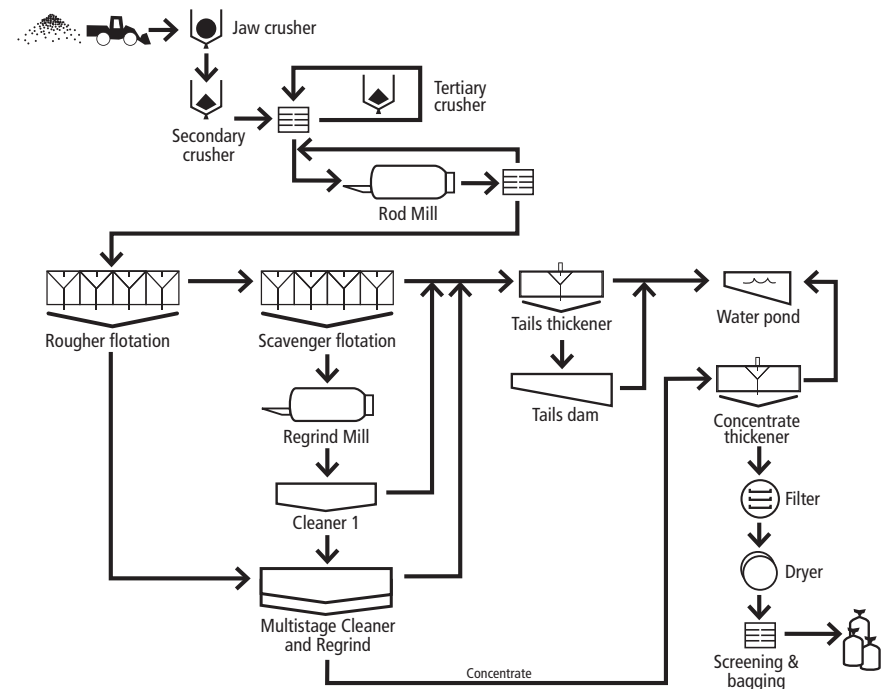

Metallurgy

Sivour offers the potential to produce low-cost, globally competitive concentrates within mining friendly Australia.

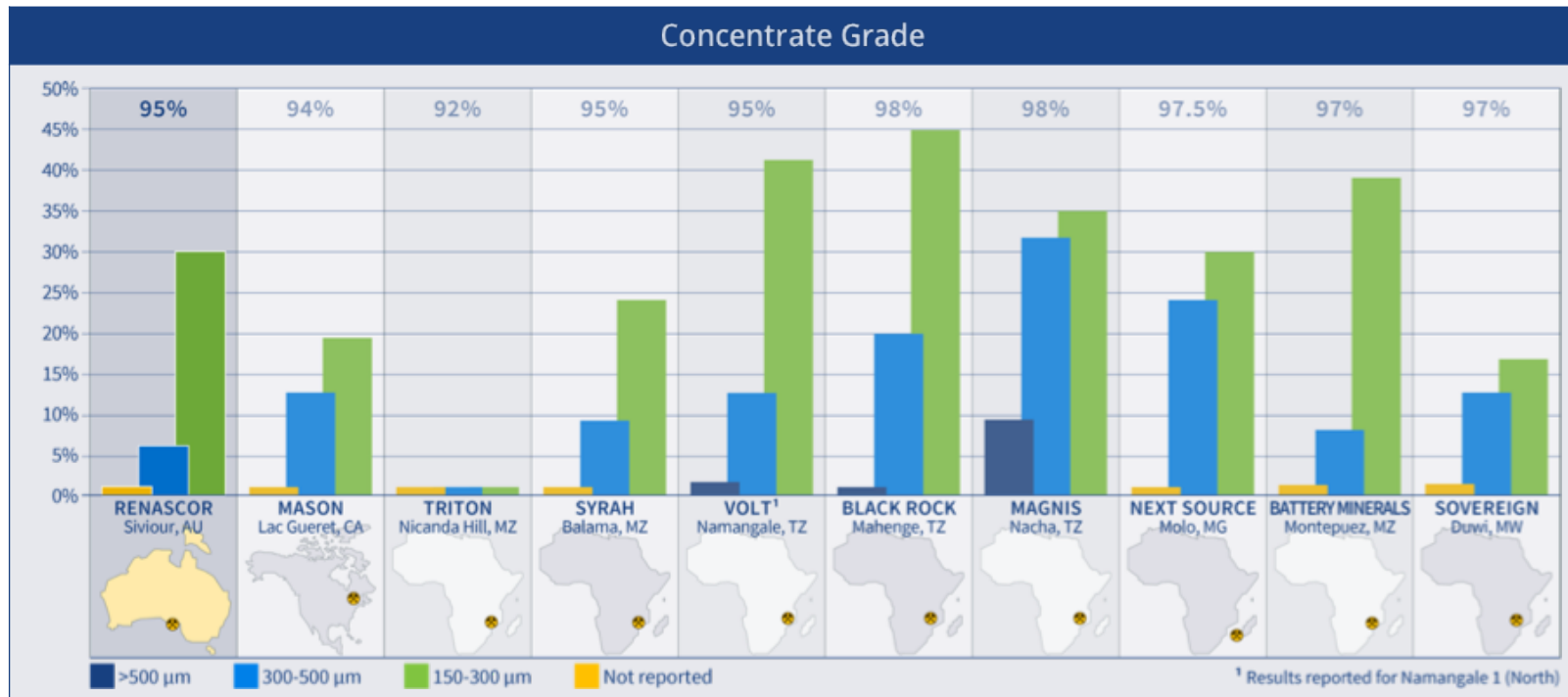

Spherical Graphite

Independent tests confirm Siviour concentrates can be processed into up to 99.99% spherical graphite suitable for use in Lithium-ion battery anodes.

Parameter	Test 1	Test 2
Fixed Carbon	99.97%	99.99%
Ash content	0.03%	0.02%
D10 Size Fraction (-10% finer than this size)	9.8 µm	11.3 µm
D50 Size Fraction (-50% finer than this size)	16.3 µm	18.4 µm
D90 Size Fraction (-90% finer than this size)	27.5 µm	29.7 µm
Ratio D10 to D90 sizes	2.8	2.8
Tap Density (measure of density of spherical graphite powder settled in test cylinder)	0.93 g/cm ³	0.95 g/cm ³

Expandable Graphite

Independent tests confirm Siviour concentrates are suitable for expandable graphite in excess of the typical industry expansion coefficient requirements.

Expansion Coefficient for Siviour Graphite Concentrations			
Parameter	Siviour Samples		Industry Standard
	+50 mesh (>300 µm)	+80 mesh (>180 µm)	
Expansion Coefficient (ml/g)	320	275	230

Both samples were tested for expansion using sulfuric acid based interaction agents and by heating to 1,000°C.

Both samples of Siviour graphite concentrates expanded at rates in excess of the typical industry standard for high-quality expandable graphite created from Chinese flake graphite concentrates

Expandable graphite is created by heating graphite to a temperature that causes exfoliation (expansion) of individual flakes of graphite.

Expandable graphite is increasingly sought-after for several applications including flame retardant building materials and textiles.

Graphite concentrates that expand at high rates selling at a significant premium to typical graphite concentrates.

Low Cost with Safe Supply

Lowest quartile operating costs globally in mining friendly Australia.

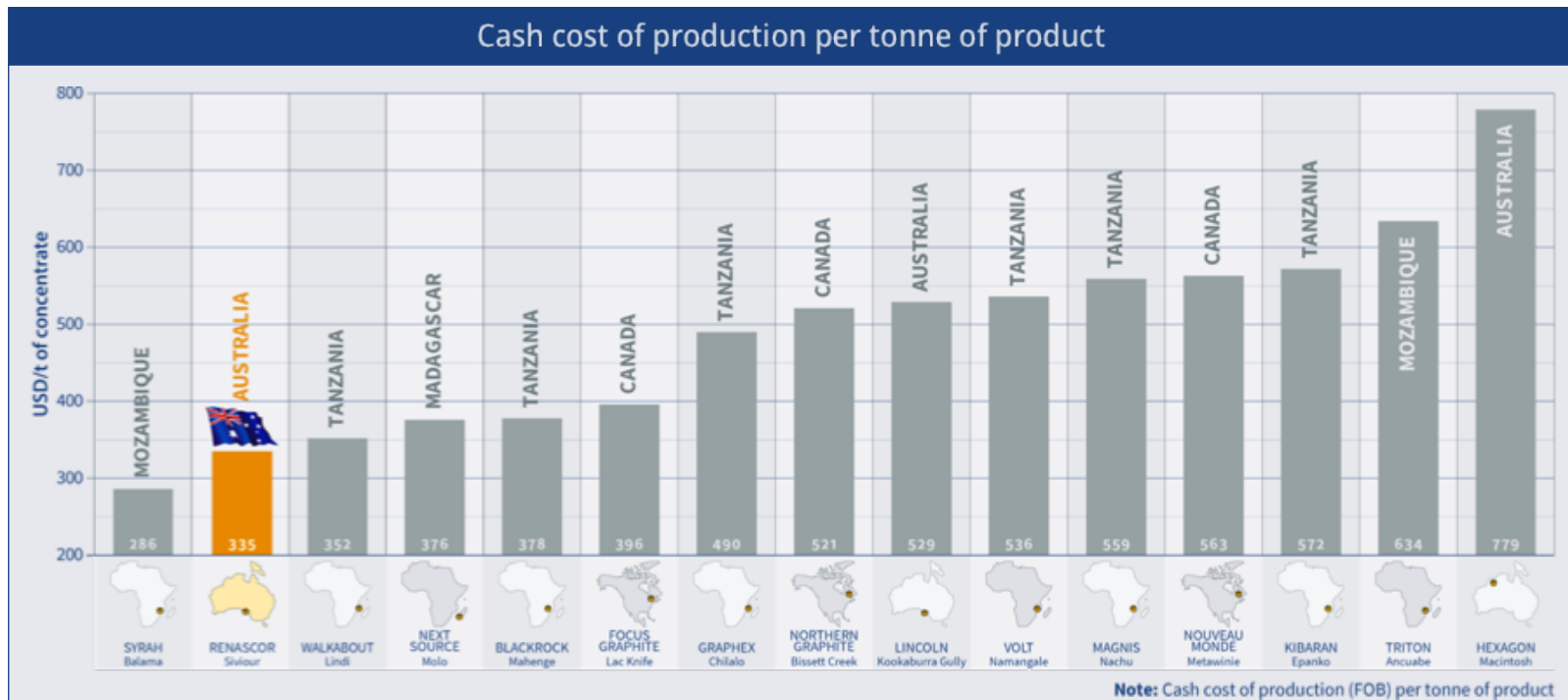

Mine to Market

- Simple, safe and reliable transport from our Australian graphite resource.
- Road transport from Arno Bay to Port Adelaide.
- Initial mining planned for Q4, 2019, with production in Q1 2020.
- Possibility to further process in-country and value add to spherical grade and/or expandable graphite.

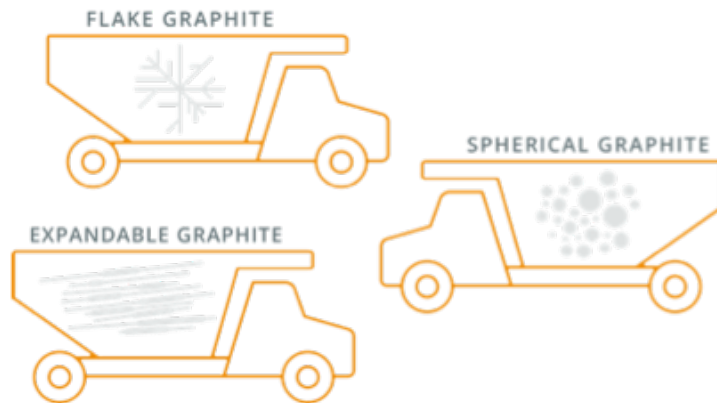

Siviour Timelines

- Project Feasibility Study (PFS) and Spherical Scoping Study complete.
- Definitive Feasibility Study (DFS) and Spherical PFS underway.
- Mine lease expected by Q1, 2019.
- Mine Construction planned for Q3 and Q4 , 2019.
- First mining planned for Q4, 2019, with first production in Q1 2020.

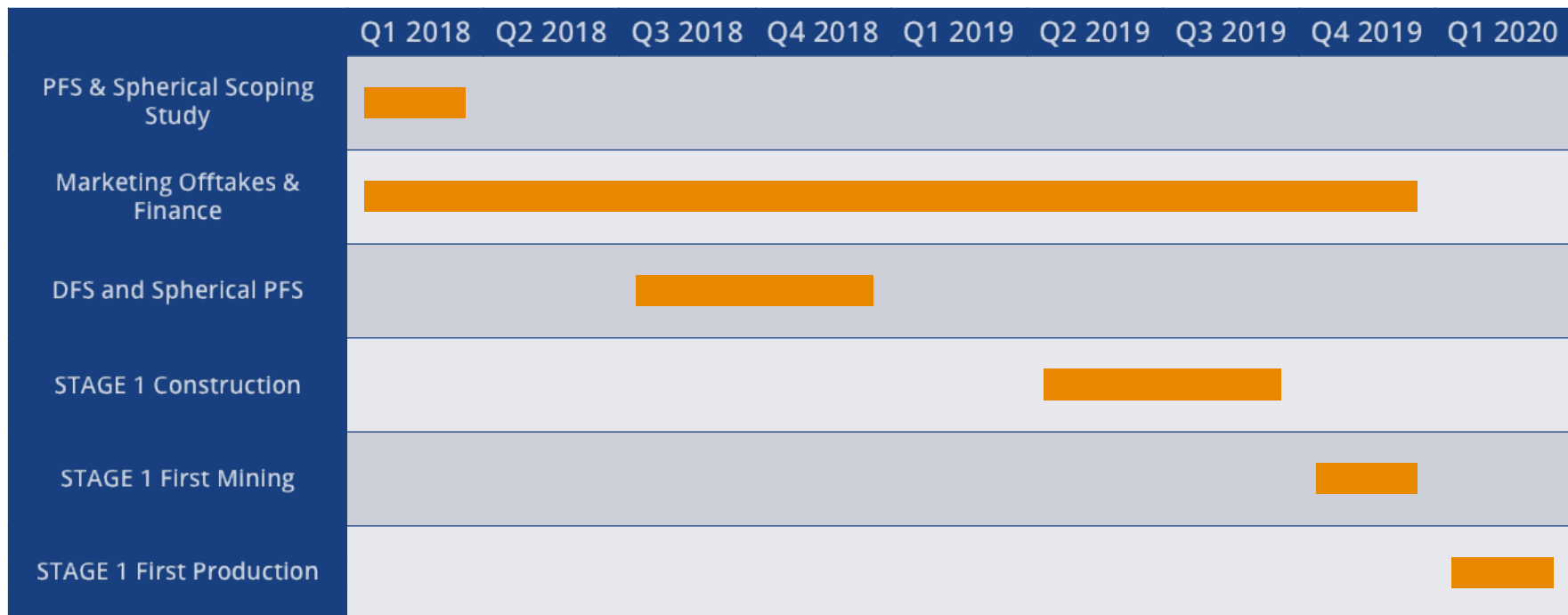

Project Portfolio

Renascor’s project portfolio includes pipeline of cobalt prospects in emerging South Australian cobalt districts.



Farina Project



Olary Project

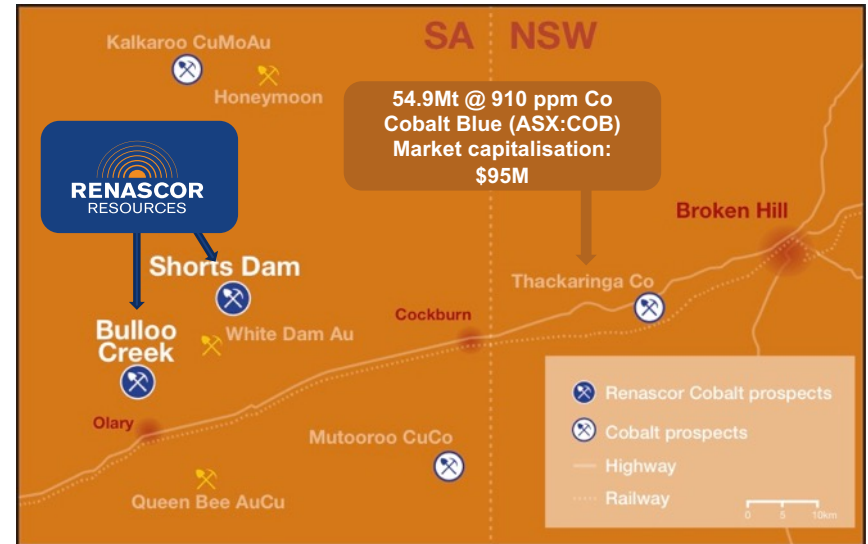

Farina Project

Drill-ready Zambian Copperbelt-style copper-cobalt targets.

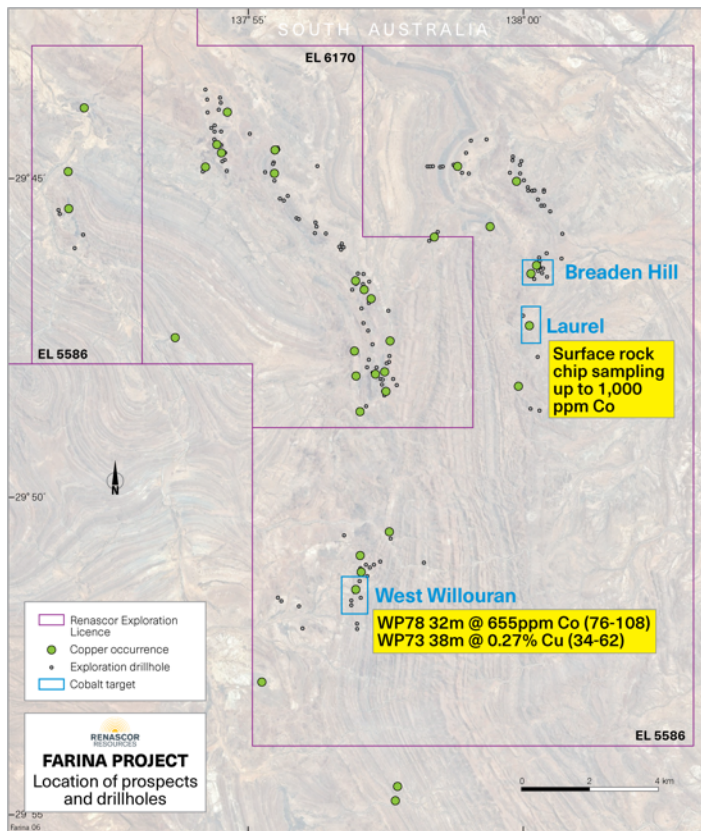

Olary Project

Prospects include ore grade cobalt drill intersections proximate to Cobalt Blue's (ASX: COB) Thackaringa Cobalt Project.



Shorts Dam

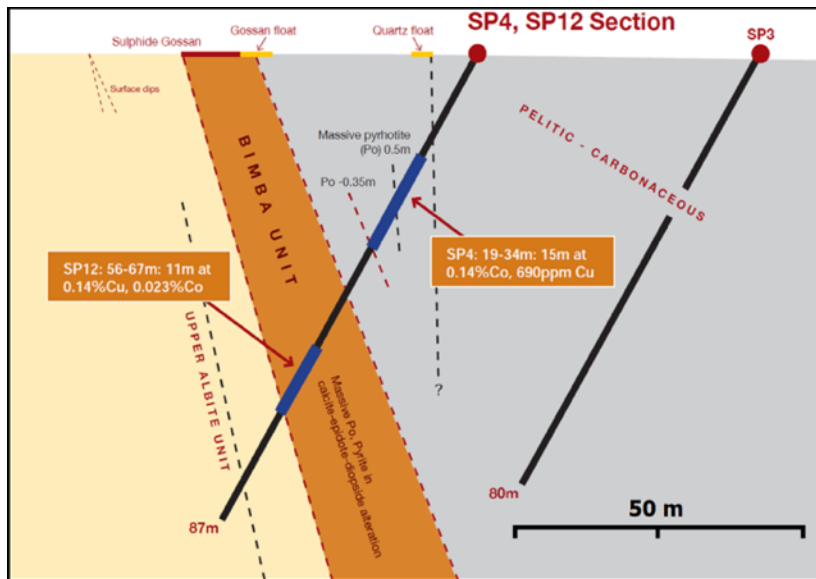

Buloo Creek

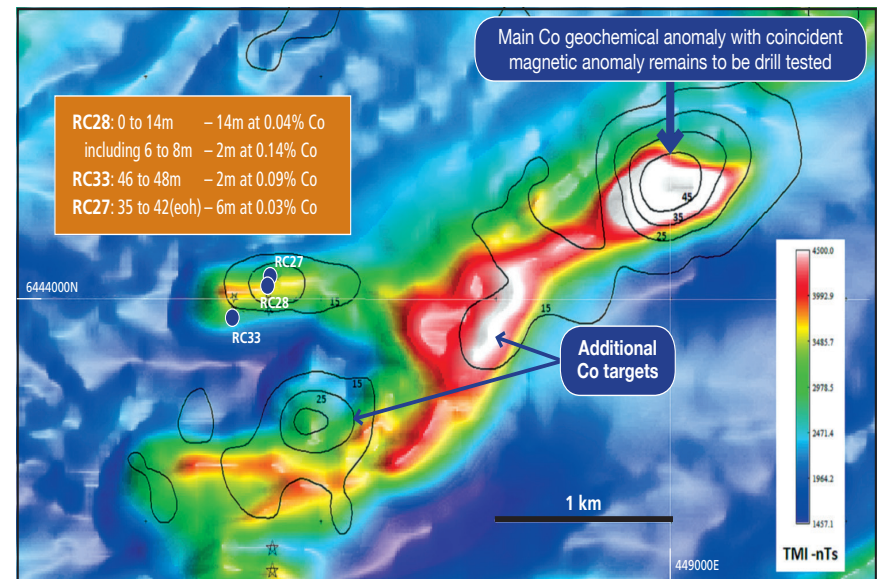

Re-rating Potential

Renascor has quickly advanced the development of Siviour since its discovery in 2016 and has potential to continue to climb the value curve.

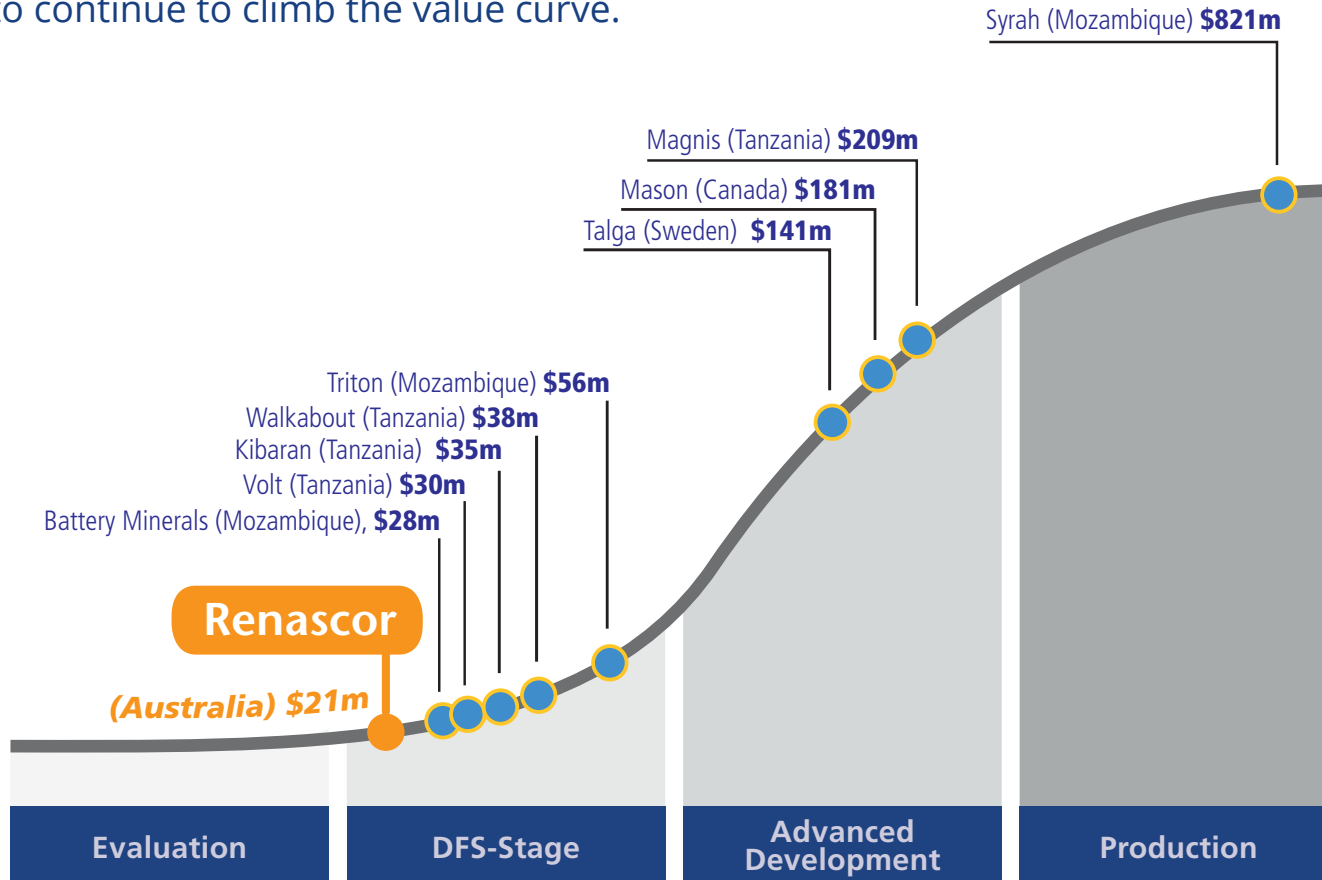

Near-term Value Drivers

Renascor is fully-funded to Decision to Mine. Strong upcoming news flow expected to include:

- **Offtake.** With completion of PFS and dispatch of customer samples, potential for additional offtake developments in 2018.
- **Acquisition of 100%-ownership in Siviour Project.** Subject to shareholder approval, Renascor will acquire 100% of Siviour Project. Shareholder meeting planned for next quarter.
- **Project improvements.** Upcoming metallurgical and technological programs and reserve-definition drilling offer potential to improve PFS project economics.
- **Spherical graphite.** Completion of Spherical PFS (expected next quarter) offers potential for improved project economics and more direct involvement in lithium-ion battery supply chain.
- **Project finance and DFS.** As the Siviour DFS advances towards completion (expected in Q1 2019), focus will turn to project finance for stage one construction.
- **Cobalt drilling.** Drill testing of Farina and Olary cobalt targets expected in Q3 and Q4.

Summary

Siviour is a Tier-1 graphite project

One massive ore body offers consistent high-quality supply

Fully-funded to Decision to Mine

Globally competitive: Low OPEX and CAPEX

Mining-friendly Australia

Near-term value drivers



Forward Looking Statements

This Presentation may include statements that could be deemed "forward-looking" statements. Although Renascor Resources Limited (the "Company") believes the expectations expressed in such forward-looking statements are based on reasonable assumptions, such statements are not guarantees of future performance and actual results or developments may differ materially from those expected in the forward-looking statements or may not take place at all.

No Offer to Sell or Invitation to Buy

This Presentation is not, and should not be considered to, constitute any offer to sell, or solicitation of an offer to buy, any securities in the Company, and no part of this Presentation forms the basis of any contract or commitment whatsoever with any person. The Company does not accept any liability to any person in relation to the distribution or possession of this Presentation from or in any jurisdiction.

Disclaimer

Whilst care has been exercised in preparing and presenting this Presentation, to the maximum extent permitted by law, the Company and its representatives make no representation, warranty or undertaking, express or implied, as to the adequacy, accuracy, completeness or reasonableness of this Presentation; accept no responsibility or liability as to the adequacy, accuracy, completeness or reasonableness of this Presentation; and accept no responsibility for any errors or omissions from this Presentation

Competent Persons Statement

The results reported herein, insofar as they relate to exploration activities and exploration results, are based on information provided to and reviewed by Mr G.W. McConachy (Fellow of the Australasian Institute of Mining and Metallurgy) who is a director of the Company. Mr McConachy has sufficient experience relevant to the style of mineralisation and type of deposits being considered to qualify as a Competent Person as defined by the 2012 Edition of the Australasian Code for Reporting of Exploration Results, Mineral Resources and Ore Reserves (the JORC Code, 2012 Edition). Mr McConachy consents to the inclusion in the report of the matters based on the reviewed information in the form and context in which it appears.

The results reported herein, insofar as they relate to metallurgical test work results, are based on information provided to and reviewed by Mr Simon Hall, a Competent Person who is a Member of the Australasian Institute of Mining and Metallurgy and a consultant to the Company. Mr Hall has sufficient experience relevant to the mineralogy and type of deposit under consideration and the typical beneficiation thereof. Mr Hall consents to the inclusion in the report of the matters based on the reviewed information in the form and context in which it appears.



David Christensen: Managing Director
Telephone: +61 (8) 8363 6989
Email: info@renascor.com.au
Website: renascor.com.au
Office Location: 36 North Terrace, Kent Town
South Australia 5067



Mastermines

Renascor Resources Limited | ASX:
RNU