

14 December 2017

Clean TeQ to Commence Trading on Toronto Stock Exchange

Mr Robert Friedland and Mr Jiang Zhaobai, Co-Chairmen of Clean TeQ Holdings Limited (**Clean TeQ** or **Company**) (CLQ:ASX/TSX; CTEQF:OTCQX), and Mr Sam Riggall, Chief Executive Officer of the Company, today announced that the Company's application for a secondary listing on the Toronto Stock Exchange (**TSX**) has been approved by the TSX. Trading of the Company's ordinary shares on the TSX is expected to commence at the open of trading in Toronto, Canada on Friday 15th December 2017 under the stock symbol "CLQ".

Co-Chairman Mr Robert Friedland commented, *"We are delighted to be listing on the Toronto Stock Exchange and believe it represents a significant milestone for the business as we develop the globally significant Clean TeQ Sunrise Project. The additional listing will deliver improved accessibility and liquidity for a broad range of retail and institutional investors in Canada and the United States."*

The Company's ordinary shares will continue to trade under the symbol "CLQ" on the Australian Securities Exchange and "CTEQF" on the United States OTCQX Exchange. The ordinary shares will be fully transferrable between the Australian and Canadian share registries. Please contact Computershare Investor Services (www.computershare.com) for more information.

The ISIN for the ordinary shares is AU 000000CLQ2 and the CUSIP is Q2509V105.

The attached Annual Information Form for the year ended 30 June 2017 is a Canadian disclosure requirement and has been prepared as part of the listing on TSX.

For more information about Clean TeQ please contact:

Richard Glass, Investor Relations (Australia)	+61 3 9797 6781
Evan Young, Investor Relations (North America)	+1 647 808 2141

About Clean TeQ Holdings Limited (ASX/TSX: CLQ) – Based in Melbourne, Australia, Clean TeQ is a leader in metals recovery and industrial water treatment through the use of its proprietary Clean-iX® continuous ion exchange technology.

For more information about Clean TeQ please visit the Company's website www.cleanteq.com.

About the Clean TeQ Sunrise Project – Clean TeQ is the 100% owner of the Clean TeQ Sunrise Project, located in New South Wales, Australia. The Clean TeQ Sunrise Project is one of the largest cobalt and nickel deposits outside of Africa, and one of the largest and highest-grade accumulations of scandium ever discovered.

About Clean TeQ Water – Through its wholly owned subsidiary Clean TeQ Water, Clean TeQ is also providing innovative wastewater treatment solutions for removing hardness, desalination, nutrient removal, zero liquid discharge. The sectors of focus include municipal wastewater, surface water, industrial waste water and mining waste water. For more information about Clean TeQ Water please visit www.cleanteqwater.com

This release may contain forward-looking statements. The actual results could differ materially from a conclusion, forecast or projection in the forward-looking information. Certain material factors or assumptions were applied in drawing a conclusion or making a forecast or projection as reflected in the forward-looking information.

CLEAN TEQ HOLDINGS LIMITED



Annual Information Form

For the year ended June 30, 2017

November 30, 2017

TABLE OF CONTENTS

FORWARD LOOKING STATEMENTS	1
DEFINITIONS AND OTHER INFORMATION	3
CURRENCY AND EXCHANGE RATE DATA	3
DEFINITIONS.....	3
SCIENTIFIC AND TECHNICAL INFORMATION	3
DESIGNATED FOREIGN ISSUER STATUS	3
CORPORATE STRUCTURE OF THE COMPANY	4
NAME, ADDRESS AND INCORPORATION.....	4
INTERCORPORATE RELATIONSHIPS.....	4
GENERAL DEVELOPMENT OF THE BUSINESS	5
OVERVIEW.....	5
THREE YEAR HISTORY	5
DESCRIPTION OF THE BUSINESS	7
OVERVIEW.....	7
CLEAN TEQ SUNRISE PROJECT	9
INTRODUCTION.....	9
PROJECT OVERVIEW.....	9
MINERAL RESOURCES AND MINERAL RESERVES	12
GEOLOGICAL SETTING, MINERALIZATION, DEPOSIT TYPES AND DRILLING	16
SAMPLING, ANALYSIS AND DATA VERIFICATION	17
SECURITY OF SAMPLES	18
MINING, PROCESSING AND RECOVERY OPERATIONS	18
INFRASTRUCTURE, PERMITTING AND COMPLIANCE ACTIVITIES.....	24
ENVIRONMENT, PERMITTING, SOCIAL AND COMMUNITY.....	26
CAPITAL AND OPERATING COSTS	29
RISK FACTORS	32
DIVIDENDS AND DISTRIBUTIONS	42
DESCRIPTION OF CAPITAL STOCK	42
ORDINARY SHARES	42
SHAREHOLDER APPROVAL.....	43
MARKET FOR SECURITIES	43
MARKET	43
TRADING PRICE AND VOLUME OF THE ORDINARY SHARES	43
PRIOR SALES	44
ESCROWED SECURITIES AND SECURITIES SUBJECT TO CONTRACTUAL RESTRICTION ON TRANSFER	44
DIRECTORS AND EXECUTIVE OFFICERS	44
CEASE TRADE ORDERS, BANKRUPTCIES AND PENALTIES AND SANCTIONS	46
CONFLICTS OF INTEREST.....	47
EMPLOYEE INCENTIVE PLAN	47

LEGAL PROCEEDINGS AND REGULATORY ACTIONS	49
AUDIT COMMITTEE INFORMATION	49
INTERESTS OF MANAGEMENT AND OTHERS IN MATERIAL TRANSACTIONS	50
TRANSFER AGENTS AND REGISTRARS	50
MATERIAL CONTRACTS	50
INTERESTS OF EXPERTS	50
NAMES OF EXPERTS	50
INTERESTS OF EXPERTS.....	50
ADDITIONAL INFORMATION.....	51
SCHEDULE “A”.....	1
INTERPRETATION.....	1
SCHEDULE “B”.....	4

FORWARD LOOKING STATEMENTS

Certain statements in this annual information form (“**AIF**”) constitute “forward-looking statements” or “forward-looking information” within the meaning of applicable securities laws. Such statements involve known and unknown risks, uncertainties and other factors which may cause the actual results, performance or achievements of Clean TeQ Holdings Limited (“**Clean TeQ**” or the “**Company**”), or its mineral projects, or industry results, to be materially different from any future results, expectations, performance or achievements expressed or implied by such forward-looking statements or forward-looking information. Such statements can be identified by the use of words such as “may”, “would”, “could”, “will”, “intend”, “expect”, “believe”, “plan”, “anticipate”, “estimate”, “scheduled”, “forecast”, “predict” and other similar terminology, or state that certain actions, events or results “may”, “could”, “would”, “might” or “will” be taken, occur or be achieved. These statements reflect the Company’s current expectations regarding future events, performance and results and speak only as of the date of this AIF.

Specific statements in this AIF that constitute forward-looking statements or forward-looking information include, but are not limited to, statements regarding: the planned amount and timing, as well as the degree of success of, any future exploration program including drilling programs, the potential addition of mineral resources and the potential to upgrade exploration targets to mineral resources as a result of such exploration and drilling programs; the prospective receipt of permits, licences or approvals at any mineral project, including those necessary to commence development or mining operations; future extraction, methodologies and the exploitation of mineral deposits; capital expenditure requirements; expected production capacity; certain mining assumptions; cost estimates; product market assumptions; market price assumptions; transportation and marketing costs; Life of Mine (“**LoM**”) production parameters; estimation of mineral reserves and mineral resources; the Company spending the funds available to it as stated in this AIF; the ability to pay dividends in the future; expectations regarding the Company’s ability to subsequently raise capital; expenditures to be made by the Company to meet certain work commitments; work plans to be conducted by the Company; reclamation and rehabilitation obligations and liabilities; treatment under governmental regulatory regimes with respect to environmental matters; treatment under governmental taxation regimes; government regulation of mining operations; dependence on personnel; and competitive conditions.

Forward looking statements are based on the reasonable assumptions, estimates, analysis and opinions of management made in light of its experience and its perception of trends, current conditions and expected developments, as well as other factors that management believes to be relevant and reasonable in the circumstances at the date that such statements are made, but which may prove to be incorrect. Management believes that the assumptions and expectations reflected in such forward looking statements are reasonable. Assumptions have been made regarding, among other things: the accuracy of the estimation of mineral resources and mineral reserves; that exploration activities and studies will provide results that support anticipated development and extraction activities; that studies of estimated mine life and production rates at the Clean TeQ Sunrise Project will provide results that support anticipated development and extraction activities; that the Company will be able to obtain additional financing on satisfactory terms, including financing necessary to advance the development of the Clean TeQ Sunrise Project; that infrastructure anticipated to be developed or operated by third parties, including electrical generation and transmission capacity, will be developed and/or operated as currently anticipated; that laws, rules and regulations are fairly and impartially observed and enforced; that the Company will be able to obtain, maintain, renew or extend required permits; the Company executing its mine development plans in accordance with its budgets and planning; feasibility and other studies supporting the Company’s development plans; applicable environmental and other laws and other regulations not being amended; key management continuing to serve in their respective roles with the Company; title to properties and mineral licenses not being challenged; and no adverse changes occurring to the prices of scandium, nickel

and cobalt that might adversely affect the prospects for operating and further developing the Clean TeQ Sunrise Project or which might make it uneconomic to proceed with further development. All other assumptions used in this AIF constitute forward-looking information.

This AIF also contains references to estimates of mineral resources and mineral reserves. The estimation of mineral resources is inherently uncertain and involves subjective judgments about many relevant factors. Mineral resources that are not mineral reserves do not have demonstrated economic viability. Mineral reserves that have demonstrated economic viability may cease to be economically viable as a result of many factors, including those set forth in the AIF. The accuracy of any such estimates of mineral resources and mineral reserves is a function of the quantity and quality of available data, and of the assumptions made and judgments used in engineering and geological interpretation (including estimated future production from the Clean TeQ Sunrise Project, the anticipated tonnages and grades that will be mined and the estimated level of recovery that will be realized), which may prove to be unreliable and depend, to a certain extent, upon the analysis of drilling results and statistical inferences that may ultimately prove to be inaccurate. Mineral resource estimates may have to be re-estimated based on, among other things: fluctuations in nickel sulphate, cobalt sulphate, scandium or other mineral prices; results of drilling; results of metallurgical testing and other studies; proposed mining operations, including dilution; the evaluation of mine plans subsequent to the date of any estimates; or the possible failure to receive required permits, approvals and licences. Mineral reserves may have to be re-estimated based on, among other things: fluctuations in nickel sulphate, cobalt sulphate, scandium or other mineral prices; results of actual mining operations; changes to mine plans subsequent to the date of any estimates; or the possible failure to receive required permits, approvals and licences, or the failure to have such required permits, approvals, or licences honored or extended.

Forward-looking statements involve significant risks and uncertainties, should not be read as guarantees of future performance or results, and will not necessarily be accurate indicators of whether or not such results will be achieved. A number of factors could cause actual results to differ materially from the results discussed in the forward-looking statements, including, but not limited to, the factors discussed above and those listed under the heading “*Risk Factors*”, as well as unexpected changes in laws, rules or regulations, or their enforcement by applicable authorities, including potentially arbitrary action; the failure of parties to contracts with the Company to perform as agreed; social or labour unrest; changes in commodity prices; unexpected changes in the cost of mining consumables; and the failure of exploration programs or current or future economic studies to deliver anticipated results or results that would justify and support continued exploration, studies, development or operations.

Although the forward-looking statements contained in this AIF are based upon what management of the Company believes are reasonable assumptions, the Company cannot assure readers that actual results will be consistent with these forward-looking statements. The Company’s actual results could differ materially from those anticipated in these forward-looking statements, as a result of, amongst others, those factors noted above and those listed under the heading “*Risk Factors*”. These forward-looking statements are made as of the date of this AIF and are expressly qualified in their entirety by this cautionary statement. Subject to applicable securities laws, the Company assumes no obligation to update or revise the forward-looking statements contained herein to reflect events or circumstances occurring after the date of this AIF.

DEFINITIONS AND OTHER INFORMATION

Currency and Exchange Rate Data

Unless otherwise indicated, all references to “C\$” in this AIF are to Canadian dollars, all references to “A\$” are to Australian dollars, and all references to “US\$” are to U.S. dollars. On November 30, 2017, the daily rate of exchange (16:30 ET) of the Bank of Canada was US\$1.00 = C\$1.2888 and A\$1.00 = C\$0.9757.

Definitions

Attached at Schedule “A” to this AIF are tables setting out defined terms and a *Glossary of Mining Terms and Abbreviations*.

Scientific and Technical Information

The scientific and technical information with respect to the Clean TeQ Sunrise Project contained in this AIF is derived from the Syerston Nickel Cobalt Project, New South Wales, Australia NI 43-101 Technical Report dated October 30, 2017 with an effective date of October 30, 2017 (the “**Technical Report**”). Prior to November 2, 2017, the Clean TeQ Sunrise Project was named the “Syerston Project”.

The technical information in this AIF has been updated with current information where applicable. The full text of the Technical Report has been filed with Canadian securities regulatory authorities pursuant to NI 43-101 and is available for review under the Company’s SEDAR profile at www.sedar.com. For definitions of certain technical terms used in this AIF, see “*Glossary of Mining Terms and Abbreviations*” in Schedule A.

Peter Fairfield of SRK Consulting (Australasia) Pty Ltd. (“**SRK**”) has reviewed and approved the scientific and technical information in respect of the Clean TeQ Sunrise Project contained in this AIF. Mr. Fairfield is considered, by virtue of his education, experience and professional association, to be a qualified person for the purposes of NI 43-101. Mr. Fairfield is independent within the meaning of NI 43-101.

DESIGNATED FOREIGN ISSUER STATUS

Clean TeQ listed on the TSX on December 15, 2017. Upon that listing, Clean TeQ became a reporting issuer in the province of Ontario. However, in accordance with National Instrument 71-102 – *Continuous Disclosure and Other Exemptions Relating to Foreign Issuers* (“**NI 71-102**”), Clean TeQ will be a “designated foreign issuer” (as defined in NI 71-102) for the balance of the current financial year and until such time as it ceases to satisfy the requirements to be a designated foreign issuer. As such, Clean TeQ will not be subject to the same ongoing reporting requirements as most other reporting issuers in Canada. Generally, Clean TeQ will comply with Canadian ongoing reporting requirements if it complies with the regulatory requirements of the ASX, which is a “foreign regulatory authority” (as defined in NI 71-102) and files any documents required to be filed with or furnished to the ASX on SEDAR.

CORPORATE STRUCTURE OF THE COMPANY

Name, Address and Incorporation

Clean TeQ is an Australian based business focused on the development and commercialization of technologies for metals recovery and industrial water treatment. The Company was incorporated under the *Corporations Act 2001* (Australia) on September 10, 2007 in Victoria, Australia. The Company became a listed public company in Australia on November 5, 2007 and commenced trading on the ASX on November 9, 2007 under the trading symbol “CLQ”.

The Company’s head office and registered office is located at Unit 12, 21 Howleys Road, Notting Hill, Victoria, Australia 3168.

The Company’s fiscal year end is June 30.

Intercorporate Relationships

References in this AIF to the business of the Company include the business conducted by its material subsidiaries and material joint ventures. The following chart indicates the corporate structure of the Company and its subsidiaries, and the jurisdiction of incorporation of each. Ownership below is 100%, unless otherwise indicated.

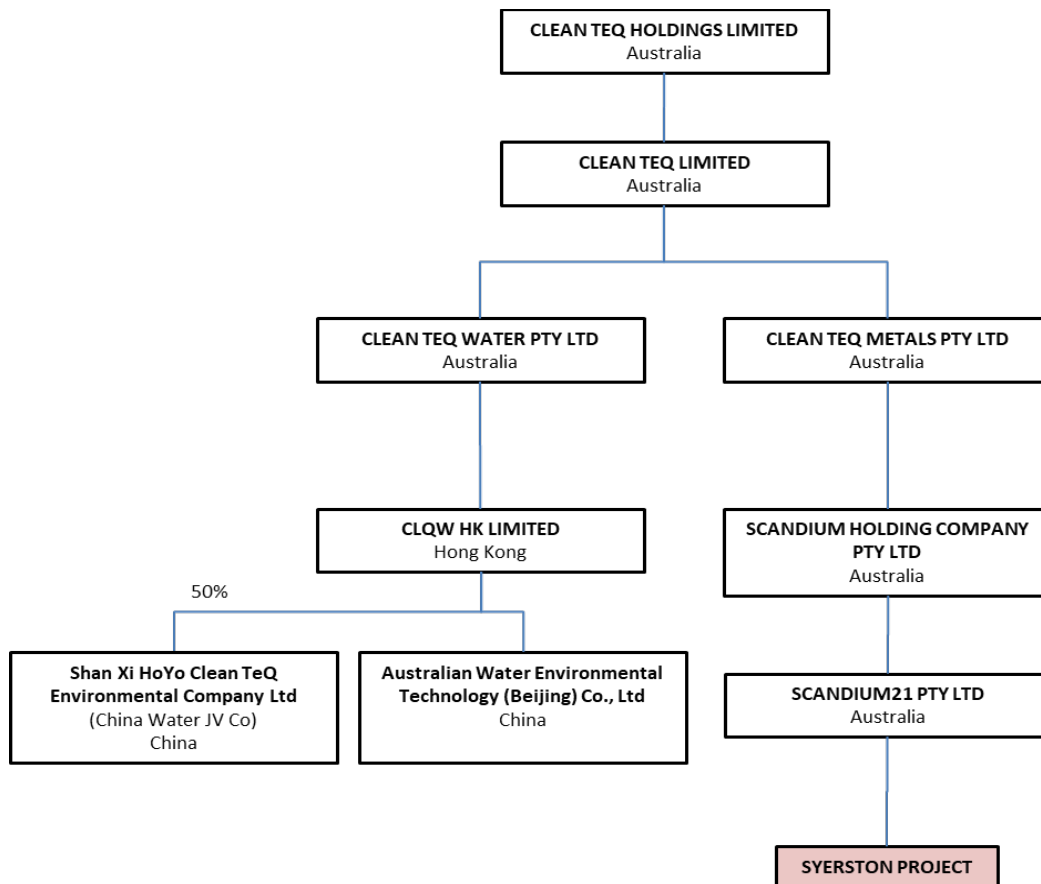

GENERAL DEVELOPMENT OF THE BUSINESS

Overview

Clean TeQ is an Australian based business focused on the development and commercialization of technologies for metals recovery and industrial water treatment. The Company's material property is the Clean TeQ Sunrise Project.

Three Year History

2015

In early 2015, following receipt of relevant ministerial and shareholder approvals, the Company completed the acquisition of 100% of the Clean TeQ Sunrise Project from the previous owner, Ivanplats Holding Company Pty Ltd. On January 23, 2015, the Company announced a maiden scandium mineral resource at the Clean TeQ Sunrise Project.

On March 10, 2015, the Company announced an agreement with Airbus APWorks GmbH, a subsidiary of the Airbus Group and the commercialization arm of Airbus Group technologies, which is focused on advance engineering and manufacturing processes. The agreement provided a framework for Clean TeQ and Airbus APWorks to work together in determining whether the Clean TeQ Sunrise Project could become a source of scandium metal for use in the next generation of light-weight high performance aluminum alloys.

On March 19, 2015, the Company announced an additional collaboration agreement with KBM Affilips B.V, a subsidiary of KBM Affilips Group, which manufactures master alloys at plants in The Netherlands and Belgium.

On May 25, 2015, the Company announced the results of a scoping study on the Clean TeQ Sunrise Project, focusing solely on the scandium resource. The results of this study were highly encouraging with a post-tax NPV of A\$279.1m and a post-tax IRR of 53% (based on long term scandium oxide prices of US\$1,500/kg).

On July 3, 2015, the Company announced the divestment of its 59% holding in Clean TeQ Aromatrix Pty Ltd for cash proceeds of A\$1,681,500.

In mid-July 2015, commissioning of the Clean-iX Resin-in-Pulp demonstration pilot plant commenced at ALS Metallurgy in Perth, Western Australia.

On August 24, 2015, Clean TeQ completed an entitlement offer under which 30,269,943 shares were issued to existing shareholders to raise A\$5.45 million. The shortfall of 6,606,631 shares (approximately A\$1.19 million) and an additional top-up placement of 12,362,164 new shares (approximately \$2.23 million) were allocated to nominees of the underwriter in Australia, BW Equities Pty Ltd.

During the fourth quarter of 2015, the Company made further progress at the Clean TeQ Sunrise Project with drilling activity confirming and extending the high-grade scandium zones. The results from this drilling program increased the confidence levels of the existing scandium resource at the Clean TeQ Sunrise Project as well as identifying a number of high grade extensions.

2016

In early 2016, Clean TeQ entered into an alliance with Universal Alloy Corporation and Deakin University's Institute for Frontier Metals to investigate the use of scandium in current and new aluminum alloys for lightweight aerospace components.

On January 20, 2016, the Company announced the first production of a 99.9% scandium oxide product from processing ore from the Clean TeQ Sunrise Project. This was the first time a significant quantity of

scandium oxide had been produced from primary ore from the Clean TeQ Sunrise Project and using Company's continuous ion exchange technology.

On March 17, 2016, the Company updated the scandium mineral resource.

During early May 2016, Clean TeQ completed a A\$4.0 million placement to institutional investors through the issue of 19,047,620 shares at an issue price of A\$0.21 per share.

On June 28, 2016, the Company announced the signing of a binding agreement with Jinzhong Hoyo Municipal Urban Investment & Construction Co. Ltd. ("**Hoyo**") to form a Chinese incorporated joint venture to pursue water treatment opportunities in China's Shanxi Province utilizing Clean TeQ's water purification technology.

In addition, Clean TeQ and Hoyo agreed to terms under which the new joint venture company would build, own and operate a Clean TeQ Continuous Ionic Filtration ("**CI**F") water treatment plant at an existing wastewater treatment facility owned and operated by Qixan in Shanxi Province. This agreement was subsequently executed on August 19, 2016.

In late August 2016, Clean TeQ updated its resource estimate for nickel and cobalt at the Clean TeQ Sunrise Project. See "Clean TeQ Sunrise Project" below.

In early October 2016, the Company announced completion of the PFS which demonstrated the potential for the Clean TeQ Sunrise Project to become a leading supplier of nickel and cobalt sulphate to the lithium-ion battery industry. The PFS assessed the economics of a 2.5Mtpa operation over an initial 20-year period with existing reserves available for up to 19 years of additional mine life and returned a post-tax NPV of US\$891 million and a 25% post-tax IRR (assuming long term average nickel and cobalt price forecasts of US\$7.50/lb and US\$12.00/lb respectively). See "Clean TeQ Sunrise Project" below.

On November 3, 2016, the Company announced a placement of 33,333,333 new shares at an issue price of A\$0.39 per share to Australian Super, to raise a total of A\$13.0 million. An additional 5,128,205 new shares were also issued at the same price to a number of existing institutional investors to raise another A\$2.0 million. Funds raised under this placement were required to fund completion of the bankable feasibility study for the Clean TeQ Sunrise Project.

On December 1, 2016, Clean TeQ entered an agreement with Airbus Group Innovations for the treatment and recycling of their proprietary Scalmalloy aluminum-magnesium-scandium powder used in additive manufacturing (3D printing) of aerospace components. Clean TeQ's processing system proposed for the Clean TeQ Sunrise Project can recover and recycle the highly valuable scandium metal from waste material produced during the production of highly advanced, light-weight products, thereby lowering the unit cost of the Scalmalloy product. Lowering the cost of Scalmalloy is important in securing wider adoption across the aerospace industry.

2017

On February 28, 2017, the Company announced a strategic partnership with leading Chinese conglomerate, Pengxin Mining involving an A\$81 million investment in Clean TeQ to fast track development of the Clean TeQ Sunrise Project. Pengxin Mining also agreed to assist Clean TeQ in securing Chinese project-debt finance for the Clean TeQ Sunrise Project. This placement was conducted at A\$0.88 per share, a 17% premium to the volume weighted average share price for the 20 days prior to the placement. Following the placement, Pengxin Group Chairman Mr. Jiang Zhaobai was appointed as Non-Executive Co-Chairman of Clean TeQ.

On May 23, 2017, the NSW Government Department of Planning and Environment approved Clean TeQ's application to modify the Development Consent for the Clean TeQ Sunrise Project. Approval of the modification allows the Company to include scandium oxide as a by-product of nickel and cobalt production.

On May 24, 2017, the Company announced its wholly-owned subsidiary, Clean TeQ Water Pty Ltd., had been awarded a significant contract by Multotec Process Equipment Pty Ltd. ("**Multotec**") to design,

procure and commission a Clean TeQ proprietary CIF wastewater treatment solution at a minerals processing plant currently being constructed in Oman. The CIF waste water treatment plant will treat waste water from a flue gas desulphurization scrubber to remove toxic pollutants, in particular sulphate, antimony and arsenic. In addition, the Company executed a technology distribution agreement for CIF with Multotec for the African region.

On June 15, 2017, the Company dispatched samples of high purity nickel sulphate to a number of potential customers in the lithium-ion battery supply chain for testing and analysis.

On July 25, 2017, Clean TeQ announced the acquisition of two autoclaves, critical components in the High Pressure Acid Leach (“**HPAL**”) circuit at the Clean TeQ Sunrise Project. The acquisition will enable an accelerated development schedule by reducing the substantial lead times required for this type of equipment.

On August 31, 2017, the Company announced a binding 5-year offtake agreement with Beijing Easpring. From the second year of Clean TeQ Sunrise Project production following ramp-up, the binding offtake contract is for fixed tonnages of 18,000 tonnes per annum nickel sulphate (approximately 4,000 tpa nickel metal equivalent) and 5,000 tonnes per annum cobalt sulphate (approximately 1,000 tpa cobalt metal equivalent) representing approximately 20% of forecast production based on the updated nickel and cobalt mineral resources completed in October 2017. Pricing of product sold under the offtake agreement is linked directly to the LME and LMB quoted metal pricing for nickel and cobalt respectively, with a sulphate premia to be agreed quarterly based on prevailing market prices. The agreement will convert to a life-of-mine offtake in the event that Beijing Easpring acquires a minimum 25% interest in the Clean TeQ Sunrise Project. See “Clean TeQ Sunrise Project” below.

DESCRIPTION OF THE BUSINESS

Overview

Clean TeQ is primarily focused on the development of its 100% owned Clean TeQ Sunrise Project, one of the world’s largest and highest grade nickel and cobalt deposits outside of Africa, as well as one of the largest and highest grade scandium projects globally.

Clean TeQ’s development strategy for the Clean TeQ Sunrise Project involves the application of its patented ion exchange processing technology, which will enable low cost production of high value products nickel sulphate and cobalt sulphate, which are critical raw material inputs into the rapidly expanding lithium-ion battery market.

The Company has rapidly progressed the Clean TeQ Sunrise Project through the completion of a Pre-Feasibility study in October 2016 entitled “Syerston Mine Pre-Feasibility Study, Nickel & Cobalt” (the “**PFS**”) and large scale pilot plant testwork which has confirmed the technical merits of our innovative process flowsheet design. The Clean TeQ Sunrise Project is development-ready with all permitting and development consents secured, supporting infrastructure in place including power, gas, water, rail and road access, and a preliminary offtake agreement secured for initial production.

A Definitive Feasibility Study (the “**DFS**”) is currently being completed for the Clean TeQ Sunrise Project and is expected to be completed during early 2018, before progressing through project financing, further offtake agreements and final investment decision during 2018.

Clean TeQ also operates a division focused on delivering waste water treatment solutions using its CIF technology. Key applications of the technology include the treatment of waste water produced from mining, oil and gas, municipal and industrial sources including process water, tailings, produced water and treated effluent.

The water division currently has a joint venture with Hoyo pursuing water treatment opportunities in China’s Shanxi Province utilizing Clean TeQ’s water purification technology. Clean TeQ and Hoyo have

also agreed to terms under which the new joint venture company would build, own and operate a Clean TeQ CIF water treatment plant at an existing wastewater treatment facility owned and operated by Qixan Hoyo Waste Water Treatment Co. Ltd. (“**Qixan**”) in Shanxi Province.

In addition, Clean TeQ Water has a contract with Multotec to design, procure and commission a Clean TeQ proprietary CIF wastewater treatment solution at a minerals processing plant currently being constructed in Oman. The CIF waste water treatment plant will treat waste water from a flue gas desulphurization scrubber to remove toxic pollutants, in particular sulphate, antimony and arsenic. In addition, the Company executed a technology distribution agreement for CIF with Multotec for the African region.

SRK has prepared the Technical Report, which provides an analysis of mining and processing of ore through a high pressure acid leach/ resin-in-pulp process, to determine the economics of producing hydrated nickel sulphate (NiSO₄.6H₂O) and hydrated cobalt sulphate (CoSO₄.7H₂O). The Technical Report is based on the PFS. SRK has reviewed and validated the basis of and results contained in the PFS and supporting information and has made changes where appropriate.

The key parameters of the Clean TeQ Sunrise Project are tabled below.

Resource Base used for mine planning	2016 Measured & Indicated Resource - JORC Code (2012)
Autoclave Throughput	2.5 Mtpa
Average Strip Ratio	0.8:1
Autoclave Average Feed Grade (Years 3 -20)	
<i>Nickel</i>	0.80%
<i>Cobalt</i>	0.14%
Average Production (Years 3 - 10)	
<i>Nickel as Ni</i>	21,172 tpa
<i>Cobalt as Co</i>	3,919 tpa
Average Production (Years 3 - 20)	
<i>Nickel as Ni</i>	18,730 tpa
<i>Cobalt as Co</i>	3,222 tpa
Average Recoveries	
<i>Nickel</i>	93.5%
<i>Cobalt</i>	92.7%
Life of Mine	39 years
Life of Mine for Financial Modelling	20 years
Long-term Price Assumption	
<i>Nickel, based on NiSO₄.6H₂O Product</i>	US\$7.50/lb
<i>Cobalt, based on CoSO₄.7H₂O Product</i>	US\$14.00/lb
Foreign Exchange Rate	0.75US\$:1.00A\$
Total Capital Cost	
	A\$1,045M

	US\$784M
Average C1 Cash Cost (Year 3 - 20) ¹	
<i>without Co by-product credits</i>	US\$3.86/lb
<i>with Co by-product credits</i>	US\$1.40/lb
NPV – post tax	US\$747.5M
IRR – post tax ²	21.0%

Notes:

- 1 C1 cash cost does not consider any potential by-product revenue from scandium oxide sales, royalties, depreciation or sea freight of nickel and cobalt sulphate.
- 2 Post tax, 8% discount, 100% equity, real terms.

The large scale nickel and cobalt resource assessed through the PFS also hosts significant quantities of scandium. However, given the scandium market is still developing, the PFS base case assumes no scandium revenue. The potential to produce and market scandium as a by-product of nickel and cobalt sulphate production represents potential upside for the Clean TeQ Sunrise Project.

CLEAN TEQ SUNRISE PROJECT

Introduction

All disclosure in this section relating to the Clean TeQ Sunrise Project of a scientific or technical nature is based on, or derived from the Technical Report prepared by SRK. The following Qualified Persons prepared the Technical Report: Peter Fairfield, Peter Kitto, Lynn Widenbar, Simon Walsh and Danny Kentwell. The Technical Report is available for review at the Company’s profile on SEDAR at www.sedar.com.

The Technical Report is based on the PFS. Following completion of the PFS, Clean TeQ released mineral resource and mineral reserve estimates to the ASX under the guidelines of the JORC Code. The deposit at the Clean TeQ Sunrise Project is significantly developed – two feasibility studies for 2.0 Mtpa (2000) and 2.5 Mtpa (2005) (the “**2005 Study**”) nickel and cobalt operations were completed by the previous owners, Black Range Minerals (“**Black Range**”) and Ivanplats Syerston (“**Ivanplats**”). In addition to these historical studies, the environmental impact statement (“**EIS**”) completed in 2000 was referenced for potential environmental impacts and methodologies for mitigation of these impacts. An updated mineral resource estimate for 2017 (the “**2017 Resource Update**”) was produced by independent consultants Widenbar & Associates, and Development & Mining Services (Widenbar) in October 2017. The 2017 Resource Update was released to the ASX under the guidelines of the JORC Code.

Project Overview

Project location

The Clean TeQ Sunrise Project is situated in central New South Wales, about 350 km WNW of Sydney. The Clean TeQ Sunrise Project is well supported by major centres, with the mining communities of Parkes, Dubbo and Condobolin all located within 100 km of the Clean TeQ Sunrise Project area. The local town is Fifield which is located 4 km from the Clean TeQ Sunrise Project (Figure1-1). The Clean TeQ Sunrise Project area experiences a subtropical dry climate, i.e. very low rainfall, high daytime temperatures in summer and low minimum temperatures in winter.

The district is predominantly used for agriculture, with crops in the region including wheat, barley and oats. Sheep and cattle grazing is also common throughout the district. Due to widespread clearing for agriculture over the last 100 years, very little of the original vegetation remains.

Figure 1-1: Project location plan



The Clean TeQ Sunrise Project area is located on three pastoral properties and includes previously mined land (magnesite), State Forest and Crown Land. The Fifield State Forest occupies a small part of the Clean TeQ Sunrise Project area situated along the northern border, and the Unoccupied Crown Land is found in the north-eastern corner of the project area (Figure 1-2).

Figure 1-2: Layout or proposed infrastructure and State Forests

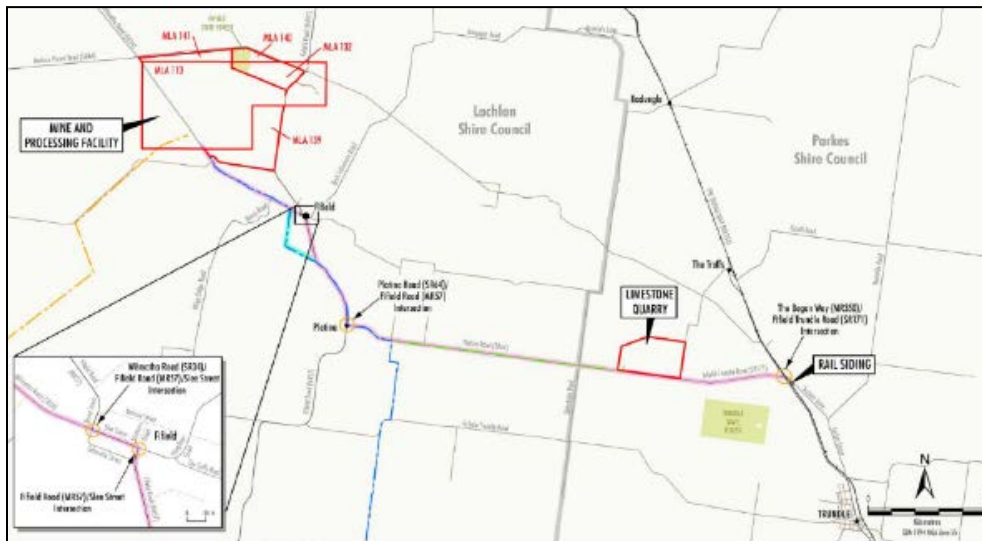

One of the Clean TeQ Sunrise Project's competitive advantages is its proximity to existing infrastructure. The Clean TeQ Sunrise Project is located ~80 km from the Moomba–Sydney natural gas pipeline, a rail line within 20 km of the Clean TeQ Sunrise Project and bitumen roads providing good access to the site. The major centres have excellent infrastructure including transport, airport and rail facilities, all of which can service the Clean TeQ Sunrise Project's requirements. The Clean TeQ Sunrise Project and associated infrastructure are located within the shires of Lachlan and Parkes. The borefield providing the bulk of the water for the Clean TeQ Sunrise Project is located in the Forbes Shire.

Mineral Titles and landholding

The Exploration Licence (“EL”) and Mining Lease Applications (“MLAs”) for the Clean TeQ Sunrise Project are shown in Figure 1-3 and summarized in Table 1-1 below.

Figure 1-3: Tenement ownership overview

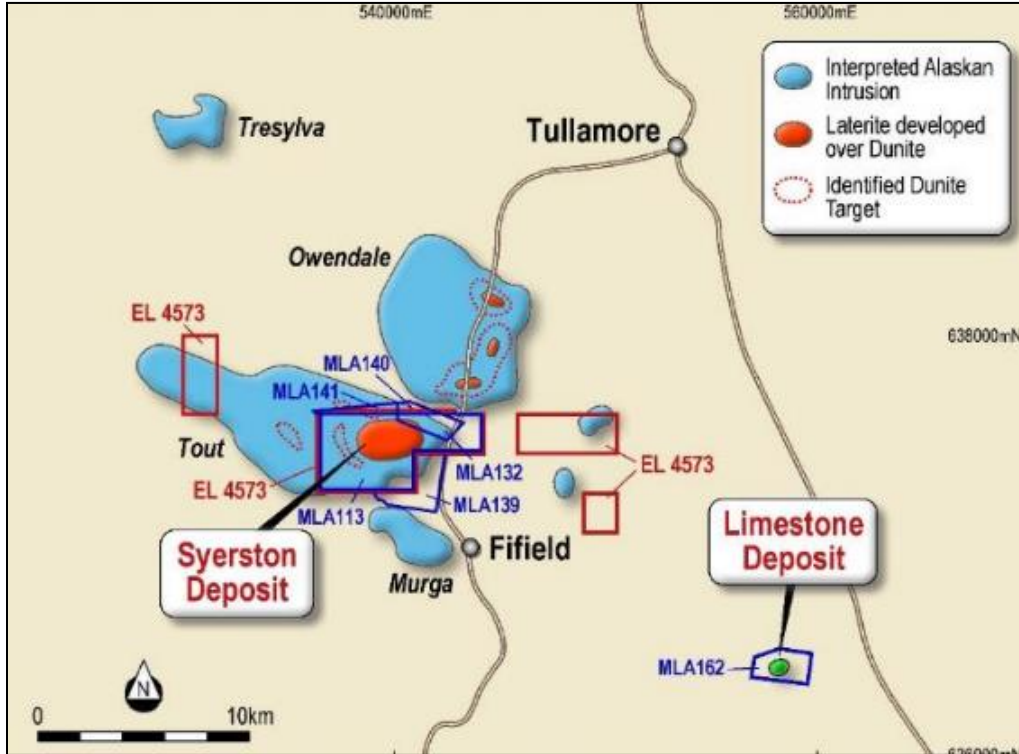

Table 1-1: Exploration Licenses and Mining Lease Applications

License	Status
MLA 113	Mining Licence Under Application
MLA 132	Mining Licence Under Application
MLA 139	Mining Licence Under Application
MLA 140	Mining Licence Under Application
MLA 141	Mining Licence Under Application
MLA 162	Mining Licence Under Application
EL 4573	expires on 16 August 2018
EL 8561	expires on 11 May 2020

EL 4573 covers the area of the Clean TeQ Sunrise Project and its associated facilities. EL 4573 has been granted, subject to the provisions of the *Mining Act 1992* and the conditions of the licence.

In accordance with the *Mining Act 1992*, applications for the Mining Leases required for the mine, the processing and associated infrastructure have been made. The Mining Lease applications cover the entire Clean TeQ Sunrise Project area and can be converted to Mining Leases upon final application to the government. An application to issue the Mining Lease has been made and is in the process of being determined.

The Company also owns a portion of the land in the Clean TeQ Sunrise Project area. The Clean TeQ Sunrise and Kingsdale properties represent two thirds of the total project area. The Company is currently negotiating a Land Purchase Option Agreement over the Slapdown property. The Company also owns the main portion of land over a limestone deposit, Westella to the east of the Syerston Project. The Company is currently in negotiating a Land Option Agreement over The Troffs property. All properties are currently tenanted (Figure 1-4).

The grant of a Mining Lease over freehold land requires, for practical purposes, the consent of the landholder. Scandium21 has purchased most of the land over the project area to ensure that obtaining such consent will not delay the Mining Leases being granted. Land ownership provides a significant advantage for the approval of these Mining Leases.

Figure 1-4: Scandium21's landholding – main project area (left) and limestone quarry (right)

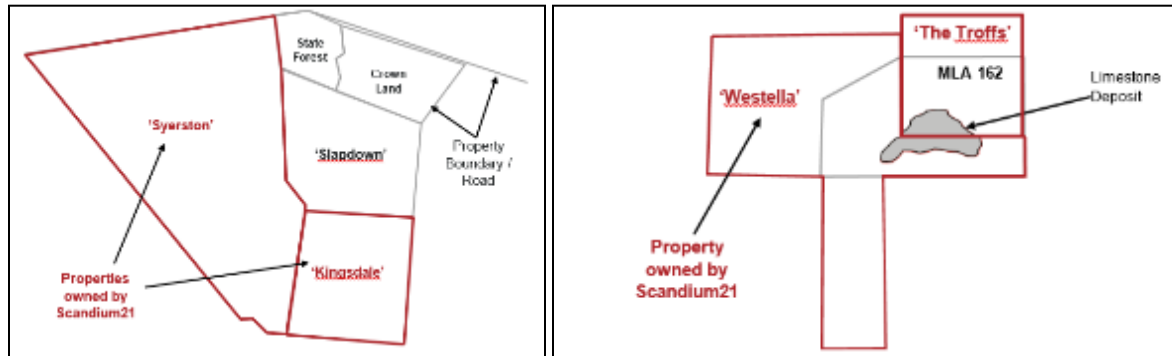

Scandium21 has been granted EL 4573; the licence is due to expire on August 16, 2018, but can be renewed, subject to compliance with the provisions of the *Mining Act 1992* and the licence conditions. The licence confers exclusive rights to prospect in the exploration area for Group 1 minerals, including rare earth minerals, nickel, cobalt and platinum.

Virtually all of the land required for project implementation is freehold land (much of it owned by Scandium21). As a result, there is minimal risk of any future exposure to Native Title claims.

Easement agreements are proposed in order to secure land required for the gas pipeline. Land option agreements and land purchase agreements are proposed in order to secure the land required for the rail siding and proposed bypass road around the town of Fifield. At the time of reporting, Clean TeQ had agreed terms to acquire the land that is the subject of the rail siding (documented and binding, though not yet completed or settled)

Mineral Resources and Mineral Reserves

Based on this modelling described above, a mineral resource and mineral reserve estimate for nickel and cobalt was produced (Table 1-2) with an effective date of October 5, 2016, and forms the basis of the PFS.

Table 1-2: Clean TeQ Sunrise Project Mineral Resource estimate at 0.6% NiEq cut-off

Cut-off NiEq %	Classification	Inventory (Mt)	NiEq* (%)	Grade (% Ni)	Cont. Metal (Ni kt)	Grade (% Co)	Cont. Metal (Co kt)
0.6	Measured	52	1.05	0.73	380	0.109	57
0.6	Indicated	49	0.87	0.58	280	0.101	49
0.6	<i>Meas + Ind</i>	<i>101</i>	<i>0.97</i>	<i>0.65</i>	<i>660</i>	<i>0.105</i>	<i>106</i>
0.6	Inferred	8	0.83	0.54	50	0.098	8

Notes:

- (1) Mineral resources are stated according to CIM guidelines and include Mineral Reserves.
- (2) Tonnes and contained metal are rounded to the nearest thousand.
- (3) Totals may appear different from the sum of their components due to rounding.
- (4) A cut-off grade of 0.6% NiEq, NiEq% = Ni% + (Co% x 2.95)
- (5) US\$4/lb, cobalt at US\$12/lb and a nickel recovery of 90% and cobalt recovery of 88.9%, US\$:A\$ of 0.75.
- (6) The Mineral resource estimation was verified by Danny Kentwell, FAusIMM, who is a full-time employee of SRK. Mr. Kentwell is the Qualified Person under NI 43-101 and the Competent Person for the Resource.

A new database was developed for the 2017 standalone resource model, sourcing data from original historical material as far as possible. A revised geological interpretation was undertaken utilising the major element (Fe, Si and Al) and minor element (Ni and Co) chemistry to identify the chemical characteristics of the various zones within the laterite profile.

Resource estimation was carried out on domain basis, using ordinary kriging and a resource classification was developed based on data spacing and geological and statistical confidence. The majority of the nickel cobalt resource is in the measured and indicated resource categories.

Table 1-3 Clean TeQ Sunrise Cobalt/Nickel Mineral Resource Estimate at 0.06% Co Cut-off effective date October 30, 2017

Classification	Tonnes	Co Grade	Ni Grade	Co Metal	Ni Metal
Category	Millions	%	%	Tonnes	Tonnes
Measured	40	0.15	0.75	59,000	298,942
Indicated	47	0.12	0.55	58,000	259,479
Measures + Indicated	87	0.13	0.64	116,000	558,421
Inferred	14	0.11	0.24	16,000	34,643
Total	101	0.13	0.59	132,000	593,070
<i>Rounding errors may occur</i>					

Table 1-4 Clean TeQ Sunrise Cobalt/Nickel Mineral Resource Estimate at a 0.08 % Co Cut-off effective date October 30, 2017

Classification	Tonnes	Co Grade	Ni Grade	Co Metal	Ni Metal
Category	Millions	%	%	Tonnes	Tonnes
Measured	29	0.18	0.78	51,000	227,000
Indicated	32	0.15	0.57	47,000	183,000
Measures + Indicated	61	0.16	0.67	98,000	410,000
Inferred	10	0.13	0.25	13,000	25,000
Total	71	0.16	0.61	111,000	435,000
<i>Rounding errors may occur</i>					

Table 1-5 Clean TeQ Sunrise Cobalt/Nickel Mineral Resource Estimate at a 0.10 % Co Cut-off effective date October 30, 2017

Classification	Tonnes	Co Grade	Ni Grade	Co Metal	Ni Metal
Category	Millions	%	%	Tonnes	Tonnes
Measured	22	0.20	0.80	44,000	175,000
Indicated	21	0.18	0.59	38,000	126,000
Measures + Indicated	43	0.19	0.70	82,000	302,000
Inferred	7	0.15	0.25	10,000	17,000
Total	50	0.19	0.64	93,000	318,000
<i>Rounding errors may occur</i>					

Table 1-6 Clean TeQ Sunrise Scandium Mineral Resource Estimate (300 ppm Sc Cut-off) effective date October 30, 2017

		Mt	Sc ppm	Sc metal	Sc2O3
Alluvial	Measured				
	Indicated	1.12	368	411	629
	Inferred	7.29	366	2,671	4,086
Overburden	Measured	0.01	348	2	4
	Indicated	1.29	395	511	781
	Inferred	17.01	421	7,158	10,952
Transition	Measured	0.40	434	174	266
	Indicated	2.28	414	945	1,446
	Inferred	1.87	446	833	1,274
Goethite	Measured	0.91	512	467	714
	Indicated	2.82	443	1,251	1,914
	Inferred	3.98	536	2,133	3,263
Sliceous Goethite	Measured	0.44	439	191	293
	Indicated	3.05	401	1,223	1,871
	Inferred	3.19	392	1,252	1,916
Total	Measured+Indicated	12.32	420	5,175	7,918
	Inferred	33.34	421	14,047	21,492
	Total	45.66	421	19,222	29,409

Table 1-7 Clean TeQ Sunrise Platinum Mineral Resource Estimate effective date October 30, 2017

Pt Cutoff	Class	Mt	Pt g/t	Ounces
0.15	Measured	36.68	0.37	431,491
	Indicated	52.33	0.30	509,065
	Measured+Indicated	89.01	0.33	940,557
	Inferred	14.08	0.30	135,614
	Total	103.09	0.32	1,076,170
0.50	Measured	5.33	0.94	161,773
	Indicated	5.16	0.70	116,792
	Measured+Indicated	10.49	0.83	278,565
	Inferred	1.65	0.79	41,713
	Total	12.15	0.82	320,278
1.00	Measured	1.06	2.12	72,507
	Indicated	0.43	1.47	20,269
	Measured+Indicated	1.49	1.93	92,776
	Inferred	0.23	1.44	10,745
	Total	1.73	1.87	103,521

The Mineral Reserves are based on a calculated block value and cut-off grade. Only measured and indicated mineral resources have been converted to Proven and Probable Mineral Reserves. The Mineral Reserves have been estimated using the Australasian Code for Reporting of Exploration Results, Mineral Resources and Ore Reserves 2012, JORC Code (2012). The 2016 mineral resource figures set out above were used as the basis for the mineral reserve figures below. The mineral reserves are shown in Table 1-.

Table 1-8: Clean TeQ Sunrise Project Mineral Reserve (as autoclave feed tonnes) effective October 5, 2016

Category	Inventory (Mt)	NiEq (%)	Cont. Metal (NiEq kt)	Grade (% Ni)	Cont. Metal (Ni kt)	Grade (% Co)	Cont. Metal (Co kt)
Proved	59.48	0.96	571	0.71	422	0.1	59
Probable	44.23	0.83	367	0.58	257	0.1	44
Total	103.71	0.91	944	0.65	674	0.1	104

Notes:

- (1) Tonnes are rounded to the nearest thousand.
- (2) Totals may appear different from the sum of their components due to rounding.
- (3) A cut-off grade based on NSR was used of approximately 0.25% NiEq, $NiEq\% = Ni\% + (Co\% * 2.95)$
- (4) US\$ 7.50/lb nickel and US\$12/lb cobalt and nickel recovery of 90% and cobalt recovery of 88.9%, US\$: A\$ of 0.75.
- (5) For economic modelling a cobalt price of US\$14/lb was used and US\$ 7.20/lb for nickel
- (6) The Mineral Reserve is a subset of the Measured and Indicated only schedule of a Life of Mine Plan that includes mining of Measured, Indicated and Inferred Resources.
- (7) The Mineral Reserve estimate was independently verified by Peter Fairfield, FAusIMM, CP (Mining), who is a full-time employee of SRK and a Qualified Person under NI 43-101.

Mining costs were provided from contractor submissions in 2016. The block value in the mining model was calculated by incorporating the estimated processing cost (fixed and variable), metal recoveries, metal prices and the average acid consumption cost for different rock types.

The net smelter return (NSR) was calculated as the revenue less operating costs (excluding mining). The metal prices used for the block value were US\$7.50/lb Ni and US\$12.00/lb Co. Scandium has not been included.

The Mineral Reserve is based on the marginal cut-off grade and a block value of A\$50.00/t, which equates to an NSR A\$50.00/t or 0.25% NiEq. For the purpose of maximising NPV in scheduling, each block was assigned a Low Grade (low grade), Medium Grade (medium grade) or High Grade (high grade) subcategory value.

Geological Setting, Mineralization, Deposit Types and Drilling

The deposit lies over a mafic to ultramafic intrusive complex known as the Tout Complex. The lateritic weathering profile in which nickel, cobalt, scandium and platinum accumulated developed preferentially over the dunite core of the intrusion, which is about 4 km by 2 km in area. Over the dunite, the laterite profile can be up to 35 - 40 m thick, but thins markedly over surrounding pyroxenites so that it has a basin-like form.

Several Tertiary drainage channels cut across the deposit. These reach depths of 20 - 25 m and are now filled with barren alluvium. The laterite profile is best developed on old Tertiary hilltops between these palaeo-drainages that divide the deposit into two main parts.

Figure 1-5: Geology of the Clean TeQ Sunrise Project area

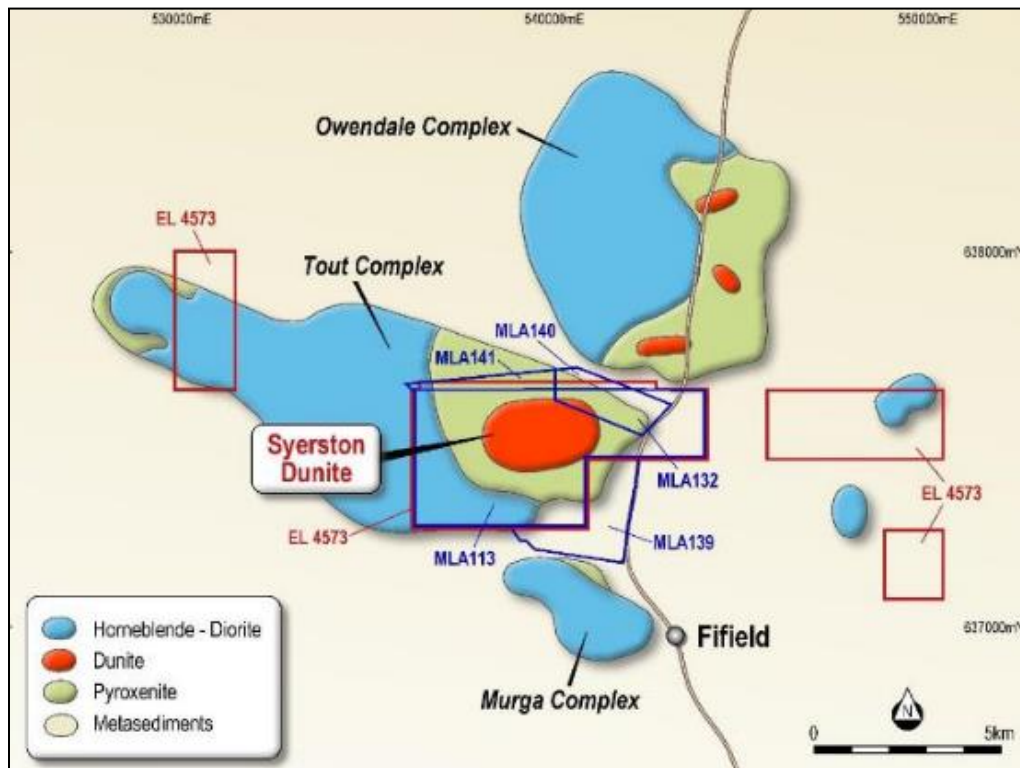

Historically, 1,200 drill holes have been drilled in several drill campaigns. Significant drilling was carried out on the dunite core, with minimal drilling along the periphery of the historical nickel/ cobalt deposit. A 2014 - 2015 drilling campaign focused on identified high grade scandium zones to the

northwest of the deposit; however, these have not been included in this resource, as nickel and cobalt mineralisation present in these areas is very limited.

A 3D geological model was developed to cover the full extent of the interpreted high grade pods. Resources estimation was based on all data that was considered reliable. The majority of the nickel cobalt resource is in the Measured and Indicated Resource categories. The nickel and cobalt metal distribution in the main geological unit is shown in Figure 1-6.

Figure 1-6: Projected plan view of nickel and cobalt metal distribution

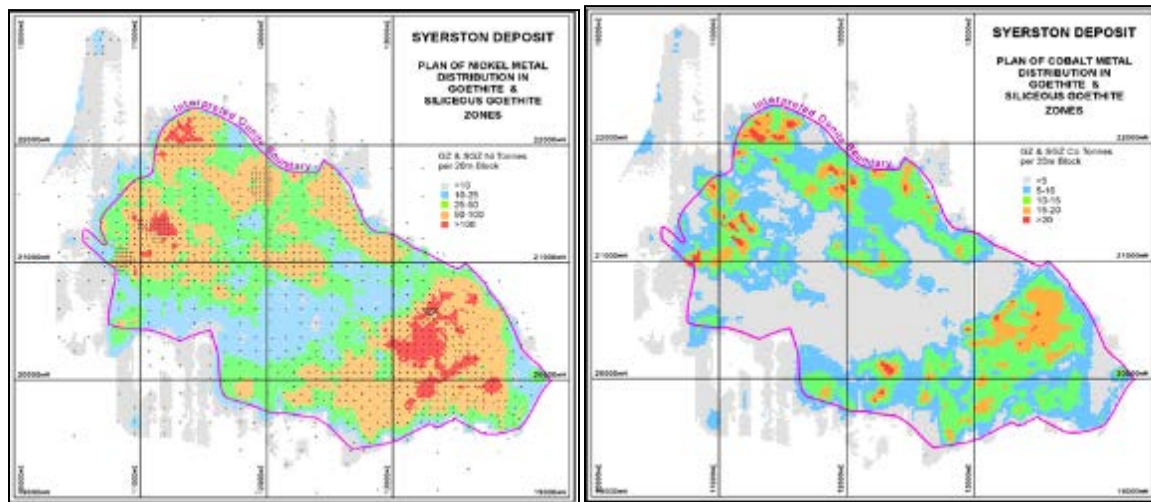

Sampling, Analysis and Data Verification

Sampling

Until 1998, Australian Laboratory Services Pty Ltd (“ALS”), located in Orange, New South Wales, was the primary laboratory for sample preparation and assaying, although there is mention in some older reports describing exploration that the ALS laboratory in Brisbane, Queensland, was also involved to some unknown extent.

From late 1998 onwards, Ultratrace Analytical Laboratories (Canning Vale, Western Australia) became the primary laboratory, with Genalysis Laboratory Services (Genalysis) in Maddington, Western Australia, used for check assays. This remained the case in 2005.

Between 2014 and 2015, samples were assayed at ALS in Brisbane, Queensland, after sample preparation at ALS’ facilities in Orange, New South Wales.

In 1999, significantly mineralised intervals from previous aircore holes (>0.4% Ni) and from RC holes up to SRC340 drilled between 1995 and 1998, were re-assayed at Ultratrace. The intervals involved were apparently selected on the basis of a Ni equivalent value >0.25%, apparently using the formula $NiEq\% = Ni\% + (Co\% \times 3.64)$.

A separate program of independent custody sampling has been conducted for the 2017 mineral resource estimate. A twin RC and diamond drill hole program was designed to test 10 RC drill holes from the historic resource definition drilling. A twin RC hole was positioned approximately 5m diagonally from the previous RC hole in the NE quadrant, whilst a diamond hole was to be drilled in a similar location in the SW quadrant. The holes were positioned to provide a spatial spread between the eastern and western mineralised zones and to optimise the intervals of the Goethite Zone and Salicious Goethite Zone within the planned holes. The holes were drilled adopting the current sample protocol and logging procedures

and were observed by an experienced sample technician to record the procedures and report on behalf on the qualified person.

This process was fully documented to identify a 'chain-of-custody' for the sampling procedures and was followed through to the delivery of the samples at the routine laboratories sample preparation facility, where the technician ensured that during the procedures, the samples were under scrutiny of responsible personnel at all stages. The sample interval data was compiled by the senior geologist on site and on receipt of the assay results files, was forwarded to the qualified person for comparison with the historic data. The hole location, survey and sample data were compiled as load files for the drill hole database directly from the site geologist's records. They were imported into the drill hole database together with the laboratory assay file. Subsequently, the collar, survey and assay files were exported from the database in Micromine format.

Data Verification

SRK had access to the input data, working files and final resource model completed by McDonald Speijers in 2015. SRK reviewed the detailed technical reports by McDonald Speijers for the 2005 and 2015 resource estimate in detail and used them to form the basis of this current report in a merged, summarised and updated form.

SRK has knowledge of McDonald Speijers and its lengthy history of involvement in the mining industry in Australia and overseas. SRK has no reason to consider that the work and reports by McDonald Speijers are anything other than professional and to have been completed in accordance with both the Australian JORC Code and the Canadian CIM definition standards.

SRK used the drilling database as supplied by McDonald Speijers and independently reproduced the resource tonnages and grades at 0.6% NiEq cut-off to within 10%.

In SRK's opinion, the robustness of the resource tonnages and grades is demonstrated by the negligible changes in the resource tonnage and grades over the last three resource estimates (1999, 2005 and 2015), with additional drilling included in each update. The multiple phases of drilling and the different owners and the different laboratories used all point to confidence in the robustness of the overall resource.

Security of Samples

Prior to 2005, no particular security measures were imposed during sample transport between the drill rig and the laboratory. Consequently, the possibility of outside interference cannot be totally excluded for this time period, but the style of the nickel and cobalt mineralisation is not particularly amenable to tampering. An independent custody sampling check was conducted by SLA in 1999, which indicated that tampering was unlikely to have occurred.

In 2005, uniquely numbered plastic security tags were attached to each poly-weave sacks of samples at Fifield prior to despatch. Sample security forms were completed at Fifield, Australia and a copy was returned to the laboratory. These showed the seal number, drill hole number and number of samples for each sack. On receipt of the samples, the laboratory checked that the seal on each sack was intact, and that it contained the correct samples. The laboratory then marked and initialled the form accordingly and returned a copy to Ivanplats. The security arrangements in 2005 were adequate.

Mining, Processing and Recovery Operations

Mining is planned to be undertaken by conventional open pit methods, using conventional excavators and trucks. Scandium21 will engage the services of a mining contractor to operate the open pits. The contractor will also be responsible for the mining related construction activities, including the run of mine (ROM) pad, limestone pad and haul road construction, and maintenance during operations. The actual equipment to be used will be agreed with the selected mining contractor, to allow ore selectivity within the pit and requirement for high manoeuvrability between the pits to be maintained.

Mining activities will begin with the development of roads to allow access to all areas of the deposit and material haulage in all weather conditions. This will entail the provision of a hard and suitably draining road base. Establishment of all-weather access roads will be followed by carefully managed clearing of the mine sites themselves. It is assumed that the removal of vegetation will be carried out mechanically, followed by transport to a designated area.

Pit Model and Mine Schedule

In the 2005 Study, pit optimisations were undertaken on the 2005 resource model with relevant dilution, cost, revenue and geotechnical inputs taken into consideration. The optimisation pit shells were used for detailed pit design, taking ramps and geotechnical considerations into account.

Pit designs were not prepared as a basis for the Clean TeQ Sunrise Technical Report. The Clean TeQ Sunrise Technical Report uses the 2005 open pit designs – it is considered that as there were limited changes to the resource, the updated pit optimisation is likely to be similar to the results of the 2005 Study. Waste dumps and stockpiles were designed to accommodate the volumes in the mine schedule. SRK recommends that updated pit optimisations and pit designs be undertaken in the further study work to confirm the pit staging and to optimize the mineral reserve, ore and waste schedules.

SRK reviewed the work undertaken to support the PFS. SRK has verified and validated the outputs from the mining studies to satisfy itself of the integrity of the work.

Figure 1-7: Pit model for LOM operation

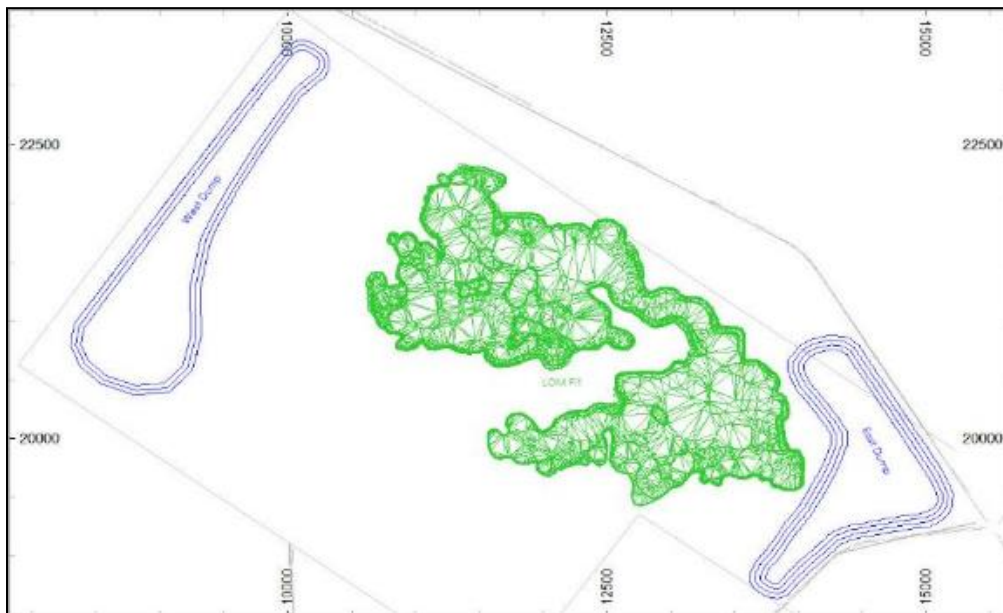

The Clean TeQ Sunrise Project NPV was maximised by scheduling the high grade ore as plant feed for the first 10 years of the project. Following this, stockpiled low grade and medium grade ore will also feed the plant until the completion of mining. Figure 1-8 shows ore will be fed to the autoclave at a rate of 2.5 Mtpa. Mining is estimated to be completed in Year 25, with the feeding of stockpiled material being completed in Year 44.

Figure 1-8: Annualised LOM plant feed

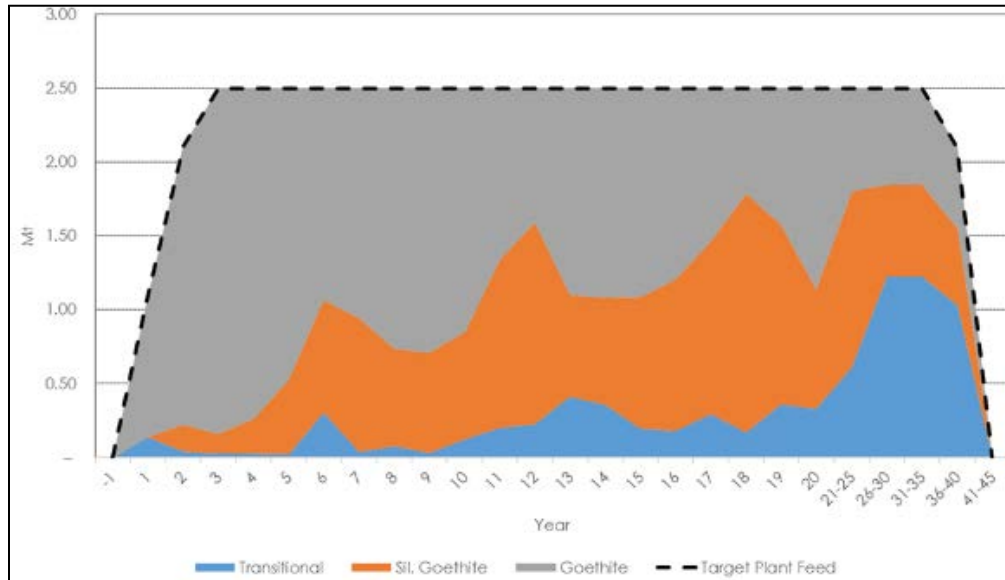

Limestone feed is required for acid neutralisation at the plant. The Westella limestone deposit is located approximately 22 km to the southeast of the proposed Clean TeQ Sunrise Project mine and processing facility. The design work undertaken in the 2005 Study for mining limestone from Westella was used for the PFS and the operating costs were updated in the PFS.

High grade limestone will be crushed and stockpiled at the quarry ready for transport by a mining contractor. Low grade limestone and waste material will be stockpiled separately, so that low grade limestone can be reclaimed at a later stage, if required.

It was identified that there would be sufficient high grade limestone feed in the current model for approximately 17 years. Scandium21 indicated that the resource continues to the north, but further drilling is required in order to prove this. For the purpose of the mining study, it was assumed that the limestone resource continues to the north, and all mining constraints remained constant, i.e. specific gravity (SG), strip ratio, etc.

High pressure acid leach

The Clean TeQ Sunrise Project has selected HPAL and continuous RIP, along with downstream impurity removal, solvent extraction and crystallisation, as the processing route for the separate high purity nickel sulphate and cobalt sulphate products.

There is a high degree of confidence in the robustness of the HPAL process to extract nickel and cobalt from lateritic ores. The HPAL processing technology is generally considered to be in its fourth generation and is much improved by the experience gained from its use in operating plants. While challenges in commissioning and ramping up HPAL operations remain, these challenges are well understood. Commercial HPAL processing of laterites commenced at Moa Bay in Cuba in the late 1950s. Since that time, several large HPAL plants have been constructed and successfully operated on laterites for nickel and cobalt extraction. These include plants at the Bulong, Cawse, Murrin Murrin, Ravensthorpe, Coral Bay, Ambatovy, Taganito and Goro operations.

The metallurgical testwork completed in the two previous feasibility studies on the Clean TeQ Sunrise Project typically followed nickel, cobalt and scandium. All historical testwork confirms that scandium extraction using the HPAL process ranges from 80% - 90%, and is sometimes higher.

Resin-in-pulp

Clean TeQ uses its proprietary ion exchange technology (Clean-iX®) for the extraction and purification of metals. The base technology for the Clean-iX process was developed by the All Russian Research Institute of Chemical Technology (“ARRICT”) over a period of 40 years.

Since 1951, ARRICT has been involved in the development of over 30 mining operations using the technology, mainly for uranium and gold extraction, from leached slurries and solutions. In 2000, Clean TeQ obtained the exclusive licence (the “**License**”) for all technical information relating to ion exchange resin, ionic membranes, organic solvent extractants, including manufacturing know-how and plant design, for all countries outside the former Soviet Union. The License is for a term of 99 years, expiring in 2105. Clean TeQ has an ownership right over any improvements it develops with respect to the technology underlying the License. Since obtaining the Licence, Clean TeQ has further developed the technology for base metals, uranium and gold, with particular improvements in relation to laterite ore processing, scandium and uranium. Clean TeQ has been granted 10 additional patents on various aspects of the technology, including one for extraction and purification of scandium.

The application of resin-in-pulp (“**RIP**”) for scandium recovery is based on commercially applied (for other metals) and developed equipment and technologies and has the potential to offer significant benefits for nickel, cobalt and scandium recovery at the Clean TeQ Sunrise Project, including improved metallurgical recoveries and lower capital and operating cost. Conventional flowsheets in the industry currently use counter current decantation (“**CCD**”) followed by precipitation of either a mixed sulphide or hydroxide intermediate, re-leaching and solvent extraction to recover the metals from leached slurries. This process has several disadvantages, including higher capital and operating costs, and lower metal recoveries. The use of RIP technology addresses many of these issues. The RIP method uses solid ion exchange resin beads which are contacted directly with the leached slurry, resulting in extraction of more than 98% of the contained metal in the solution. Ion exchange resins are ideal for recovery and concentration of lower concentration metals, which is the case with lower grade laterite resources. A benefit is that the plant size and chemical reagent costs are reduced in comparison with solvent extraction

Clean TeQ’s development of the nickel, cobalt and scandium RIP process since 2001 includes three large-scale piloting operations on laterite ore. Furthermore, Clean TeQ has developed a process for scandium recovery from titanium dioxide process streams and has a fully automated pilot plant operating on such process streams.

In 2007 Clean TeQ sold the ion exchange technology to BHP Billiton SSM Development Pty Ltd (which later novated it to Cerro Matoso S.A., a subsidiary of South32) for application in the field of recovery of nickel, cobalt and associated elements from:

- (a) nickel-bearing ores;
- (b) intermediate products resulting from the processing of nickel-bearing ores; and,
- (c) tailings, residues, wastes or byproducts (including process water) resulting from the processing of (a) or (a).

In 2016 Clean TeQ acquired a sub-licence for the technology from Cerro Matoso for the Clean TeQ Sunrise Project.

Metallurgical testwork summary

Extensive metallurgical piloting on the extraction and recovery of nickel and cobalt was completed by the two previous owners and included variability testing of more than 100 composites of different ore lithologies. This work has provided a solid basis on which to establish the design criteria for the nickel/cobalt/ scandium Project. During each of these testwork programs, nickel and cobalt were the primary targets, but scandium was also analysed. This work provides a relatively high degree of confidence on

metal extraction using the HPAL process and subsequent unit process design criteria. In addition to this earlier work, basic sighter tests were carried out to confirm the results of previous metallurgical testwork.

Clean TeQ's more recent metallurgical testwork and processing development focus was applying the RIP technology, a change to the original processing flowsheet, to the HPAL discharge slurries.

The Clean TeQ Sunrise Project ores have been shown to have relatively low acid consumptions, typically 240 - 290 kg/t. This is a key advantage for the Clean TeQ Sunrise Project as acid consumption makes up a significant proportion of the total operating costs. HPAL testing has also demonstrated high leach extractions – over 97% and 95.5% for nickel and cobalt respectively – and higher overall metal recoveries.

Processing plant

A complex hydrometallurgical processing flowsheet using conventional HPAL to leach nickel and cobalt from the Clean TeQ Sunrise Project ores will be used at the proposed Clean TeQ Sunrise Project processing plant. The leached nickel and cobalt is then recovered through nickel and cobalt RIP and SX before the final nickel sulphate and cobalt sulphate products are crystallised, dried, packaged and transported to market. Optionally, a third scandium oxide product can be produced from the raffinate liquor streams, again using scandium RIP, scandium refining and final calcination.

Figure 1-9 shows an overview of the processing options considered for this study. Although the optional scandium oxide production option is shown, this option is not currently incorporated in the detailed flowsheet that forms the basis of the capital and operating costs.

Figure 1-9: Process flowsheet

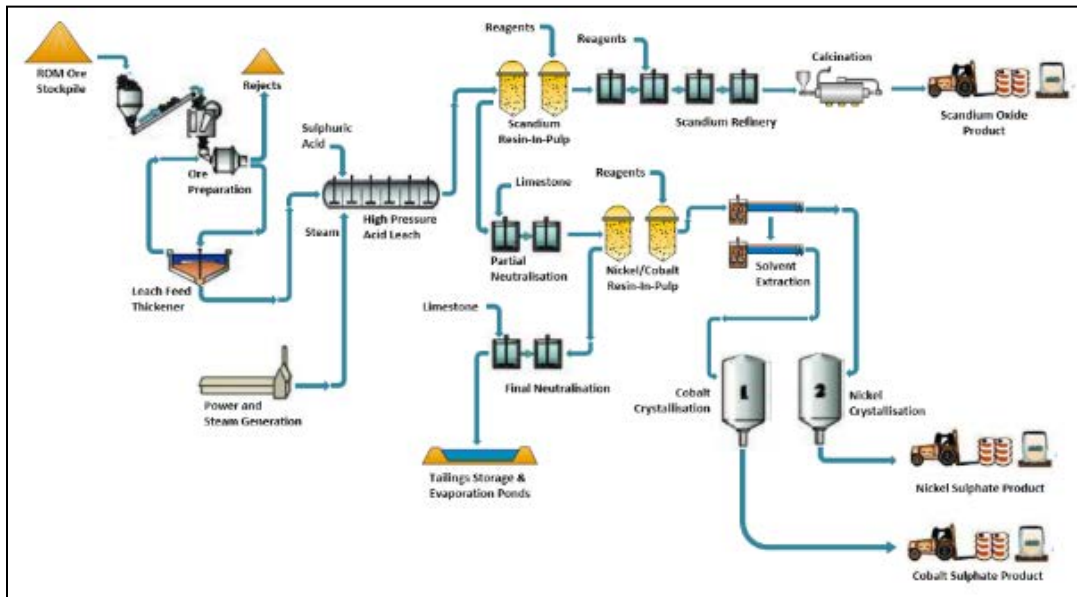

Detailed descriptions of each process are provided in the Technical Report. The process can be broadly defined as:

- Ore Preparation and Milling
- HPAL
- Scandium RIP (optional, but not included in cost estimate)
- Scandium purification (optional, but not included in cost estimate)
- Nickel/ cobalt RIP

- Nickel/ cobalt sulphate purification and recovery
- Tailings neutralisation and storage
- Process reagents and utilities (sulphuric acid, steam, water, limestone, other).

The final slurry/ solution after metal recovery is neutralised with limestone and sent to a tailings storage facility (“TSF”) and an evaporation pond. The process plant will produce high purity hydrated nickel and cobalt sulphate products, as well as a 99.9% Sc₂O₃ product (optional).

Hydrated nickel and cobalt sulphates

The process plant has been designed to produce high purity hydrated nickel sulphate (NiSO₄.6H₂O) and hydrated cobalt sulphate (CoSO₄.7H₂O) products. The product from the elution circuit of the RIP plant is a high concentration, high purity combined nickel and cobalt sulphate solution. Therefore, the process is ideally suited to the lithium-ion battery sector, which requires sulphates for precursor production, and potentially eliminates process steps that exist in the current cathode supply chain.

Based on historical data taken from the 2005 Study update, the 2016 Scandium Feasibility Study and Clean TeQ’s internal database of nickel and cobalt recovery using the RIP process, the process design criteria (PDC) were developed for the PFS. Table 1- provides a summary of the key process parameters for each option over the initial 20-year mine life.

Table 1-9: Process design criteria summary

Operating hours per year	hours p.a.	7,690
Availability Leach Plant	%	89.6
Mine Life	years	>20
Average Product Production (Years 3 - 20)		
Nickel Sulphate (NiSO ₄ .6H ₂ O)	tpa	85,136
Cobalt Sulphate (CoSO ₄ .7H ₂ O)	tpa	15,490
Nickel Equivalent Production	tpa	18,730
Cobalt Equivalent Production	tpa	3,222
<i>Scandium Oxide (Sc₂O₃) - Optional</i>	<i>tpa</i>	<i>~ 50</i>
Nickel Grade (Average)	%	0.80
Cobalt Grade (Average)	%	0.14
Nickel Grade (Range)	%	0.7 - 1.0
Cobalt Grade (Range)	%	0.1 - 0.2
Scandium Head Grade (Range)	ppm	40 - 60

Autoclave Operating Temperature	°C	250
Autoclave Residence Time	minutes	70
Sulphuric Acid to Leach	kg/t	240 - 290
Estimated Leach Extractions (Goethite)		
Nickel	%	97
Cobalt	%	95.5
Scandium	%	86
RIP Metal Recovery (Ni/ Co & Sc)	%	98
Estimated Overall Recoveries (Goethite)		
Nickel	%	93.5
Cobalt	%	92.7
Scandium	%	83.4

The mine production schedule is based on the 2005 Study update, in which production of cobalt was capped at 5,000 tpa, as the main focus was nickel production. However, there is potential to alter the mine plan such that higher grade cobalt is mined, particularly in the early years of the operation.

Infrastructure, Permitting and Compliance Activities

One of the Clean TeQ Sunrise Project's competitive advantages is its proximity to existing infrastructure. The Clean TeQ Sunrise Project and associated infrastructure are located within the shires of Lachlan and Parkes, while the borefield providing most of the raw water for the Clean TeQ Sunrise Project is located in the Forbes Shire.

The proposed Project infrastructure facilities are representative of those required to support a modern 2.5 Mtpa complex hydrometallurgical plant and open pit mining operation. The Clean TeQ Sunrise Project is located relatively close to the Moomba–Sydney (natural gas) pipeline, a rail line is located within 20 km of the Clean TeQ Sunrise Project, giving it access to the ports of Sydney and Newcastle. Major bituminised arterial roads provide good access to the site. The major city and town centres have excellent infrastructure, including transport, airport and rail facilities, all of which are available to service the requirements of the Clean TeQ Sunrise Project. The workforce would be accommodated in the local communities.

The Clean TeQ Sunrise Project infrastructure comprises the following:

- Access road, internal roads and haul road
- Rail siding
- Integrated power station, high pressure steam boiler and acid plant
- Site buildings - office and administration complex, workshops, stores, ablutions and change house, fences and security

- IT and communications systems
- Sewage plant
- Store and laydown facilities
- Ore stockpiles and waste stockpile area
- ROM stockpiles
- Processing plant and associated facilities
- Raw water storage to manage rainfall runoff
- Process plant and mining workshops
- Tailings storage facilities
- Evaporation ponds
- Borefield
- Reverse osmosis plant
- Analytical and metallurgical laboratory
- Mobile equipment
- Diesel fuel storage.

The bulk of the raw water demand will be sourced from the Clean TeQ Sunrise Project's borefield 65 km south of the mine which is licenced for an abstraction rate of 3.2 GL/annum. This amount covers water requirements in terms of potable water, fire water, high pressure hose-down water, mine utility water and plant water for use in the process, as well as feed to the water treatment plant producing high purity water for steam production. During the 2005 Study, the volume of raw water from the borefield was not sufficient to meet the Clean TeQ Sunrise Project's entire raw demand and it was intended that this was to be supplemented with water taken directly from the Lachlan River. At the time, approvals were not obtained for this supplementary water source. A detailed Project water balance has not been updated as part of the PFS; however, this work is being undertaken as part of the ongoing DFS. While the current project is reducing water demand, it is likely that supplementary water will be required. Alternative sources of supply may need to be considered if the appropriate approvals are not obtained in the future. Clean TeQ plans to finalise the water the water balance as part of the DFS before engaging a water broker to secure any additional water requirements.

Natural gas is transported to site by means of a new natural gas pipeline. Gas is used as an energy source for heating water to convert to high pressure steam used in the leaching process, as well as for electricity, via a gas-fired generator. The pipeline branches off from the existing Moomba-Sydney natural gas pipeline, passes near Condobolin and runs north to deliver natural gas to a metering station at the southwest corner of the Clean TeQ Sunrise Project process plant. The Clean TeQ Sunrise Project is not sufficiently advanced to enter into formal negotiations for the supply or transmission of natural gas. Due to the quantity required, it is more likely that supply will be arranged through a retailer/ gas aggregator rather than the primary producer. Gas suppliers, such as AGL, Alinta and Origin, have confirmed that there is sufficient capacity in the pipeline to supply the Clean TeQ Sunrise Project, which is in the order of 2.4 TJ/day of firm (not interruptible) supply. The APA Group (the owner and operator of the pipeline) has been re-engaged regarding the new pipeline and has confirmed its ability to build and operate, but the APA Group has not yet provided pricing, which will be based on the natural gas demand established in the DFS engineering work. The pipeline operator and gas providers advised that insufficient gas availability will not be a risk to the Clean TeQ Sunrise Project, but pricing is less certain and there is a risk of escalating prices.

Sulphuric acid will be produced on site with a dedicated acid plant capable of making 2,700 tpd of sulphuric acid. This incorporates a sulphur receipt system incorporating sulphur handling, stockpile and reclaim areas designed to receive sulphur delivered by end-tipping road trains at regular intervals. Sulphur would be railed to a local siding located between the towns of Trundle and Fifield and loaded into end-tipping road trains. The acid plant will also produce high pressure steam at 6,000 kPa and

450°C. This steam is exported to the power plant where it is desuperheated for distribution to the process plant users. Any surplus steam is used in the power plant for power generation, and provides the potential to offset a portion of the site's net energy requirements.

Limestone will be mined in the Company's limestone quarry and trucked to site. The Company holds MLAs over 50% of the quarry and is currently negotiating an option to acquire the remaining interest. Limestone is required for neutralising the process slurries and liquors following acid leaching. In order to meet this requirement, the original 2005 Study approvals to mine a maximum of 600,000 tpa of limestone from the Gillenbine limestone deposit, situated approximately 20 km southeast of the Clean TeQ Sunrise Project, were obtained. The approved design for the quarry presented in the environmental impact statement ("EIS") includes the removal and stockpiling of waste rock and limestone extraction using conventional open pit drill and blast methods. Waste rock and low grade limestone would be deposited in an emplacement surrounding the open pit. All other chemicals will be trucked or railed to site in either B-Doubles, ISO containers, intermediate bulk containers (IBCs) or bulk bags and stored on site in a dedicated reagents area.

The infrastructure design and development has largely been undertaken during the earlier engineering feasibility studies for a 2.0 Mtpa (2000) and 2.5 Mtpa (2005) nickel and cobalt operation completed by the previous owners, Black Range and Ivanplats, respectively. Work was continued by Clean TeQ in 2016 and 2017, specifically associated with the application to modify the Clean TeQ Sunrise Project's "Development Consent", which has now been given. This included Voluntary Planning Agreements (VPAs) with the local Shires outlining the contributions the Clean TeQ Sunrise Project would make in terms of road upgrades, road maintenance and contributions to community-based activities. It also updated other aspects of the Development Consent affecting local community stakeholders, including a review of several key aspects of the infrastructure – public roads, railway sidings, limestone quarry and the natural gas pipeline.

Because of the limited change in the infrastructure for the Clean TeQ Sunrise Project, the capital cost estimate associated with the infrastructure has been factored (by Clean TeQ), based on a SNC-Lavalin cost escalation assessment undertaken in August 2016. Additional allowances have been made for items excluded in previous studies, specifically to upgrade the local road network. A number of other costs have been excluded, such as the building of a gas pipeline, as these will be covered under a build-own-operate (BOO) or supply type arrangement. Firm pricing for these costs has not yet been obtained.

Environment, permitting, social and community

The Development Consent DA 374-11-00 has been modified on three occasions since it was issued in 2005. The most recent modification (in 2016) allows mining and processing operations to initially focus on scandium oxide production and gives approval for adjustments to the processing operations to allow for the production of approximately 80 tpa of scandium oxide and up to 40,000 tpa of nickel and cobalt metal equivalents, as either sulphide or sulphate precipitate products.

Details of the most recent proposed project modifications were set out in a document entitled, "Syerston Project Scandium Oxide Modification Environmental Assessment" (Document No. 00740462, May 2016). The modified development application was approved on May 12, 2017, subject to a range of conditions set out in the Notice of Modification. These conditions include administrative conditions that limit the number of years the mine can operate to 21 years, the ore processing feed rate of the autoclave not to exceed 2.5 million tonnes per calendar year and the transport of not more than 180 tonnes of scandium oxide and 40,000 tonnes of nickel and cobalt metal equivalent from the mine in any calendar year, as well as certain environmental performance conditions related to hours of construction, noise management, air quality and use of water. SRK considers that stakeholder comment on the recent development approval has generally been supportive of the Clean TeQ Sunrise Project and SRK considers it unlikely that third party appeals will arise.

The primary environmental consent required for project implementation has been granted. Based on a review of decisions for comparable recent developments in the general locality, SRK has no reason to expect that the secondary approvals required for the Clean TeQ Sunrise Project would be refused.

Water supply and borefield

Previous water investigations by Coffey in 2000 determined that insufficient water was available in the immediate Project area to meet the historical plant requirements. The closest viable source of sufficient water was the Lachlan River, approximately 65 km to the south of the Clean TeQ Sunrise Project area. Black Range and Ivanplats completed the EIS and Development Consent on the basis of this borefield being established.

Figure 1-10: Borefield overview



Clean TeQ Metals engaged Golder Associates Pty Ltd in March 2015 to determine the current status of water supply in the area. The Golder report concluded that there were no single groundwater or township water source that could meet the required demand. Therefore, the most practical water source remaining for the Clean TeQ Sunrise Project is the established borefield.

On June 13, 2006, the NSW Office of Water granted Water Bore Licences to Ivanplats (former company name of Scandium21) for the extraction of 100 L/s from the Clean TeQ Sunrise Project borefield.

The Eastern and Western borefields were established on the assumption of a duty/ duty/ standby arrangement. To date, one bore in each of the Eastern and Western borefields has been developed, with the Western borefield operating (for local use under a water purchase agreement).

SRK notes that the currently approved volume of water sourced from borefields is not sufficient to meet the Clean TeQ Sunrise Project's entire raw demand and the intention was to supplement with water taken directly from the Lachlan River. At the time of writing this Report, approvals had not been obtained for this supplementary water source. While the water demand current for the Clean TeQ Sunrise Project is currently reducing, it is still likely that supplementary water will be required.

As part of the Feasibility Study, Clean TeQ plans to finalise the water balance as well as assess options to secure rights to any additional water requirements.

Community and stakeholder consultation

A community consultation program is being undertaken for the Clean TeQ Sunrise Project, considering directly affected landowners; surrounding landowners; community groups, businesses and Aboriginal associations; Local Government; and Government Departments and Agencies.

The consultation program aims to keep the community informed about the development of the Clean TeQ Sunrise Project and to provide a means for stakeholders to comment on Project-related issues.

Currently, Clean TeQ has negotiated VPAs with each of the shires affected – Lachlan, Parkes and Forbes – to outline the contributions to community enhancement, road upgrades and ongoing road maintenance once the Clean TeQ Sunrise Project has commenced.

Once the Clean TeQ Sunrise Project progresses to the next stage of development, the community consultation program will be re-initiated.

Economic Results of the PFS

While there are established markets for nickel (stainless steel, alloys and plating) and cobalt (chemicals, super alloys, catalysts), a significant growth sector for both metals is in lithium-ion batteries. Growth in the lithium-ion battery market is driven by the increased consumption of portable electronic devices (mobile phones, laptops, tablets), the electric vehicle (EV) market and growing applications for utility energy storage. Cobalt and nickel are used in the majority of cathode chemistries available, with a growing shift towards nickel-cobalt-manganese (NCM) and nickel-cobalt-aluminium (NCA) over chemistries that do not use nickel or cobalt. Lithium-cobalt-oxide (LCO) chemistry remains the chemistry of choice for many applications in the portable consumer electronics market, given its high-energy density.

The production of cathode precursor material for lithium-ion batteries typically requires the processing of nickel and cobalt in the form of hydrated sulphates, being $\text{NiSO}_4 \cdot 7\text{H}_2\text{O}$ (~22% Ni) and $\text{CoSO}_4 \cdot 6\text{H}_2\text{O}$ (~20% Co). In NCM chemistry, manganese compounds are also required.

Pricing

Both the nickel and cobalt markets have established trading platforms, either through the LME or Metal Bulletin. However, sulphate product pricing tends to be more opaque, due to the relatively small size of this sub-market. Sulphate pricing mechanisms are typically determined on a premium to either LME (nickel) or Metal Bulletin (cobalt), reflecting the additional cost to convert nickel and cobalt-bearing materials into high purity sulphates. These premia can often be high, but appear to vary substantially depending on the market and product quality.

The lithium-ion battery industry has not been a significant consumer of nickel and, more importantly, cobalt, but this may change in the future. As production capacity is filled, raw material costs, particularly associated with nickel and cobalt, will become more important in the total battery production cost. Cathode costs represent the largest raw materials cost in the production of lithium-ion cells. Supply of critical metals for the battery sector, particularly cobalt, will require new sources of production to keep up with growing demand from the lithium-ion battery industry.

The 2016 consensus long-term metal prices from market analysts, such as CRU International Ltd and CIBC, forecast nickel and cobalt prices to rise over coming years, finding equilibrium again at historic long-term average prices. These forecasts predict nickel LME prices to rise to US\$7.50/lb and cobalt prices to increase to US\$12.00/lb. SRK notes that the pit optimisation work was conducted using a nickel price of US\$4.00/lb.

For the design purposes of this study, long-term pricing assumptions have been adopted. Additionally, no set premia for nickel and cobalt have been assumed for the production of sulphate products, as the quantum of these premia over the longer-term is unclear. However, it is important to note that the premia represent (potentially material) upside to pricing outcomes. Further work is being undertaken with industry consultants to evaluate the long-term quantum of potential premia for sulphate products over and above metal prices.

The capital and operating costs for the processing options are summarised in the following sections. The costs have also been provided in US\$, using an exchange rate of 0.75US\$:1.00A\$.

For economic analysis, metal prices are based on the long-term average consensus price forecasts from CIBC (as at Aug 25 2017) for a range of analysts. The long-term consensus nickel price was US\$9.00/lb. However, a discount to this price has been assumed for this study and a price of US\$7.50/lb has been used to assess the economics of this Report. The long-term cobalt price was US\$14.00/lb and has been used to assess the economics of this Report. As sulphate products are being provided and typically trade at a premium, assuming long term LME and LMB prices for nickel and cobalt respectively is considered to be conservative.

Capital and Operating Costs

A capital cost estimate for the design and construction of a 2.5 Mtpa HPAL processing plant incorporating RIP processing was developed in-house by Clean TeQ at a PFS level of accuracy. It was based on the earlier 2005 Study capital cost estimate completed for the Clean TeQ Sunrise Project by SNC-Lavalin (Australia) and JGC Corporation (Japan). These costs were adjusted based on the review and further modifications made, largely the inclusion of a RIP circuit, nickel and cobalt sulphate refinery, road upgrade allowance and adjustments to other areas, based on the changes associated with the modified flowsheet.

A DFS has now been initiated to develop the full plant costs from first principles, but as an interim measure, to further improve the confidence in the capital costs, Clean TeQ has further developed the RIP plant costs from first principles and has engaged Simulus Engineers to develop the refinery capital costs to better reflect the downstream processing circuits, i.e. post Ni/Co RIP, to a PFS level of accuracy. These costs have been built up using mechanical equipment costs, material take-offs for civil and structural steelwork, piping and valves, electrical load list from the mechanical equipment, with other engineering discipline costs such as instrumentation and control factored.

The HPAL section of the plant represents the largest cost centre. However, the use of RIP for nickel and cobalt recovery significantly reduces the size of downstream operations and the associated capital costs. The capital cost is estimated at A\$1,045M, based on the updated PFS cost estimates. Costs were based on an engineer-procure-construct-manage (“EPCM”) basis, incorporating a 15% contingency and are considered to be within the ± 25% accuracy band expected of a PFS level of study accuracy (the previous PFS used a 10% contingency). The base date of the cost estimate is Q3 2017 and excludes the scandium recovery and purification circuits.

Table 1-10: Capital cost estimate summary - 2.5 Mtpa

<u>Plant Area</u>	<u>Cost</u>	
	US\$	A\$
Mining	14	18
Site Preparation	11	15
Process Plant	210	280
Process Utilities	85	113
Services	110	146
Infrastructure	45	60
Total Directs	474	632
Indirects, including EPCM	105	140

Owners Costs, including spares and first fills	103	137
Capital Cost, excluding contingency	682	909
Contingency (15% of Directs/ Indirects) Less Duty	102	136
Total Capital Cost Estimate	784	1,045

The capital cost estimate excludes a number of supporting infrastructure costs. These are expected to be provided on a BOO basis or direct supply cost, and are not incorporated into the capital cost estimate. The following exclusions are noted:

- Mining operation including fleet, buildings and workshops
- Limestone from owner's quarry based on a per tonne supply cost
- Supply of all reagents, including sulphur port and rail facilities
- Liquid nitrogen plant
- Mobile plant and equipment required for operations
- Site mobile vehicles plant
- Natural gas pipeline.

Re-engagement and initial discussions have been held with a number of the key third party providers; however, the technical details and commercial terms have not been finalised, largely due to the level of study currently being undertaken. In most cases, this leverages the engineering work currently undertaken during the 2005 Study. Firmer pricing will be developed during the next phase of study as part of more formalised negotiations.

Clean TeQ developed operating cost estimates to support the PFS, based largely on the work undertaken during the 2005 Study. The estimates were originally built up from first principles. Input values were updated to reflect new contract mining, reagent, utility prices and labour costs. The stated accuracy of the estimate is reported to be within $\pm 20\%$ as at Q4 2016. The claimed accuracy range is consistent with PFS guidelines.

The operating cost establishes the Clean TeQ Sunrise Project as potentially one of the lowest cost nickel producers on the market, especially after considering the by-product cobalt credits. As the Clean TeQ Sunrise Project has a relatively high proportion of cobalt compared to other laterites, the total cost of nickel production is relatively low. No scandium by-product credits have been assumed in the base case.

The annual operating costs for the Clean TeQ Sunrise Project over the first 20 years of operation are summarised in Table 1-. The costs are based on Years 3 - 20 as tonnage is still ramping up in Years 1 and 2. The operating cost includes mining, processing, production and logistics to offtake customers. An exchange rate of US\$0.75:1.00A\$ was assumed.

Table 1-11: Operating cost summary (Years 3 - 20) – excluding transport

Cost centre	Total cost (A\$M)	Total cost (%)	Unit cost (A\$/t ore)	Unit cost (US\$/lb Ni)	Unit cost (US\$/lb Ni) after Co credits
Mining	39.6	20.7	15.86	0.72	
Processing	142.3	74.2	56.90	2.58	
Utilities	0.1	0.1	0.03	0.00	
Services & Infrastructure	0.8	0.5	0.34	0.02	
Finance & Admin	8.9	4.6	3.56	0.16	
Total	191.7	100	76.69	3.48	1.42

Project valuation

Project valuation has been completed using the discounted cash flow methodology. A cash flow model was constructed for the three options, based on inputs from the technical model/ mass balance and the engineering estimate completed by SNC- Lavalin in 2005 and Clean TeQ for RIP.

The Clean TeQ Sunrise Project considers a 21-year project life, with Years -1, -2 and -3 as the construction period, and metal production occurring between Years 1 and 20. The model development is based on an estimate of the real cost of operations and therefore excludes any allowance for inflation.

The key inputs and assumptions are presented in Table 1-

Table 1-12: Clean TeQ Sunrise Project valuation model key inputs

Autoclave Throughput	tpa	2,500,000
Average Production (20-year average)		
Nickel Sulphate (NiSO ₄ .6H ₂ O)	tpa	82,469
Cobalt Sulphate (CoSO ₄ .7H ₂ O)	tpa	15,168
Recovery (20-year average)		
Ni	%	94.2%
Co	%	93.0%
Life of Mine	years	39
Nickel Long-term Price	US\$/lb	7.50
Cobalt Long-term Price	US\$/lb	14.00
Exchange Rate (A\$: US\$) – Life of Mine	1 : n	0.75

Discount Rate	%	8%
Tax Rate	%	27.5%
Royalties		
NSW Government	%	4%
Ivanhoe Mines (after Govt royalty)	% of Revenue	2.5%
Depreciation	%	20% declining balance
Sustaining Capital (all years)	% of Directs	1.25%
Plant Financing Strategy	-	100% Equity

Discounted cash flow analysis

Table 1-13 summarises the discounted cash flow valuation for the Clean TeQ Sunrise Project for the LOM.

Table 1-13: Discounted cash flow valuation

NPV (post-tax)	A\$M	996.7
	US\$M	747.5
IRR (post-tax)	%	21.0

A sensitivity analysis was run for – feed grade, nickel price and payability have the most significant impact on the economics of the Clean TeQ Sunrise Project.

RISK FACTORS

An investment in the Ordinary Shares should be considered highly speculative due to the nature of the Company’s business and its earlier stage of development. Investments in mineral exploration and development issuers, such as the Company, involve a significant degree of risk. The exploration and development of the Clean TeQ Sunrise Project is highly speculative, characterized by significant inherent risk and may not be successful. Metal prices are also subject to significant volatility, which affects the economic viability of the Clean TeQ Sunrise Project. Anyone investing in the Company must rely on the ability, expertise, judgement, discretion, integrity and good faith of the management of the Company. There is no guarantee that Clean TeQ will be able to secure financing to meet the future development needs of its mineral projects.

The risks and uncertainties described below are not the only risks and uncertainties that the Company faces. Additional risks and uncertainties of which the Company is not aware or that the Company currently believes to be immaterial may also adversely affect the Company’s business, financial condition, results of operations or prospects. If any of the possible events described below occur, the

Company's business, financial condition, results of operations or prospects could be materially and adversely affected.

This AIF also contains forward-looking statements that involve risks and uncertainties. The Company's actual results may differ materially from those anticipated in these forward-looking statements as a result of various factors, including the risks described below and elsewhere in this AIF. See "*Forward Looking Statements*".

Dependence on the Clean TeQ Sunrise Project

Clean TeQ is primarily focused on the exploration and development of the Clean TeQ Sunrise Project. The Company does not have identified mineral reserves or resources other than those identified at the Clean TeQ Sunrise Project. Unless Clean TeQ acquires additional property interests, any adverse developments affecting the Clean TeQ Sunrise Project could have a material adverse effect upon Clean TeQ and would materially and adversely affect the potential mineral resource production, profitability, financial performance and results of operations of Clean TeQ.

The Company has not yet achieved profitable operations

As at June 30, 2017, Clean TeQ had accumulated losses of A\$12,184,000 and available cash reserves of A\$88.86 million. During the fiscal year ended June 30, 2017, the Company generated no revenues from the sale of production from its operations.

The Company will consider various forms of funding including the sale of mineral property interests, equity issuance and/or debt issuance should operating cash flows be insufficient to meet the liquidity needs of the Company.

Mineral resources and mineral reserves disclosed by the Company are only estimates

The Company has included mineral resource and reserve estimates that have been made in accordance with CIM Standards. These mineral resource estimates are classified as "Measured Mineral Resources", "Indicated Mineral Resources" and "Inferred Mineral Resources". Investors are cautioned not to assume that any part or all of those mineral deposits classified as "Measured Mineral Resources" or "Indicated Mineral Resources" will ever be converted into ore reserves. Further, "Inferred Mineral Resources" have a great amount of uncertainty as to their existence and economic feasibility. It cannot be assumed that all or any part of an Inferred Mineral Resource will ever be upgraded to a higher category. Under Canadian rules, estimates of Inferred Mineral Resources may not form the basis of feasibility or prefeasibility studies, except in rare cases. Investors are cautioned not to assume that part or all of an Indicated Mineral Resource or Inferred Mineral Resource exists, or is economically or legally mineable.

In addition, the quantities of minerals ultimately mined may differ from that indicated by drilling results. There can be no assurance that results of laboratory tests will be duplicated under on-site conditions or in production-scale operations. In the event that minerals are present in lower amounts than expected or the product mined is of a lower quality than expected, the demand for, and realizable price of, the Company's products may decrease. Short term factors relating to reserves, such as the need for orderly development of mines or the processing of new or different quality material, may also materially and adversely affect the Company's business and results of operations.

The Company may not be able to maintain an adequate and timely supply of gas, electricity, water, auxiliary materials, equipment, spare parts and other critical supplies at reasonable prices or at all

Cost effective operation of the Clean TeQ Sunrise Project depends, among other things, on the adequate and timely supply of electricity, water and auxiliary materials. Major auxiliary materials used in the Company's production include chemical products, explosives, lubricating oil, electric wires and cables, rubber products and fuel. The Company sources its auxiliary materials from domestic suppliers and its equipment from suppliers in Australia and other countries. If the Company's supply of auxiliary materials, equipment or spare parts is interrupted or their prices increase, or the Company's existing

suppliers cease to supply the Company on acceptable terms, its business, financial condition and results of operations could be materially and adversely affected.

Electricity and water are the main utilities used at the Company's Clean TeQ Sunrise Project. Because the Clean TeQ Sunrise Project is situated in a remote location in Australia, the Company faces a risk of an interruption or shortage in the Company's electricity supply, which could materially and adversely affect the Company's production. The production of electricity by the Company is mainly fueled by gas provided by and transported by third parties. Any failure to receive gas from third party suppliers will impact the volume and cost of electricity generated. Any increase in the prices of gas, diesel or water could also materially and adversely affect the Company's financial condition and results of operations.

The price of commodities greatly affects the value of the Company and the ability of the Company to develop its properties

The Company's operating results and financial condition depend upon the market prices of metals, which are cyclical and which can fluctuate widely with demand for its metals. Demand is affected by numerous factors beyond its control, including the overall state of the economy, general level of industrial production, interest rates, rate of inflation, foreign exchange rates and investment demand for commodities. Such external economic factors are in turn influenced by changes in international investment patterns, monetary systems and political developments.

Future price declines may, depending on hedging practices, materially reduce our profitability and could cause the Company to reduce output at its operations, all of which could reduce its cash flow from operations resulting in liquidity pressure.

The Company has and will rely on a limited number of customers for the purchase of the majority of its production, and currently has only one committed customer

Clean TeQ has entered into an offtake contract providing for the sale to a single purchaser of fixed tonnages representing 20% of its future estimated nickel and cobalt product for a 5 year period, and which may be extended for up to life of mine in some circumstances. If Clean TeQ is not able to find additional purchasers, whether through committed offtake contracts or otherwise, for the remaining majority of its nickel and cobalt production from the Clean TeQ Sunrise Project, that may materially and adversely impact the development of the Clean TeQ Sunrise Project and the Company's financial results and performance. If, once contractually committed, a purchaser breaches or otherwise fails to honor its contractual offtake commitments, any such breach may materially and adversely impact the Company's financial results and performance. Clean TeQ may not be able to find alternative purchasers for its nickel and cobalt production. In addition, costs of future litigation or arbitral hearings could be protracted and costly, and may not be favorably decided in favour of Clean TeQ.

The Company has limited history as a mineral production company

The Company has been in existence since 1989 and it has not yet generated revenues from mineral production. The Company's success will depend largely upon its ability to develop the Clean TeQ Sunrise Project and additional commercially viable mineral reserves, which may never happen. In addition, putting an additional mining project into production requires substantial planning and expenditures. As a result of these factors, it is difficult to evaluate the Company's prospects, and the Company's future success is more uncertain than if it had a longer or more proven history.

The capital cost of the HPAL processing plant may be higher than estimated

The capital cost estimates of the Company's HPAL processing plant in the current PFS exclude a number of supporting infrastructure costs, which are expected to be provided on a BOO basis or as direct supply costs. There is also potential for the HPAL processing plant capital cost to increase as further detailed engineering is undertaken, due to changing scope, escalation in prices or due to other factors affecting capital cost estimates. As a result, the actual capital cost of the HPAL and the supporting infrastructure

may be higher than currently estimated, which may adversely affect the Company's future financial condition and results of operations.

The operating cost of the HPAL processing plant and supporting infrastructure and utilities may be higher than estimated

The operating cost estimates of the Company's HPAL processing plant in the current PFS include a number of supporting reagent and utilities costs that are expected to be provided on a BOO basis. Until firm pricing for these costs has been provided, and the HPAL cost inputs finalised with the ultimate design and costs, the actual operating cost of the HPAL and the supporting infrastructure may be higher than currently estimated, which may adversely affect the Company's future financial condition and results of operations.

The Company may need to source additional raw water supply

The bulk of the raw water demand will be sourced from the Clean TeQ Sunrise Project's borefield 65 km south of the mine which is licenced for an abstraction rate of 3.2 GL/annum. This amount covers water requirements in terms of potable water, fire water, high pressure hose-down water, mine utility water and plant water for use in the process, as well as feed to the water treatment plant producing high purity water for steam production. It is possible that a supplementary water source will be required for the Clean TeQ Sunrise Project in the future. Alternative sources of supply may need to be considered if the appropriate approvals are not obtained by the Company.

Title Risk

Although the Company has taken steps to verify title to the mineral properties in which it has an interest, these procedures do not guarantee the Company's title to those mineral properties. Such properties may be subject to prior agreements or transfers and title may be affected by undetected defects.

Furthermore, the Company could lose title to its tenements if tenement conditions are not met or if insufficient funds are available to meet expenditure commitments as and when they arise. The Company regularly has tenements up for renewal. There is no assurance that these renewals will be granted. If a tenement is not granted or renewed, the Company may suffer significant damage through loss of the opportunity to discover and develop any mineral resource on that tenement.

Operational Risks

The Company's operations are subject to all of the risks normally incident to the exploration for and the development and operation of mineral properties. The Company has environmental obligations at its properties, including the Clean TeQ Sunrise Project, and has implemented comprehensive safety and environmental measures designed to comply with or exceed government regulations and ensure safe, reliable and efficient operations during all phases of its operations. Nevertheless, mineral exploration and exploitation involves a high degree of risk, which even a combination of experience, knowledge and careful evaluation may not be able to overcome. Unusual or unexpected formations, formation pressures, fires, power outages, labor disruptions, flooding, explosions, tailings impoundment failures, cave-ins, landslides and the inability to obtain adequate machinery, equipment or labor are some of the risks involved in mineral exploration and exploitation activities. The Company's assumed environmental obligations may exceed the current forecasts, as may any contractual commitments of the Company in respect of any of its projects and/or business activities.

Production companies face additional risks including the risk of unexpected maintenance or technical problems, periodic interruptions to their mining operations due to inclement or hazardous weather conditions and natural disasters, industrial accidents, power or fuel supply interruptions and critical equipment failure, including malfunction and breakdown of machinery which would require considerable time to replace. These risks and hazards may result in personal injury, damage to, or destruction of, properties or production facilities, environmental damage, business interruption and damage to its business reputation. In addition, breakdowns of equipment, difficulties or delays in obtaining replacement

equipment, natural disasters, industrial accidents or other causes could temporarily disrupt the Company's operations, which in turn may also materially and adversely affect its business, prospects, financial condition and results of operations.

There is no assurance that the Company will be able to generate funds from operations or to obtain sufficient financing in the future on terms acceptable to it. The ability of the Company to arrange additional financing will depend, in part, on prevailing capital market conditions as well as the business performance of the Company. Failure to obtain additional financing on a timely basis may cause the Company to postpone, abandon, reduce or terminate its operations and could have a material adverse effect on the Company's future business, results of operations and financial condition. Any additional equity financing may be dilutive to investors, and debt financing, if available, may involve restrictions on future financing and operating activities.

There is no assurance that the Company will be able to acquire additional suitable mineral properties in the future

There is no assurance that the Company will be able to acquire other mineral properties of merit, whether by way of option, joint venture or otherwise, should the Company wish to acquire any tenements or properties in the future in addition to its current holdings.

Changes to environmental regulatory requirements could significantly increase the Company's costs

Clean TeQ must comply with stringent environmental legislation in carrying out work on the Clean TeQ Sunrise Project. Environmental legislation is evolving in a manner that may require stricter standards and enforcement, increased fines and penalties for non-compliance, more stringent environmental assessments of its proposed projects and a heightened degree of responsibility for companies and their officers, directors and employees. Changes in environmental legislation could prevent, delay and/or increase the cost of exploration and development of the Clean TeQ Sunrise Project.

Changes in government regulations may affect the Company's development of the Clean TeQ Sunrise Project

Government regulations relating to mineral rights tenure, environmental approval requirements, permission to disturb areas involving native title and the right to operate and the imposition of increased or further taxes may adversely affect the financial performance of Clean TeQ. The Company may not be able to obtain all necessary licenses and permits that may be required to carry out exploration at its properties. Obtaining the necessary governmental permits is a complex, time consuming and costly process. The duration and success of efforts to obtain permits are contingent upon many variables that are outside the Company's control. There can be no assurance that all necessary approvals and permits will be obtained and, if obtained, that the costs involved will not exceed the Company's prior estimates. It is possible that the costs and delays associated with the compliance with such standards and regulations could become such that the Company would not proceed with the further development of its properties. Additionally, the imposition of increased or further taxes may negatively impact the cost of the Company's operations.

The Company's inability to protect its intellectual property could have a material adverse effect on its business

Clean TeQ uses its proprietary Clean-iX technology for the extraction and purification of metals. The base technology for the Clean-iX process is held by CleanTeQ under a licence with ARRICT. Since obtaining the licence, Clean TeQ has further developed the technology for base metals, uranium and gold, with particular improvements in relation to laterite ore processing, scandium and uranium. Clean TeQ has been granted 10 additional patents on various aspects of the technology, including one for extraction and purification of scandium.

Clean TeQ's success and competitive position are dependent in part upon its proprietary intellectual property. Clean TeQ relies on a combination of patents and trade secrets to protect such intellectual

property, and it expects to continue to do so. Although Clean TeQ seeks to protect its proprietary rights through a variety of means, it cannot guarantee that the protective steps they have taken are adequate to protect these rights. Patents issued to or licensed by Clean TeQ in the past or in the future may be challenged and held invalid. In addition, as the Company's patents expire, it may be unsuccessful in extending their protection through patent term extensions. The expiration of, or the failure to maintain or extend the patents, could have a material adverse effect on the Company.

The Company may spend significant resources to enforce its intellectual property rights and such enforcement could result in litigation. Intellectual property litigation is complex and can be expensive and time-consuming. However, the Company's efforts in this regard may not be successful. The Company also may not be able to detect infringement.

The invalidation of key intellectual property rights or an unsuccessful outcome in lawsuits filed to protect the Company's intellectual property could have a material adverse effect on its financial condition, results of operations or prospects.

Clean TeQ may be subject to challenges by third parties regarding its intellectual property, including, among others, claims regarding validity, enforceability, scope and effective term. The Company may in the future be forced to defend against claims and legal actions alleging infringement of the intellectual property rights of others, and such intellectual property litigation is typically costly and time-consuming. Adverse determinations in any such litigation could result in significant liabilities to third parties or injunctions, or could require the Company to seek licenses from third parties and, if such licenses are not available on commercially reasonable terms, prevent the Company from using its intellectual property, which could have a material adverse effect on the Company.

The Company's business is affected by fluctuations in currency exchange rates

Revenues from the sale of mineral products are primarily transacted in US dollars. Costs incurred by the Company are primarily in Australian currency. The Clean TeQ Sunrise Project operations are located in Australia and most of the property related expenditures, production expenditures and exploration and development costs are denominated in Australian dollars. Movements in exchange rates may have a material impact on the Company's Australian dollar cash balances and reported earnings.

Conflicts of interest may arise and may not be disclosed and dealt with appropriately by certain directors and officers of the Company

Certain directors and officers of the Company are, or may become, associated with other natural resource companies that may give rise to conflicts of interest. In accordance with the Australian Corporations Act, directors, who have a material personal interest in a matter that relates to the affairs of the Company, including a material interest in any person who is a party to a material contract or a proposed material contract with the Company, are required, subject to certain exceptions, to disclose that interest and generally abstain from voting on any resolution to approve the matter. In addition, directors and officers are required to act honestly and in good faith with a view to the best interests of the Company.

The Company is subject to risks applicable to joint ventures

The Company has certain joint venture relationships with third parties. Failure of the Company's joint venture partners to meet their contractual obligations and commitments to the Company or to third parties could have a material adverse effect on the Company.

Potential future acquisitions or investments in other companies may have a negative impact on the Company's business.

Clean TeQ may seek to expand its business through acquisitions as it intends to consider and evaluate opportunities for growth through acquisitions when suitable acquisition targets present themselves; however, there can be no assurance that the Company will find attractive acquisition candidates in the

future, or that Clean TeQ will be able to acquire such candidates on economically acceptable terms, if at all. Acquisitions may require substantial capital and negotiations of potential acquisitions and the integration of acquired operations could disrupt the Company's business by diverting management, and employees' attention away from day-to-day operations. The difficulties of integration may be increased by the necessity of coordinating geographically diverse organizations, integrating personnel with disparate backgrounds and combining different corporate cultures.

At times, acquisition candidates may have liabilities or adverse operating issues that the Company fails to discover through due diligence prior to the acquisition. If the Company consummates any future acquisitions, the Company's capitalization, and results of operations may change significantly.

Any acquisition involves potential risks, including, among other things: (i) mistaken assumptions about mineral properties, mineral resources or mineral reserves and costs, including synergies; (ii) an inability to successfully integrate any operation Clean TeQ acquires; (iii) an inability to hire, train or retain qualified personnel to manage and operate the operations acquired; (iv) the assumption of unknown liabilities; (v) limitations on rights to indemnity from the seller; (vi) mistaken assumptions about the overall cost of equity or debt; (vii) unforeseen difficulties operating acquired projects, which may be in new geographic areas; and (viii) the loss of key employees and/or key relationships at the acquired project.

Acquisitions or investments may require the Company to expend significant amounts of cash, resulting in the Company's inability to use these funds for other business purposes. The potential impairment or complete write-off of goodwill and other intangible assets related to any such acquisition may reduce the Company's overall earnings and could negatively affect the Company's balance sheet.

The occurrence of any of the foregoing could have a material adverse effect on Clean TeQ's business, financial condition, results of operations or prospects.

Cyber Security Risk

The Company has become increasingly dependent upon the development and maintenance of information technology systems that support the general operating aspects of the business. Exposure of the Company's information technology infrastructure to external threats poses a risk to the security of these systems. Such cyber security threats include unauthorized access to information technology systems due to hacking, viruses and other deliberate or inadvertent causes that can result in service disruptions, system failures and the disclosure of confidential business information.

The Company applies risk management controls in line with industry accepted standards to protect its information assets and systems; however, these controls may not adequately protect against cyber security breaches. There is no assurance that the Company will not suffer losses associated with cyber security breaches in the future, including with respect to negative effects on the Company's operational performance and earnings, the incurrence of regulatory penalties, reputational damage and costs required to investigate, mitigate and remediate any potential vulnerabilities.

Clean TeQ's insurance coverage does not cover all of its potential losses, liabilities and damages related to its business and certain risks are uninsured or uninsurable

The Company's business is subject to a number of risks and hazards (as further described herein). Although the Company maintains insurance to protect against certain risks in such amounts as it considers to be reasonable, its insurance will not cover all the potential risks associated with its activities, including any future mining operations. The Company may also be unable to maintain insurance to cover its risks at economically feasible premiums, or at all. Insurance coverage may not continue to be available or may not be adequate to cover any resulting liability. Moreover, insurance against risks such as environmental pollution or other hazards as a result of exploration or production may not be available to the Company on acceptable terms. The Company might also become subject to liability for pollution or other hazards

which it is not currently insured against and/or in future may not insure against because of premium costs or other reasons. Losses from these events may cause the Company to incur significant costs which could have a material adverse effect on Clean TeQ's business, financial condition, results of operations or prospects.

It may not be possible to effect service of process and enforce judgments outside of Canada

A number of the Company's subsidiaries are incorporated or otherwise organized under the laws of foreign jurisdictions and a number of the directors and officers of the Company and the experts named in this AIF reside outside Canada. In addition, some or all of the assets of those persons and the Company and its subsidiaries are located outside of Canada. It may not be possible for claimants to collect from or enforce judgements obtained in courts in Canada predicated on the civil liability provisions of securities legislation against the Company's assets, its directors and officers and certain of the experts named in this AIF. Moreover, it may not be possible for shareholders to effect service of process within Canada upon the directors, officers and experts referred to above.

Competition in the mining industry may adversely affect the Company

The mining industry is intensely competitive. The Company competes with other mining companies, many of which have greater resources and experience. Competition in the mining industry is primarily for: (i) properties which can be developed and can produce economically; (ii) the technical expertise to find, develop, and operate such properties; (iii) labour to operate the properties; and (iv) capital to fund such properties. Such competition may result in the Company being unable to acquire desired properties, to recruit or retain qualified employees or to acquire the capital necessary to fund its operations and develop its properties. The Company's inability to compete with other mining companies for these resources could have a material adverse effect on Clean TeQ's business, financial condition, results of operations or prospects.

Many competitors not only explore for and mine minerals, but conduct refining and marketing operations on a worldwide basis. The Company may compete with such mining companies in refining and marketing its products to international markets. Any inability to compete with established competitors could have a material adverse effect on Clean TeQ's business, financial condition, results of operations or prospects.

Clean TeQ is dependent on qualified personnel

The Company's business is dependent on retaining the services of its key management personnel with a variety of skills and experience, including in relation to the development and operation of mineral projects. The success of the Company is, and will continue to be, dependent to a significant extent on the expertise and experience of its directors and senior management. Clean TeQ does not have in place formal programs for succession and training of management. Failure to retain, or loss of, one or more of these people could have a material adverse effect on the Company's business, financial condition, results of operations or prospects. The Company's success will also depend to a significant degree upon the contributions of qualified technical personnel and the Company's ability to attract and retain highly skilled personnel. Competition for such personnel is intense, and the Company may not be successful in attracting and retaining qualified personnel. Its inability to attract and retain these people could have a material adverse effect on Clean TeQ's business, financial condition, results of operations or prospects.

The Company is reliant on the continuous and uninterrupted operations of its information technology ("IT") systems

Security of its IT systems are critical elements to the operations of the Company and its mineral projects. Protection against cyber security attacks, including cloud security and security of all of the Company's IT systems (and related electronically stored data), are undertaken by the Company. Any cyber security attacks and/or any failure in IT systems to prevent unauthorized access or availability to, the Company's IT systems could result in disruptions to the Clean TeQ Sunrise Project operations, the inability of Company personnel to access such systems, legal liability, and could result in the loss of the

business data, personal information or financial information. The Company stores all of its proprietary data on servers including, but not limited to, financial records, drilling databases, technical information, legal information, licences and human resource records. The Company utilizes standard and best practice protocols and procedures in protecting and backing up electronic records; however, there is no assurance that third parties will not illegally access these records which could have a material adverse effect on the Company. Any such attack or loss could adversely affect the reputation, operations or financial performance of the Company, and could result in unforeseen costs to defend against such attacks or remedy any losses.

Mining operations are subject to laws and regulations relating to the protection and remediation of the environment

The Company's future mining operations and exploration activities are subject to laws and regulations relating to the protection and remediation of the environment. These laws, regulations and the governmental policies for implementation of such laws and regulations are constantly changing and are generally becoming more restrictive. The costs associated with compliance with these laws and regulations are substantial and possible future laws and regulations and changes to existing laws and regulations (including the imposition of higher taxes and mining royalties) could cause additional expense or capital expenditure, or result in restrictions or delays in the Company's development plans.

The Company cannot give any assurance that, notwithstanding its precautions, breaches of environmental laws, whether inadvertent or not, or environmental pollution, will not occur. A breach of environmental laws and regulations may allow governmental authorities and third parties, who have an interest in any future mining operations or the consequences of mining operations, to bring lawsuits based upon damages to property and injury to persons resulting from the environmental impact of the Company's potential future operations which could lead to the imposition of substantial fines, penalties or other civil or criminal sanctions and could have a material adverse effect on the Company's business, financial condition, results of operations or prospects.

If the Company's environmental compliance obligations were to vary as a result of changes to the legislation, if certain assumptions it makes to estimate liabilities are incorrect, or if unanticipated conditions were to arise in its operations, the Company's expenses and other obligations could increase, which could have a material adverse effect on the Company's business, financial condition, results of operations or prospects.

As a participant in the resource extraction industry, the Company may face opposition from local and international groups

There is an increasing level of public concern relating to the effects of mining production on its surroundings, communities and environment. Certain non-governmental organizations, public interest groups and reporting organizations ("NGOs"), who oppose globalization and resource development and who may not be bound to codes of ethical reporting, can be vocal critics of the mining industry. In addition, there have been many instances in which local community groups have opposed resource extraction activities, which have resulted in disruption and delays to the relevant operation. While the Company seeks to operate in a socially responsible manner, NGOs or local community organizations could direct adverse publicity and/or disrupt the operations of the Company in respect of one or more of its properties, regardless of its successful compliance with social and environmental best practices, due to political factors, activities of unrelated third parties on lands in which the Company has an interest or the Company's operations specifically. Any such actions and the resulting media coverage could have an adverse effect on the reputation and financial condition of the Company or its relationships with the communities in which it operates, which could have a material adverse effect on the Company's business, financial condition, results of operations or prospects.

The costs of complying with applicable laws and governmental regulations may have an adverse impact on the Company's business

The Company's operations and exploration activities are subject to laws and regulations governing various matters. These include laws and regulations relating to repatriation of capital and exchange controls, taxation, labour standards and occupational health and safety and historic and cultural preservation.

In particular, mining operations are subject to a variety of industry specific health and safety laws and regulations. These laws and regulations are formulated to improve and to protect the safety and health of employees. They have limited, if any, application to the Company while it remains in the exploration stage, except to the extent that they may impact the scope and costs of refurbishment of the existing infrastructure at the Clean TeQ Sunrise Project. Should compliance with standards require a material increase in future expenditure, it could have a material adverse effect on the Company's business, financial condition, results of operations or prospects.

Amendments to current laws, regulations and permits governing operations and activities of mining companies, or the more stringent enforcement thereof, could have a material adverse effect on the Company's business, financial condition, results of operations or prospects by increasing exploration expenses, future capital expenditures or future production costs or by reducing the future level of production, or cause the abandonment of or delays in the development of the Clean TeQ Sunrise Project.

The Company's internal controls and procedures may not be sufficient to ensure compliance with anti-bribery and anti-corruption laws

The Company's activities are subject to a number of laws that prohibit various forms of corruption, including local laws that prohibit both commercial and official bribery and anti-bribery laws that have jurisdiction over the Company, its subsidiaries and/or any of its directors, officers, employees or other personnel, such as the Corruption of Foreign Public Officials Act (Canada), the Foreign Corrupt Practices Act of 1997 (United States), as each may be amended from time to time (collectively, the "Acts").

While the Acts are not identical, the Acts generally make it illegal for an employee or other person acting on the Company's behalf, in order to obtain or retain business, directly or indirectly, to offer or agree to give or offer loans, rewards, payments or benefits of any kind to foreign public officials or to any person for the benefit of public officials. Foreign public officials include persons holding legislative, administrative or judicial positions with a foreign state (including political divisions within a foreign state), persons who perform public duties or functions for a foreign state (such as persons employed by boards, commissions or government-owned or -controlled companies), officials and agents of international organizations, foreign political parties and candidates for office.

The increasing number and severity of enforcement actions in recent years presents particular risks with respect to the Company's business activities, including the potential for severe legal penalties if any employee or other person acting on the Company's behalf might offer, authorize, or make an illegal payment to a foreign public official, party official, candidate for political office, or political party, an employee of a foreign state-owned or state-controlled enterprise, or an employee of a public international organization.

The Company has an anti-corruption policy, an anti-fraud policy, internal controls and procedures intended to address compliance and business integrity issues, and the Company trains its employees on anti-bribery compliance. However, despite careful establishment and implementation there can be no assurance that these or other anti-bribery, anti-fraud or anti-corruption policies and procedures are or will be sufficient to protect against fraudulent and/or corrupt activity. In particular, the Company, in spite of its best efforts, may not always be able to prevent or detect corrupt or unethical practices by employees or third parties, such as sub-contractors or joint venture partners, which may result in reputational damage, civil and/or criminal liability (under the Acts or any other relevant compliance, anti-bribery, anti-fraud or

anti-corruption laws) being imposed on the Company, which could have a material adverse effect on the Company's business, financial condition, results of operations or prospects.

Mining is inherently dangerous and subject to factors or events beyond the Company's control

The Company's current business, and any future development or mining operations, involve various types of risks and hazards typical of companies engaged in the mining industry. These risks affect the current exploration, development and refurbishment activities of the Company, and will affect the Company's business to an even larger extent once commercial mining operations, if any, commence. Such risks include, but are not limited to: (i) industrial accidents; (ii) unusual or unexpected rock formations; (iii) structural cave-ins or slides and pitfall, ground or slope failures and accidental release of water from surface storage facilities; (iv) fire, flooding and earthquakes; (v) rock bursts; (vi) metals losses; (vii) periodic interruptions due to inclement or hazardous weather conditions; (viii) environmental hazards; (ix) discharge of pollutants or hazardous materials; (x) failure of processing and mechanical equipment and other performance problems; (xi) geotechnical risks, including the stability of the underground hanging walls and unusual and unexpected geological conditions; (xii) unanticipated variations in grade and other geological problems, water, surface or underground conditions; (xiii) labour disputes or slowdowns; (xiv) work force health issues as a result of working conditions; and (xv) force majeure events, or other unfavourable operating conditions.

These risks, conditions and events could result in: (i) damage to, or destruction of, the value of, the Clean TeQ Sunrise Project or their facilities; (ii) personal injury or death; (iii) environmental damage to the Clean TeQ Sunrise Project or the properties of others; (iv) delays or prohibitions on mining or the transportation of minerals; (v) monetary losses; and (vi) potential legal liability and any of the foregoing could have a material adverse effect on the Company's business, financial condition, results of operation or prospects. In particular, underground refurbishment and exploration activities present inherent risks of injury to people and damage to equipment. Significant mine accidents could occur, potentially resulting in a complete shutdown of the Company's operations at the Clean TeQ Sunrise Project which could have a material adverse effect on the Company's business, financial condition, results of operations or prospects.

DIVIDENDS AND DISTRIBUTIONS

The Company has never declared or paid a dividend. The Board intends to retain future earnings for reinvestment in the Company's business, and therefore, has no current intention to declare or pay dividends on the Ordinary Shares in the foreseeable future. The Company's dividend policy will be reviewed from time to time in the context of its earnings, financial condition and other relevant factors. There can be no assurance that the Company will generate sufficient earnings or cash flow to allow it to pay dividends.

DESCRIPTION OF CAPITAL STOCK

Subject to certain prescribed exceptions under the Australian Corporations Act and the Company's constitution, the Company is authorized to issue an unlimited number of Ordinary Shares. The following is a summary of the Company's capital stock. It does not purport to be complete and is subject to, and is qualified in its entirety by reference to the applicable provisions of Australian corporate law and the Company's constitution. As at November 30, 2017, 579,950,182 Ordinary Shares are issued and outstanding.

Ordinary Shares

Holders of Ordinary Shares are entitled to receive notice of any shareholder meetings, and to attend and cast one vote per Ordinary Share at all such meetings. Holders of Ordinary Shares do not have cumulative voting rights with respect to the election of directors and, accordingly, holders of a majority of the Ordinary Shares entitled to vote in any election of directors may elect all directors standing for

election. Holders of Ordinary Shares are entitled to receive on a pro rata basis such dividends, if any, as and when declared by the Board at its discretion from funds legally available therefore and upon the liquidation, dissolution or winding-up of the Company are entitled to receive on a pro rata basis the net assets of the Company after payment of debts and other liabilities, in each case subject to the rights, privileges, restrictions and conditions attaching to any other series or class of shares ranking senior in priority to or on a pro rata basis with the Ordinary Shares with respect to dividends or liquidation. The Ordinary Shares do not carry any pre-emptive, subscription, redemption or conversion rights, nor do they contain any sinking or purchase fund provisions.

Shareholder Approval

The ASX Rules provide that a company must not, subject to certain exceptions, issue during any 12 month period Ordinary Shares or other securities with rights of conversion to Ordinary Shares (such as an option) if the number of those Ordinary Shares exceeds 15% of the total Ordinary Shares on issue at the commencement of that 12 month period.

MARKET FOR SECURITIES

Market

The Ordinary Shares were listed on the ASX on November 5, 2007 under the symbol “CLQ”. The closing price of the Ordinary Shares on the ASX on November 30, 2017 was A\$1.60. On December 15, 2017, the Ordinary Shares also began trading on the TSX under the symbol “CLQ”.

Trading Price and Volume of the Ordinary Shares

The Ordinary Shares of Clean TeQ are currently listed on the ASX under the trading symbol “CLQ”. The total monthly volume of trading and the monthly intra-day price ranges of the Ordinary Shares on the ASX for the period from September 1, 2016 to October 18, 2017 are set forth in the following table.

<u>Month</u>	<u>High A\$</u>	<u>Low A\$</u>	<u>Volume</u>
October 2016	0.65	0.325	30,392,351
November 2016	0.54	0.365	21,573,947
December 2016	0.59	0.47	15,776,105
January 2017	0.65	0.45	16,427,042
February 2017	1.02	0.645	37,398,349
March 2017	1.18	0.875	53,595,909
April 2017	0.98	0.60	32,049,448
May 2017	0.80	0.60	23,661,977
June 2017	0.84	0.54	31,496,027
July 2017	0.815	0.64	19,913,679

August 2017	0.98	0.75	26,957,516
September 2017	1.15	0.94	30,581,133
October 2017	1.59	1.02	28,156,627
November 2017	1.78	1.39	50,890,027

Prior Sales

The following table sets forth certain information regarding the sale of Ordinary Shares during the period commencing 12 months prior to the date of this AIF.

Date of Issue	Number and Type of Securities	Issue Price Per Securities	Aggregate Issue Price	Nature of Consideration
November 20, 2017	108,471 Ordinary Fully Paid Shares	\$A0.5850	Nil ²	Nil
November 6, 2017	625,345 Ordinary Fully Paid Shares	\$A0.2712	Nil ²	Nil
November 6, 2017	303,756 Ordinary Fully Paid Shares	\$A0.3100	Nil ²	Nil
October 27, 2017	231,884 Ordinary Fully Paid Shares	\$A0.3010	A\$69,797.08 ³	Cash
October 23, 2017	500,000 Ordinary Fully Paid Shares	\$A0.2700	A\$135,000.00 ³	Cash
September 7, 2017	10,219 Ordinary Fully Paid Shares	\$A0.00 ¹	Nil ¹	Nil
August 29, 2017	200,751 Ordinary Fully Paid Shares	\$A0.2820	Nil ²	Nil
August 11, 2017	1,637,001 Ordinary Fully Paid Shares	\$A0.1450	\$A237,365.14 ³	Cash
July 28, 2017	66,445 Ordinary Fully Paid Shares	\$A0.3010	\$A19,999.95 ³	Cash
June 20, 2017	34,580 Ordinary Fully Paid Shares	\$A0.3010	\$A 10,408.58 ³	Cash
June 9, 2017	1,211,255 Ordinary Fully Paid Shares	\$A0.1155	\$A139,899.95 ³	Cash
June 9, 2017	2,000,000 Ordinary Fully Paid Shares	\$A0.1455	\$A291,000.00 ³	Cash
June 5, 2017	288,745 Ordinary Fully Paid Shares	\$A0.1155	\$A33,350.05 ³	Cash
May 5, 2017	100,000 Ordinary Fully Paid Shares	\$A0.2820	\$A28,200.00 ³	Cash
May 5, 2017	500,000 Ordinary Fully Paid Shares	\$A0.1155	\$A57,750.00 ³	Cash
April 21, 2017	100,000 Ordinary Fully Paid Shares	\$A0.2820	\$A28,200.00 ³	Cash
March 28, 2017	92,518,888 Ordinary Fully Paid Shares	\$A0.8800	\$A81,416,621.44 ⁴	Cash
March 23, 2017	135,251 Ordinary Fully Paid Shares	\$A0.3010	\$A40,710.55 ³	Cash
March 14, 2017	77,800 Ordinary Fully Paid Shares	\$A0.3010	\$A23,417.80 ³	Cash
March 14, 2017	500,000 Ordinary Fully Paid Shares	\$A0.2820	\$A141,000.00 ³	Cash
November 8, 2016	38,461, 539 Ordinary Fully Paid Shares	\$A0.3900	\$A15,000,000.21 ⁴	Cash

Notes:

- (1) Shares issued under Employee Tax Exempt Share Plan
- (2) Shares issued following exercise of unlisted options issued pursuant to cashless exercise facility in accordance with Employee Incentive Plan Rules
- (3) Shares issued following conversion of unlisted options
- (4) Shares issued by way of a placement to institutional shareholders

ESCROWED SECURITIES AND SECURITIES SUBJECT TO CONTRACTUAL RESTRICTION ON TRANSFER

Designation of Class	Number of securities held in escrow or that are subject to a contractual restriction on transfer	Percentage of Class
Ordinary Fully Paid Shares Escrowed to December 19, 2017	64,524	0.01%

DIRECTORS AND EXECUTIVE OFFICERS

The following table sets out the names and country and state or province of residence of the directors and executive officers of the Company, their present position(s) and offices with the Company, their principal occupations during the last five years and their holdings of Ordinary Shares, as applicable, as at the date hereof.

The term of office of the Company's executive officers expires at the discretion of the Company's directors.

Name and Municipality of Residence	Position with the Company	Principal Occupation for Past Five Years	Date of Appointment	Number of Ordinary Shares Owned Directly or Indirectly
Robert M. Friedland Singapore	Co-Chair & Non-Executive Director	Founder and Executive Chairman of Ivanhoe (November 2000 – present); Co Chairman of SK Global (March 2017 – present); Executive Chairman of the former Ivanhoe Mines Ltd. (now Turquoise Hill Resources Ltd.) (March 1994 – April 2012); Chief Executive Officer of the former Ivanhoe Mines Ltd. (now Turquoise Hill Resources Ltd.) (October 2010 – April 2012); Chairman of Ivanhoe Capital Corporation (January 1991 – present); President and Chief Executive Officer of Ivanhoe Capital Corporation (July 1988 – present); Founder and Executive Co-Chairman of Ivanhoe Energy Inc. (May 2008 – October 2014); Chief Executive Officer and Co-Chairman of High Power Exploration Inc. (December 2015 - present); Chairman of I-Pulse Inc. (April 2008 – present); Co-Chairman of Clean TeQ Holdings Limited (September 2016 – present).	September 8, 2016	94,518,888
Zhaobai Jiang China	Co-Chair & Non-Executive Director	Chairman of Shanghai Pengxin Group Co., Ltd. (April 1997 to present).f	April 24, 2017	92,518,888
Sam Riggall Australia	Managing Director and Chief Executive Officer	Chairman of Clean TeQ Holdings (4 June 2013 – 24 April 2017) Chief Executive Officer of Clean TeQ Holdings effective (1 July 2015 – 24 April 2017). Managing Director of Clean TeQ Holdings (24 April 2017 – present).	June 4, 2013	6,917,944

Eric Finlayson Australia	Non-Executive Director	President of High Power Exploration (2015 – present), Senior Advisor at High Power Exploration (2013-2015) Global Head of Exploration at Rio Tinto.	September 16, 2015	Nil
Ian Knight Australia	Non-Executive Director	Managing Director of Axsia Corporate Pty Ltd, Partner of nem Australasia Pty Ltd.	July 8, 2013	1,025,557
Mike Spreadborough Australia	Non-Executive Director	Managing Director of Nusantara Resources Limited (2016 – present), Chief Operating Officer of Sandfire Resources Limited (2013-2016), Chief Operating Officer at Ivanhoe Australia Limited (2011-2013)	December 8, 2016	Nil
Bingham Li China	Non-Executive Director	Director of the Risk Control & Legal Department of Pengxin Mining (present).	April 24, 2017	Nil
Stefanie Loader Australia	Non-Executive Director	Managing Director of Northparkes Copper and Gold Mine for CMOIC International (2014-2017).	July 1, 2017	Nil
Ben Stockdale Australia	Chief Financial Officer	Chief Financial Officer at Clean TeQ Holdings (2015 – present), Chief Financial Officer of Unity Mining Limited (2013-2015), General Manager, Finance at Tigers Realm Group (2011-2013).	January 15, 2015	75,000

As at the date of this AIF, the Company’s directors and executive officers as a group beneficially own, directly or indirectly, or exercise control or direction over an aggregate of 195,056,277 Ordinary Shares, representing 33.63% of the issued and outstanding Ordinary Shares.

Cease Trade Orders, Bankruptcies and Penalties and Sanctions

To the knowledge of management, except as disclosed herein, no director or executive officer of the Company is, as of the date of this AIF, or was, within the 10 years before the date hereof, a director, chief executive officer or chief financial officer of any company (including Clean TeQ) that was the subject of a cease trade order, an order similar to a cease trade order or an order that denied the Company access to any exemption under securities legislation that was in effect for a period of more than 30 consecutive days, that was issued (i) while such person was acting in that capacity, or (ii) after such person was acting in such capacity and which resulted from an event that occurred while that person was acting in such capacity.

To the knowledge of management, except as disclosed herein, no director or executive officer of the Company, or shareholder holding a sufficient number of securities to affect materially the control of the Company is, as of the date of this AIF, or has been, within 10 years before the date hereof, a director or executive officer of any company that, while such person was acting in that capacity, or within a year of that person ceasing to act in that capacity, became bankrupt, made a proposal under any legislation relating to bankruptcy or insolvency or was subject to or instituted any proceedings, arrangement or compromise with creditors or had a receiver, receiver manager or trustee appointed to hold its assets.

Mr. Robert Friedland served as the Executive Co-Chairman of Ivanhoe Energy Inc. (“**Ivanhoe Energy**”) from May 2008 to October 2014 and was Deputy Chairman from June 1999 to May 2008, President from May 2008 to May 2010, and Chief Executive Officer from May 2008 to December 2011. On February 20,

2015, Ivanhoe Energy filed a Notice of Intention to Make a Proposal under subsection 50.4(1) of the *Bankruptcy and Insolvency Act (Canada)*. On June 2, 2015, having failed to file a proposal, Ivanhoe Energy was assigned into bankruptcy. Cease trade orders were issued against Ivanhoe Energy in Alberta (July 15, 2015), Quebec (May 7, 2015), Manitoba (May 6, 2015), Ontario (May 4, 2015) and British Columbia (April 14, 2015) in respect of the company failing to file its audited financial statements and associated filings for the year ending December 31, 2014, which cease trade orders remain in effect as at the date of this AIF.

To the knowledge of management, no director or executive officer of the Company, or shareholder holding a sufficient number of securities to affect materially the control of the Company has, within the 10 years before the date of this AIF, become bankrupt, made a proposal under any legislation relating to bankruptcy or insolvency, or become subject to or instituted any proceedings, arrangement or compromise with creditors, or had a receiver, receiver manager or trustee appointed to hold the assets of the director, executive officer or shareholder.

To the knowledge of management, no director or executive officer of the Company, or shareholder holding a sufficient number of securities to affect materially the control of the Company has been subject to any penalties or sanctions imposed by a court relating to securities legislation or by a securities regulatory authority or has entered into a settlement agreement with a securities regulatory authority, or has been subject to any other penalties or sanctions imposed by a court or regulatory body that would likely be considered important to a reasonable investor in making an investment decision.

Conflicts of Interest

The directors and the officers of the Company are, or may become, directors or officers of other companies with businesses which may conflict with the business of the Company. Directors are required to act honestly and in good faith with a view to the best interests of the Company. In addition, directors in a conflict of interest position are required to disclose certain conflicts to the Company and to abstain from voting in connection with the matter. To the best of the Company's knowledge, there are no known existing or potential conflicts of interest between the Company and a director or officer of the Company as a result of such individual's outside business interests at the date hereof. However, certain of the directors and officers of the Company serve as directors and/or officers of other companies. Accordingly, conflicts of interest may arise which could influence these individuals in evaluating possible acquisitions or in generally acting on behalf of the Company. See "Risk Factors — Conflicts of interest may arise and may not be disclosed and dealt with appropriately by certain directors and officers of the Company."

EMPLOYEE INCENTIVE PLAN

The Company has adopted an employee incentive plan (the "EIP"). The EIP was approved by the shareholders of the Company at its annual general meeting on July 19, 2017. The following is a summary of the material terms of the EIP, which is qualified in its entirety by the provisions of the EIP:

- the EIP sets out the framework for the offer of Ordinary Shares, options to acquire Ordinary Shares ("**Options**") and performance rights to acquire Ordinary Shares ("**Performance Rights**") by the Company;
- Ordinary Shares, Options or Performance Rights under the EIP may be granted to employees of the Company or its subsidiaries and to members of the Board. In accordance with the ASX Rules, the granting of securities under the EIP to directors of the Company requires prior shareholder approval;
- the EIP does not have a limit as to the number of Ordinary Shares, Options or Performance Rights that may be granted to insiders of the Company or to any one person under the EIP;

- the Board has the discretion to determine the issue price of the Ordinary Shares, Option or Performance Right and the exercise price of an Option or a Performance Right, which may, at the discretion of the Board, be below the market price of the Ordinary Shares;
- in making its decision to issue Ordinary Shares, Options or Performance Rights, the Board may decide the number of securities and the vesting conditions which are to apply in respect of the securities. The Board has broad flexibility to issue Ordinary Shares, Options or Performance Rights having regard to a range of potential vesting criteria and conditions;
- the Board has the discretion to approve transfers of Options or Performance Rights granted to participants under the EIP;
- in certain circumstances, unvested Options or Performance Rights will immediately lapse and any unvested Shares held by the participant will be forfeited if the relevant person is a “bad leaver” as distinct from a “good leaver”;
- if a participant acts fraudulently or dishonestly or is in breach of their obligations to the Company or its subsidiaries, the Board may determine that any unvested Performance Rights or Options held by the participant immediately lapse and that any unvested Ordinary Shares held by the participant be forfeited;
- in certain circumstances, Ordinary Shares, Performance Rights or Options can vest early, including following a change of control or other events of a similar nature. For the purposes of this rule, a change of control event occurs in a number of scenarios in which a third party acquires 50% or more of the Company’s Ordinary Shares;
- the total number of Ordinary Shares that would be issued were each Option, Performance Right and Ordinary Share under the EIP exercised or vested (as applicable), plus the number of Ordinary Shares issued in the previous three years under the EIP, must not, at any time, exceed 5% of the total number of Ordinary Shares on issue. Except that any issuance of Ordinary Shares, Options and Performance Rights that is approved by shareholders of the Company is not included in such total;
- the Board has discretion to impose restrictions (except to the extent prohibited by law or the ASX Rules) on Ordinary Shares issued or transferred to a participant on vesting of an Option or a Performance Right, and the Company may implement appropriate procedures to restrict a participant from so dealing in the Ordinary Shares;
- in respect of vested Options or Performance Rights, if the Board becomes aware of an event which would have resulted in vesting criteria not being satisfied, such as a material misstatement in the Company’s financial statements during the vesting period, any affected vested Options or Rights may be cancelled for no consideration;
- in the event of any reorganisation of the issued capital of the Company on, or prior to, the expiry of the Performance Rights or Options, the rights of the relevant security holder can be changed in the discretion of the Board, including to comply with the applicable ASX Rules in force at the time of the reorganisation; and
- the Board is granted a certain level of discretion under the EIP, including the power to amend the rules under which the EIP is governed and to waive vesting conditions, forfeiture conditions or disposal restrictions.

In addition to being a “designated foreign issuer” under NI 71-102 for the current financial year (see heading entitled “Designated Foreign Issuer Status” above), the Company meets the definition of an Eligible Interlisted Issuer (as such term is defined in the TSX Company Manual (the “**TSX Manual**”)). As a result, the TSX has granted the Company an exemption from the requirement that the EIP comply

with the standards set out in Section 613 of the TSX Manual. The EIP is governed by the ASX Rules and Australian corporate law.

LEGAL PROCEEDINGS AND REGULATORY ACTIONS

Since the beginning of the most recently completed financial year there have been no legal proceedings to which the Company is or was a party or of which any of its subsidiaries or the Clean TeQ Sunrise Project is or was the subject of, nor are any such proceedings known to the Company to be contemplated.

In the past three years, the Company has not had any penalties or sanctions imposed on it by, or entered into any settlement agreements with, a court or a securities regulator relating to securities laws.

AUDIT COMMITTEE INFORMATION

Pursuant to the provisions of National Instrument 52-110 —*Audit Committees* (“**NI 52-110**”), the Company is required to disclose certain information concerning its audit committee including the audit committee’s charter, the composition of the audit committee and its relationship with its independent auditors. Such information is set forth below. The charter of the Company’s audit committee is attached as Appendix “A”.

Overview

The Audit Committee was formed to assist the Board in fulfilling its oversight responsibilities with respect to (i) the Company’s financial reporting and disclosure requirements, ensuring that an effective risk management and financial control framework has been implemented and tested by management of the Company and (ii) external and internal audit processes. The Audit Committee reviews the adequacy and effectiveness of the Company’s system of internal control and management information systems through discussions with management and the external auditors to ensure that Clean TeQ maintains necessary records to fairly reflect its transactions, effective internal control systems and adequate processes for assessing risk of misstatement of financial statements and detecting control weaknesses or fraud. The Audit Committee also oversees and assesses the quality and results of the external audit and reviews the independence of the external auditors.

Composition of Audit Committee

The Audit Committee is comprised of Mr. Knight (Chair), Mr. Finlayson and Ms. Loader. Each of Mr. Knight, Mr. Finlayson and Ms. Loader is “financially literate”, and each is “independent”, within the meaning of NI 52-110. See “Directors and Executive Officers” for information concerning members of the audit committee, including their relevant education and experience.

Audit Committee Oversight

At no time since incorporation was a recommendation of the Audit Committee to nominate or compensate an external auditor not adopted by the Board.

Reliance on Certain Exemptions

At no time since the commencement of the Company’s most recently completed financial year has the Company relied on the exemptions in Section 2.4 of NI 52-110 in relation to “De Minimis Non-Audit Services” or any exemption provided by Part 8 of NI 52-110.

Pre-Approval Policies and Procedures

The Company has not adopted any specific policies in relation to the engagement of non-audit services.

External Auditor Service Fees

The following table provides information about the fees billed to the Company for professional services rendered to the Company by external auditors during the fiscal years ended 2017 and 2016:

External Auditors	2017 A\$	2016 A\$
Audit Fees ⁽¹⁾	64,201	60,000
Audit Related Fees ⁽²⁾	-	-
Tax Fees ⁽³⁾	76,500	88,650
All Other Fees ⁽⁴⁾	-	-
Total⁽⁵⁾	140,701	148,650

Notes:

- (1) Audit fees were for professional services rendered by the auditors for the audit of the Company's annual financial statements.
- (2) Audit-related fees are for services related to performance of limited procedures performed by the Company's auditors related to interim reports as well as services provided in connection with statutory and regulatory filings.
- (3) Tax fees are for tax compliance, tax advice and tax planning.
- (4) All other fees for services performed by the Company's auditors.
- (5) These fees only represent professional services rendered and do not include any out-of-pocket disbursements or fees associated with filings made on the Company's behalf. These additional costs are not material as compared to the total professional services fees for each year.

INTERESTS OF MANAGEMENT AND OTHERS IN MATERIAL TRANSACTIONS

Other than as described below and elsewhere in this AIF, there are no material interests, direct or indirect, of any director or executive officer of the Company, any person or Company that beneficially owns, or controls or directs, directly or indirectly, more than 10% of the outstanding Ordinary Shares, or any associate or affiliate of any of such persons or companies, in any transaction within the three years before the date of this AIF that has materially affected or is reasonably expected to materially affect the Company or a subsidiary of the Company.

TRANSFER AGENTS AND REGISTRARS

The transfer agent and registrar for the Ordinary Shares in Australia is Computershare Investor Services Pty Limited with its principal office in Abbotsford, Victoria, Australia, and in Canada is Computershare Investor Services Inc. with its principal office in Toronto, Ontario.

MATERIAL CONTRACTS

Except for contracts entered into by the Company in the ordinary course of business or otherwise disclosed herein, the following is the only material contract of the Company:

1. Product Binding Offtake Agreement between dated August 30, 2017 between Scandium21 Pty Ltd. and Beijing Easpring Material Technology Co., Ltd.

INTERESTS OF EXPERTS

Names of Experts

KPMG LLP, Chartered Accountants, have advised that they are independent of the Company within the meaning of the Australian Corporations Act.

The scientific and technical information in this AIF regarding the Project referred to in the "Description of the Business" section is based on the Technical Report.

Interests of Experts

To the knowledge of the Company, as of the date hereof, none of KPMG LLP or any of their "designated professionals" as defined in NI 51-102, hold any beneficial interest in, directly or indirectly, Ordinary

Shares, or securities convertible into Ordinary Shares, equal to or greater than one percent of the issued and outstanding Ordinary Shares.

ADDITIONAL INFORMATION

Additional information relating to the Company may be found on SEDAR at www.sedar.com.

Additional information, including directors' and officers' remuneration and indebtedness, principal holders of the Corporation's securities and securities authorized for issuance under equity compensation plans will be contained in the Company's management proxy circular for its upcoming annual general meeting.

Additional financial information is provided in the Company's audited consolidated financial statements for the year ended June 30, 2017.

SCHEDULE “A”

INTERPRETATION

Defined Terms

Certain terms are limited to one section of the AIF and are defined directly in the body of the AIF. Other terms are used throughout, and are defined as follows:

“**ASX**” means the Australian Securities Exchange;

“**ASX Rules**” means the listing rules of the ASX;

“**Board**” means the board of directors of Clean TeQ;

“**Company**” has the meaning ascribed thereto under the heading “*Forward-Looking Statements*”;

“**Clean TeQ**” means Clean TeQ Holdings Limited;

“**IRR**” means internal rate of return;

“**Ordinary Shares**” means the ordinary shares in the capital of Clean TeQ;

“**NI 43-101**” means National Instrument 43-101 – *Standards of Disclosure for Mineral Projects*;

“**NI 52-110**” means National Instrument 52-110 – *Audit Committees*;

“**NPV**” means net present value;

“**Qualified Person**” means an individual who is a “Qualified Person” or “QP” within the meaning of NI 43-101;

“**SEDAR**” means the System for Electronic Document Analysis and Retrieval operated by the securities regulatory authorities in each of the provinces and territories of Canada;

“**Clean TeQ Sunrise Project**” means the Company’s 100% owned Clean TeQ Sunrise nickel/cobalt/scandium project in New South Wales, Australia;

“**Technical Report**” has the meaning ascribed thereto under the heading “*Definitions and Other Information – Scientific and Technical Information*”;

“**TSX**” means the Toronto Stock Exchange; and

“**U.S.**” or “**United States**” mean the United States of America, its territories or possessions, any state of the United States and the District of Columbia.

ABBREVIATIONS

“**CIM**” means Canadian Institute of Mining, Metallurgy and Petroleum;

“**CRMs**” mean certified reference materials;

“**Cu**” means copper;

“**Cr**” means chrome;

“**Fe**” means iron;

“**g/t**” means grams per tonne;

“**km**” means kilometres;

“**kt**” means kilotonne;

“**Ktpa**” means kilotonne per annum;

“**lb**” means pound;

“**m**” means metre;

“**Ma**” means million years ago;

“**mL**” means metre level;

“**mm**” means millimeters;

“**M**” means million;

“**Moz**” means million oz;

“**Mt**” means million tonnes;

“**Mtpa**” means million tonnes per annum;

“**MW**” means megawatt;

“**Ni**” means nickel;

“**oz**” means a troy ounce;

“**Pd**” means palladium;

“**PGE**” means platinum group elements, including platinum, palladium and rhodium;

“**ppb**” means parts per billion;

“**Pt**” means platinum;

“**RC**” means reverse circulation;

“**Rh**” means rhodium;

“**S**” means sulphur;

“**SxEw**” means solvent extraction and electrowinning;

“**tpa**” means tonnes per annum;

“**µm**” means micrometre (micron);

“**XRF**” means X-ray fluorescence; and

“**Zn**” means zinc.

SCHEDULE “B”

AUDIT COMMITTEE CHARTER

Audit committee charter

Clean TeQ Holdings Limited ACN 127 457 916 (**Company**)

Audit committee charter

1. Introduction

- 1.1 The Audit Committee is a committee of the board of directors (**Board**) of Clean TeQ Holdings Limited (**Company**).
- 1.2 The board established the Audit Committee under the Company's constitution.
- 1.3 This charter sets out the scope of the Audit Committee's responsibilities in relation to the Company and its controlled entities (**Group**).
- 1.4 The role of the Audit Committee is not an executive role.

2. Objective

The objectives of the Audit Committee are to:

- (a) help the Board achieve its objective in relation to:
 - (i) financial reporting;
 - (ii) the application of accounting policies;
 - (iii) business policies and practices;
 - (iv) legal and regulatory compliance; and
 - (v) internal control and risk management systems;
- (b) maintain and improve the quality, credibility and objectivity of the financial accountability process (including financial reporting on a consolidated basis);
- (c) promote a culture of compliance;
- (d) ensure effective communication between the Board and the senior compliance manager;
- (e) provide a forum for communication between the Board and senior financial and compliance management;
- (f) ensure effective internal (if relevant) and external audit functions and communication between the Board and the external and internal auditors; and
- (g) ensure compliance strategies and compliance function are effective.

3. External financial reporting

The Audit Committee is responsible for:

- (a) assessing the appropriateness and application of the Group's accounting policies and principles and any changes to them, so that they accord with the applicable financial reporting framework;

- (b) obtaining an independent judgment from the external auditor about:
 - (i) the acceptability and appropriateness of accounting policies and principles put forward by management; and
 - (ii) the clarity of current or proposed financial disclosure practices as put forward by management;
- (c) assessing any significant estimates or judgments in the financial reports (including those in any consolidated financial statements) by:
 - (i) querying management as how they were made; and
 - (ii) querying the external auditors as how they concluded that those estimates were reasonable;
- (d) reviewing compliance with all related party disclosures required (where applicable) by accounting standards and the *Corporations Act 2001* (Cth) (**Act**);
- (e) assessing information from internal and external auditors that may affect the quality of financial reports (for example, actual and potential material audit adjustments, financial report disclosures, non-compliance with laws and regulations, and internal control issues);
- (f) reviewing any half-yearly and annual financial reports (including those prepared on a consolidated basis) with management, advisers and the internal and external auditors (as appropriate) to assess (among other things):
 - (i) the compliance of accounts with accounting standards and the Act; and
 - (ii) the nature and impact of any changes in accounting policies during the applicable period;
- (g) discussing any draft audit opinion letter with the external auditors before it is finalised;
- (h) receiving any management letter from the external auditors;
- (i) recommending for adoption by the board interim and final financial reports and the annual report;
- (j) reviewing documents and reports to regulators and recommending to the board their approval or amendment; and
- (k) following up on any matter raised by the board regarding financial reports, audit opinions and management letters.

4. Risk management and internal control

The Audit Committee is responsible for:

Risk management and internal compliance and control systems

- (a) overseeing the establishment and implementation of risk management and internal compliance and control systems and ensuring there is a mechanism for assessing the efficiency and effectiveness of those systems; and

- (b) approving and recommending to the board for adoption policies and procedures on risk oversight and management to establish an effective and efficient system for:
 - (i) identifying, assessing, monitoring and managing risk; and
 - (ii) disclosing any material change to the risk profile;
- (c) regularly reviewing and updating the risk profile;
- (d) assessing the adequacy of the internal risk control system with management and internal and external auditors;
- (e) monitoring the effectiveness of the internal risk control system;
- (f) ensuring the risk management system takes into account all material risks, including risks arising from:
 - (i) implementing strategies (strategic risk);
 - (ii) operations or external events (operational risk);
 - (iii) legal and regulatory compliance (legal risk);
 - (iv) changes in community expectation of corporate behaviour (reputation risk);
 - (v) a counterparty's financial obligations within a contract (credit risk);
 - (vi) changes in financial and physical market prices (market risk); and
 - (vii) being unable to fund operations or convert assets into cash (liquidity risk);
- (g) assessing if management has controls in place for unusual transactions and any potential transactions that may carry more than an acceptable degree of risk;

Key financial risk

- (h) assessing and prioritising the areas of greatest potential financial risk, including:
 - (i) safeguarding assets;
 - (ii) litigation and claims;
 - (iii) non-compliance with laws, regulations, standards and best practice guidelines that may result in significant financial loss; and
 - (iv) maintenance of proper accounting records;
- (i) assessing the internal process for determining areas of greatest potential financial risk;
- (j) assessing and monitoring the management of areas of greatest potential financial risk;
- (k) reporting to the board on the adequacy of the financial risk management;

Legal and regulatory risk

- (l) assessing and prioritising the areas of greatest legal and regulatory risk;
- (m) assessing the internal process for determining, monitoring and managing areas of greatest legal and regulatory risk;

- (n) receiving reports from management of any actual or suspected fraud, theft or other breach of the law;
- (o) monitoring compliance with legal and regulatory obligations;
- (p) reporting and making recommendations to the Board regarding:
 - (i) the management of areas of greatest legal and regulatory risk (including fraud and theft); and
 - (ii) compliance with legal and regulatory obligations;
- (q) receiving and reviewing reports from the senior compliance manager;

Disclosure and reporting

- (r) ensuring management establishes a comprehensive process to capture information that must be disclosed to ASX;
- (s) reviewing management's processes for ensuring and monitoring compliance with laws, regulations and other requirements relating to the external reporting of financial and non-financial information (including, among other things, preliminary announcements, interim reporting, open or one-on-one briefings and continuous disclosure);
- (t) assessing management's processes for ensuring non-financial information in documents (both public and internal) does not conflict inappropriately with financial reports and other documents;
- (u) assessing internal control systems relating to the release of potentially adverse information; and
- (v) reviewing for completeness and accuracy the reporting of corporate governance practices in accordance with the ASX Listing Rules.

5. External audit

The Audit Committee is responsible for:

- (a) approving and recommending to the Board for acceptance, the terms of engagement with the external auditor at the beginning of each year;
- (b) regularly reviewing with the external auditor:
 - (i) the scope of the external audit;
 - (ii) identified risk areas; and
 - (iii) any other agreed procedures;
- (c) approving and recommending to the Board for adoption, policies and procedures for appointing or removing an external auditor, including criteria for:
 - (i) technical and professional competency;
 - (ii) adequacy of resources; and
 - (iii) experience, integrity, objectivity and independence;

- (d) recommending to the Board for approval, the appointment or removal of an external auditor based on those policies and procedures referred to in paragraph (c);
- (e) reviewing and assessing on a regular basis the compliance of the external auditor with criteria referred to in paragraph (c);
- (f) recommending to the Board the remuneration of the external auditor;
- (g) regularly reviewing the effectiveness and independence of the external auditor taking into account:
 - (i) the length of appointment;
 - (ii) the last dates lead engagement partners were rotated;
 - (iii) an analysis and disclosure of fees paid to external auditors, including the materiality of fees paid for non-audit services and the nature of those services; and
 - (iv) any relationships with the Group or any other body or organisation that may impair or appear to impair the external auditor's independence;
- (h) satisfying itself that the external auditor can do an effective, comprehensive and complete audit for the external auditor's set fee;
- (i) recommending to the Board for approval the types of non-audit services that the external auditor may provide without impairing or appearing to impair the external auditor's independence;
- (j) meeting periodically with the external auditors and inviting them to attend Audit Committee meetings to:
 - (i) review their plans for carrying out internal control reviews;
 - (ii) consider any comments made in the external auditor's management letter, particularly, any comments about material weaknesses in internal controls and management's response to those matters; and
 - (iii) make recommendations to the Board;
- (k) asking the external auditor if there have been any significant disagreements with management, whether or not they have been resolved;
- (l) monitoring and reporting to the Board on management's response to the external auditor's findings and recommendations;
- (m) reviewing all representation letters signed by management and ensuring information provided is complete and appropriate; and
- (n) receiving and reviewing the reports of the external auditor.

6. Internal audit

The Audit Committee is responsible for determining the need and appropriateness of an internal audit function within the Company. At the present time, given the nature and scope of the Company's business operations, the Board have resolved not to maintain an internal audit

function. The Board has resolved that the requirement for an internal audit capability be reviewed regularly on the recommendation of the Audit Committee.

If it is determined the Company ought have an internal audit function, the Audit Committee will be responsible for:

- (a) ratifying the engagement and dismissal by management of any chief internal audit executive;
- (b) ensuring any chief internal audit executive is independent of the external auditor;
- (c) ensuring the external auditor does not provide internal audit services;
- (d) overseeing the scope of the internal audit, including reviewing the internal audit team's mission, charter, qualifications and resources;
- (e) reviewing and approving the scope of the internal audit plan and work programme;
- (f) monitoring the progress of the internal audit work programme and considering the implications of the internal audit findings for the control environment;
- (g) monitoring and reporting to the Board on management's responsiveness to internal audit findings and recommendations;
- (h) evaluating the process for monitoring and assessing the effectiveness of the internal audit function;
- (i) overseeing the liaison between the internal audit team and the external auditor;
- (j) receiving and reviewing the internal audit team's reports; and
- (k) ensuring the internal audit team reports directly to the Audit Committee.

7. Other responsibilities

The Audit Committee is responsible for:

- (a) overseeing the implementation of the Group's corporate code of conduct and assessing compliance with it;
- (b) overseeing the implementation of the Group's code of conduct for directors and senior executives of and assessing compliance with it;
- (c) assessing and recommending to the Board for adoption the scope, cover and cost of insurance, including insurance relating to directors and officers liability, company reimbursement, professional indemnity, crime, special accident and trustees liability;
- (d) if it considers appropriate, investigating any complaint or allegation made to it;
- (e) reporting to the Board on any industry development affecting the control environment;
- (f) reviewing and monitoring any related party transaction and recommending its approval; and

- (g) ensuring the audit, risk management and compliance policies and procedures are adequately documented and that those documents are reviewed and updated for any legal and regulatory developments.

8. Audit Committee composition

- 8.1 The Company notes that the ASX corporate governance guidelines recommend that the Audit Committee should comprise:
 - (a) at least three directors;
 - (b) all non-executive directors; and
 - (c) a majority of independent directors,the chairperson of which should be an independent director and should not be the chairperson of the Board.
- 8.2 While the Company will aim to have an Audit Committee that complies with the size and composition guidelines outlined in paragraph 8.1 above, this is not presently possible and may not always be practicable in the future given the size of the board and the circumstances of the Group, including the nature of the Group's business. Accordingly, the Board has absolute discretion to determine the appropriate size and composition of the Audit Committee from time to time.
- 8.3 The Audit Committee will comprise three non-executive independent directors nominated by the Board from time to time.
- 8.4 The Audit Committee will appoint a secretary.
- 8.5 The Audit Committee must be of sufficient size, independence and technical expertise to effectively discharge its mandate.
- 8.6 The Audit Committee must include at least one member with experience of financial and accounting matters.
- 8.7 Each member of the Audit Committee should have an understanding of the industry in which the Group operates.
- 8.8 The Board will decide appointments, rotations and resignations within the Audit Committee having regard to the ASX Listing Rules and the Act.
- 8.9 A member may act by their alternate.

9. Audit Committee meetings

- 9.1 The Audit Committee will meet as often as it considers necessary.
- 9.2 A quorum for an Audit Committee meeting is two Audit Committee members.
- 9.3 Audit Committee meetings may be held by any technological means allowing its members to participate in discussions even if all of them are not physically present in the same place. A member who is not physically present but participating by technological means is taken to be present.
- 9.4 The Audit Committee may pass or approve a resolution without holding a meeting in accordance with the procedures (so far as they are appropriate) in section 248A of the Act .

- 9.5 The Audit Committee may invite other persons it regards appropriate to attend Audit Committee meetings.

10. Minutes of Audit Committee meetings

- 10.1 The Audit Committee must keep minutes of its meetings.
- 10.2 Minutes of each Audit Committee meeting must be included in the papers for the next full board meeting after each meeting of the Audit Committee.
- 10.3 Minutes must be distributed to all Audit Committee members, after the Audit Committee chairperson has approved them.
- 10.4 Minutes, agenda and supporting papers are available to directors upon request to the Audit Committee secretary, except if there is a conflict of interest.

11. Reporting to the board

The Audit Committee chairperson must report the Audit Committee's findings to the Board after each Audit Committee meeting.

12. Access to information and independent advice

- 12.1 The Audit Committee may seek any information it considers necessary to fulfil its responsibilities.
- 12.2 The Audit Committee has access to:
- (a) management to seek explanations and information from management; and
 - (b) internal and external auditors to seek explanations and information from them, without management being present.
- 12.3 The Audit Committee may seek professional advice from employees of the Group and from appropriate external advisers, at the Company's cost. The Audit Committee may meet with these external advisers without management being present.

13. Review and changes to this charter

- 13.1 The Audit Committee will review this charter annually or as often as it considers necessary.
- 13.2 The Board may change this charter from time to time by resolution.

14. Approved and adopted

This charter was approved and adopted by the Board on 28 September 2011.

Date _____

Signed _____
Chairperson of the board of directors
of Clean TeQ Holdings Limited