

**FEASIBILITY STUDY FINDS NOWA NOWA IRON PROJECT IS TECHNICALLY  
ROBUST WITH POSITIVE CASHFLOW**

**HIGHLIGHTS**

- Feasibility Study confirms the technical and financial viability of Nowa Nowa Iron Project.
- Study posits production of 1.0Mtpa, with LOM of 6 years.
- LOM production in base case underpinned by JORC Measured and Indicated Resources of 4.65Mt at 51.75% Fe
- Low capital cost of \$15.7 million (including contingency)
- Cash operating costs of A\$72.00 per tonne FOB (LOM average)
- Pre-tax NPV of A\$61.94 million and IRR of 11.8%

Eastern Resources Limited (“EFE” or the “Company”) is pleased to report on the results from the Feasibility Study (‘FS’) relating to the Nowa Nowa Project (‘Project’).

The Study is the third assessment undertaken by EFE for the entire Project following successful completion of the Scoping Study in 2012 and Feasibility Study in 2014. This Study has been revised as of January 2022 to reflect the current product philosophy and operational approach, along with updated financial metrics.

The FS shows the Project is technically robust and under the assumptions of the FS would be likely to generate positive financial returns.

**Overview**

This FS outlines the findings for the Project and includes assessment on the following:

- geology and mineral resource;
- metallurgical testwork;
- mining, crushing & screening;
- infrastructure requirements;
- utilities supply (power, water, fuel and communications);
- product haulage;
- port product handling and export;
- operations management and human resources;
- health and safety management;
- environmental and social impacts;

- project approvals process;
- cultural heritage and native title; and
- capital costs, operating costs and financial modelling.

### **Key Outcomes**

The following describes the key elements of the Project's base case:

- life of mine of approximately 6 years;
- mining from a single pit, the Five Mile deposit, using conventional drill, blast, load and haul mining methodology;
- produce approximately 1 Mtpa magnetite direct shipping ore (DSO) -30 mm product with average grade of 51.75% Fe over the life of mine;
- haulage via a trucking operation to the Eden port, 234 km one way from the mine site;
- approximately 12 - 14 shipments per annum exported through the port, operated by Pentarch Logistics (ANWE);
- capital cost of A\$15.7 million (15% contingency)
- cash operating costs of A\$72.00 per tonne of DSO including royalties (FOB); and
- pre-tax NPV (8%) of A\$61.94M and IRR of 11.8%.

### **Background**

The Company engaged Engenium Pty Ltd ("Engenium") to investigate the potential for development of a magnetite direct shipping ore<sup>1</sup> ("DSO") operation based on magnetite-rich iron ore deposits at its Five Mile deposit near Nowa Nowa in Eastern Victoria. DSO product would be trucked through existing road network to the Port of Eden in NSW, where the DSO product would be exported via existing port infrastructure.

For the purpose of the FS, the Project has been considered as a standalone project for Five Mile deposit only and the other deposits (e.g. Six Mile and Seven Mile) have been excluded from consideration at this point in time.

### **Project Location**

The Project is located 7 km north of the township of Nowa Nowa, Victoria. It is some 320km by road east of Melbourne, and approximately 234km by road west of the Port of Eden. (see Figure 1).

---

<sup>1</sup> No Ore Reserves in accordance with the JORC Code 2012 have been estimated. The word 'ore' where used in this announcement is not intended to imply the existence or likelihood of the estimation of ore reserves in accordance with the JORC Code 2012.



**Figure 1 – Project Location**

### JORC Mineral Resource

The Mineral Resource at Five Mile was estimated by H&SC in accordance with the JORC Code 2012.

H&SC estimated a total mineral resource of 9.05 Mt with an average iron content of 50.8%Fe, in the Measured, Indicated and Inferred categories as set out in Table 1 below. This estimate assumes a commercially minable lower cut-off of 40% iron.

Prospect	Measured		Indicated		Inferred		Total	
	Mt	Fe %	Mt	Fe %	Mt	Fe %	Mt	Fe %
Five Mile	2.25	52.8	4.32	50.4	2.49	49.7	9.05	50.8

**Table 1 - Five Mile Resource Estimate (cut off of 40% Fe)<sup>1</sup>**

### Project Operation

The operating strategy is summarised as follows:

- engage a mining contractor for ore extraction and stockpiling at the ROM pad;
- engage a mining contractor for crushing plant encompassing all crushing, screening, and stockpiling;
- engage a road haulage contractor for product haulage from the mine to the port;
- product unloading, stockpile, reclaim, ship loading and all charges at the port; and
- miscellaneous indirects and services for the supply of operations infrastructure and support.

The FS indicates a plan to produce magnetite DSO at a 1.0 million tonnes per annum over a six-year LOM (totally approximately 4.65 million tonnes), with the opportunity to expand production once existing inferred resources at Five Mile deposit is upgraded to measured and/or indicated resources.

An open cut mine is proposed, with an average waste to ore ratio of 3.22 over the six years mining including pre-strip period. Ore will be crushed and screened to produce DSO lump product ("Product"), with estimated average product grade of 51.75% over the LOM.

The Product will be trucked from mine to the Port of Eden predominantly by sealed road, where it will be stockpiled prior to being loaded directly into Panamax ship vessels for export to customers.

### **Opportunities and Risks**

The Company is studying further opportunities to enhance the value of the Project, include the potential as follows:

- Extending the LOM by upgrade existing inferred resources in Five Mile deposit to measured and/or indicated resources;
- Exploration upside based on areas of Seven Mile project where iron ore has been identified;
- Increasing the production rate materially to 1.5Mtpa;
- Improvements in operational efficiencies and reduction of operating costs
- Project partnership arrangement.

The key risks identified for the Project include:

- A significant strengthening of the Australian currency against the US currency;
- A significant decline in the iron ore price from the forecasted price in the FS;
- Delays in obtaining necessary approvals/permits;
- Restrictions in access to ANWE port facilities;
- Increased operating costs and shipping costs;
- Shortages in suitable staffing and contractors.

### **Cautionary Statement**

As the Feasibility Study for the Project utilises a portion of Inferred Resources, the Company draws attention to the following cautionary statement in accordance with the ASX Listing Rules.

The FS referred to in this announcement is based upon a JORC Compliant Mineral Resource Estimate (refer to the Company announcement dated 21 May 2014<sup>1</sup>).

The Company advises that the production targets in the FS uses measured and indicated resources as base case, and uses measured, indicated and inferred resources as upside case. The forecast financial information in this announcement is based on the base case only.

There is a low level of geological confidence associated with Inferred Mineral Resources and there is no certainty that further exploration work will result in the conversion of Inferred Mineral Resources to Indicated or Measured Mineral Resources or that the production targets of upside case reported in this announcement will be realized.

The Mineral Resource Estimate that underpins the FS has been prepared by a Competent Person, with a Competent Person's Statement in accordance with the JORC Code included in this announcement.

The Company has concluded that it has a reasonable basis for providing the forward-looking statements included in this announcement. The detailed reasons for this conclusion are outlined throughout this announcement.

### **Forward Looking Statements**

This announcement contains “forward-looking information” that is based on the Company’s expectations, estimates and projections as of the date on which the statements were made. This forward-looking information includes, among other things, statements with respect to the FS, the Company’s business strategy, plan, development, objectives, performance, outlook, growth, cash flow, projections, targets and expectations, mineral resources, ore reserves, results of exploration, production rates, costs, expenses, industry growth and other trend projections, generally, this forward looking information can be identified by the use of forward-looking terminology such as, “anticipate”, “project”, “target”, “likely”, “believe”, “estimate”, “expect”, “intend”, “may”, “would”, “should”, “scheduled”, “will”, “plan”, “forecast”, “evolve” and similar expressions. Persons reading this announcement are cautioned that such statements are only predictions, and that the Company’s actual future results or performance may be materially different.

The Company believes that the forward-looking information in this announcement is based on reasonable grounds having regard to the fact the production targets and forecast financial information in base case are underpinned by a 100% Measured and Indicated Mineral Resources and the relevant assumptions as set out in this announcement, and that the financial and other parameters on which production targets and financial forecasts are based are current, and that all assumptions on which production targets and those financial forecasts are based regarding future matters which of the nature cannot be known with reasonable certainty are made on a reasonable basis. However, neither the Company nor any other person makes or gives any representation, assurance or guarantee that the production targets or expected outcomes in this announcement will ultimately be achieved. The forward-looking information in this announcement is subject to known and unknown risks, uncertainties and other factors that may cause the Company’s actual results, level activity, performance or achievements to be materially different from those expressed or implied by such forward-looking information. Such risks include but are not limited to future prices and demand of iron and other metals; foreign exchange rates, availability of funding; results of further optimisation activities (including further exploration and metallurgical work); changes in project parameters as plans continue to be refined; failure of plant; equipment or processes to operate as anticipated; possible variations of ore grade or recovery rates; accident, labour disputes and other risks of the mining industry; delays in obtaining governmental approvals or financing or in the completion of development or construction activities and general business, economic, competitive, political and social uncertainties.

A number of key steps need to be completed in order to achieve production at the Project. Many of these steps are referred to in this announcement. Investors should note if there are delays associated with completing those steps, or completion of the steps does not yield the anticipated results, the actual estimated production and forecast financial information may differ materially from the FS results presented in this announcement.

These risks are not exhaustive of the factors that may affect or impact forward-looking information. These and other factors should be considered carefully, and readers should not place undue reliance on such forward-looking information. The Company disclaims any intent or obligations to revise any forward-looking statement whether as a result of new information, estimates, or options, future events or results or otherwise, unless required to do so by law.

## Feasibility Study – Summary

### Introduction

The FS has been overseen by project delivery and engineering consultancy Engenium, with inputs from Eastern Resources, specialist consultants, contract service operators, and vendors of equipment as follows:

Feasibility Study Component	Principal Input
<b>Executive Summary</b>	Engenium
<b>Introduction</b>	Engenium
<b>Geology and Mineral Resource</b>	Eastern Resources
<b>Metallurgical Testwork</b>	Engenium
<b>Mining</b>	Mining One
<b>Processing</b>	Engenium
<b>Infrastructure and Utilities</b>	Engenium
<b>Logistics</b>	Engenium
<b>Port Facilities</b>	Engenium/Eastern Resources
<b>Operations Management</b>	Engenium
<b>Human Resources</b>	Engenium
<b>Health and Safety Management</b>	Engenium
<b>Environmental and Social Impact Assessment</b>	AECOM
<b>Project Approvals Process – Mine and Port</b>	AECOM
<b>Cultural Heritage and Native Title</b>	Eastern Resources
<b>Capital and Operating Cost Estimation</b>	Engenium/Eastern Resources
<b>Market Analysis and Financing</b>	Eastern Resources
<b>Financial Analysis</b>	Engenium/Eastern Resources
<b>Risk Management</b>	Engenium
<b>Project Execution</b>	Engenium
<b>Project Status and Forward Work Program</b>	Engenium
<b>Study document preparation</b>	Engenium

### Project Location

The Project is in East Gippsland, Victoria. It is located 7 km north of the township of Nowa Nowa, Victoria. It is some 320km by road east of Melbourne, and approximately 234km by road west of the Port of Eden.

East Gippsland's major towns from west to east include Bairnsdale (the largest town and administrative centre), Paynesville, Lakes Entrance, Orbost and Mallacoota. Smaller, but significant,

towns in the more mountainous northern areas include Ensay, Swifts Creek, Omeo, and Buchan. The township of Nowa Nowa is located on the Princes Highway between Bairnsdale and Orbost, and the Project site is 7 km north of Nowa Nowa situated in the State forest.

### Tenure

On the 13 October 2011 EFE secured a two year option to purchase 100% of the Project from Waygara Mines Pty Ltd (Waygara). As part of the agreement, EFE would acquire the associated exploration licence (EL) and all available data relating to previous drilling undertaken by Waygara and the Victorian Department of Mines. On the 14 February 2012 EFE exercised its option and the transfer of EL 4509 was completed.

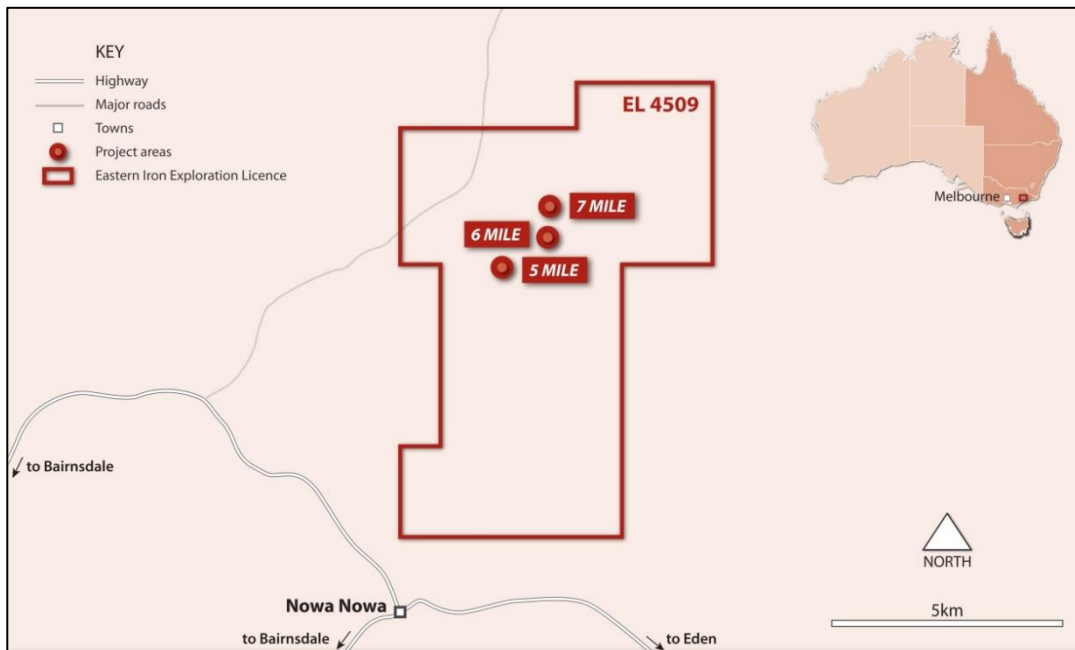

**Figure 2 – Exploration Licence 4509**

Subsequently, EL 4509 was replaced by EL 6183. In addition to EL 4509, EFE were granted a mining licence (MIN 5571) in 2014. EFE surrendered MIN 5571 in 2017 and subsequently applied for a retention licence (RL 006488) which was granted in December 2021.

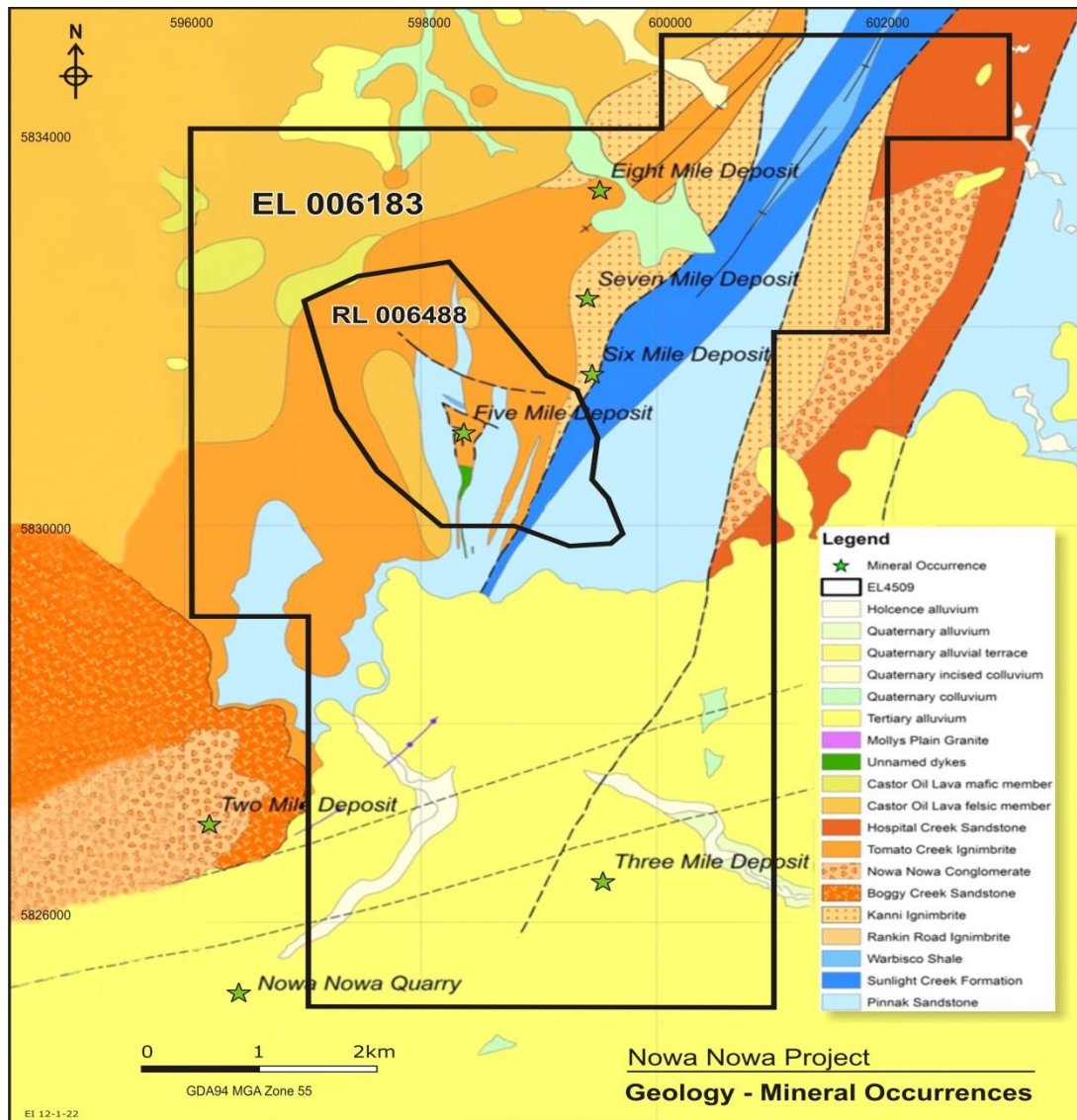

**Figure 3 – Exploration Licence 006183 and Retention Licence 006488**

For the purpose of the Feasibility Study (FS) the Project has been considered as a standalone project and the other deposits (e.g. Six Mile and Seven Mile) have been excluded from consideration at this point in time.

### Geology and Mineral Resources

The principal mineralised occurrences at Nowa Nowa, are the “ironstones”, represented by Two Mile, Three Mile, Five Mile, Seven Mile, Eight Mile, Harris Creek and the massive hydrothermal alteration typically mapped at the Nowa Nowa Quarry.

- **Geology**

The Project is situated in the Lachlan Orogen, which extends from eastern Tasmania, through central and eastern Victoria, into New South Wales and Queensland. The mineralisation is characterised by massive magnetite-haematite with lesser chlorite, talc/carbonates, pyrite, quartz and chalcopyrite. Magnetite is late stage and replaces specular haematite. Chalcopyrite occurs with pyrite in veinlets in the high sulphide zones and is disseminated in magnetite, and as rims around pyrite and



magnetite (McGee & Munro 1971). The mineralised body at the Five Mile deposit occurs below a variable thickness of younger tertiary sands/gravels and volcanic rock sequences, between 25 and 140 m thick, and as such is largely unweathered. Primary mineralisation consists predominantly of magnetite with hematite becoming more common at depth. The mineralisation is generally massive with little internal waste.

The geological model of the Five Mile deposit is reasonably simple and integral to the resource estimation procedure with the Fe mineralisation interpreted to be replacing the limestone unit. It is however complicated by the presence of at least two faults that truncate mineralisation to the west and south of the deposit. It is possible that unidentified faults or folds may occur in this region. The wireframes constraining mineralisation, external waste, and, in the case of Five Mile, the limestone unit, were used to define assays used for estimation of blocks in corresponding units.

- Sampling, subsampling, and drilling techniques

Reverse circulation (RC) percussion drillholes were sampled over 2 metre downhole depth intervals via a sealed collar dust diverter and cyclone. Diamond core was sampled nominally at 2 metre composite intervals at the boundaries of lithological contacts. Diamond core was cut using a core saw for composite sampling. Both RC and diamond core drill samples were 3-4kg in weight to produce a fused disk for ME-XRF21 spectrometry analysis.

RC percussion drillholes were drilled using a 5 ½ inch RC face-sampling buttoned drill bit. Diamond core drilling was drilled using triple-tube conventional wireline HQ and PQ diameter techniques.

Several historical drill holes were ‘twinned’ with drill holes from EFE’s later drilling programmes. These validated the geology and confirmed the iron grades of the ore body, providing the basis for a portion of the resource to be upgraded from Inferred to a Measured and Indicated category as confirmed in the updated Mineral Resource Estimate released on 21 May 2014.

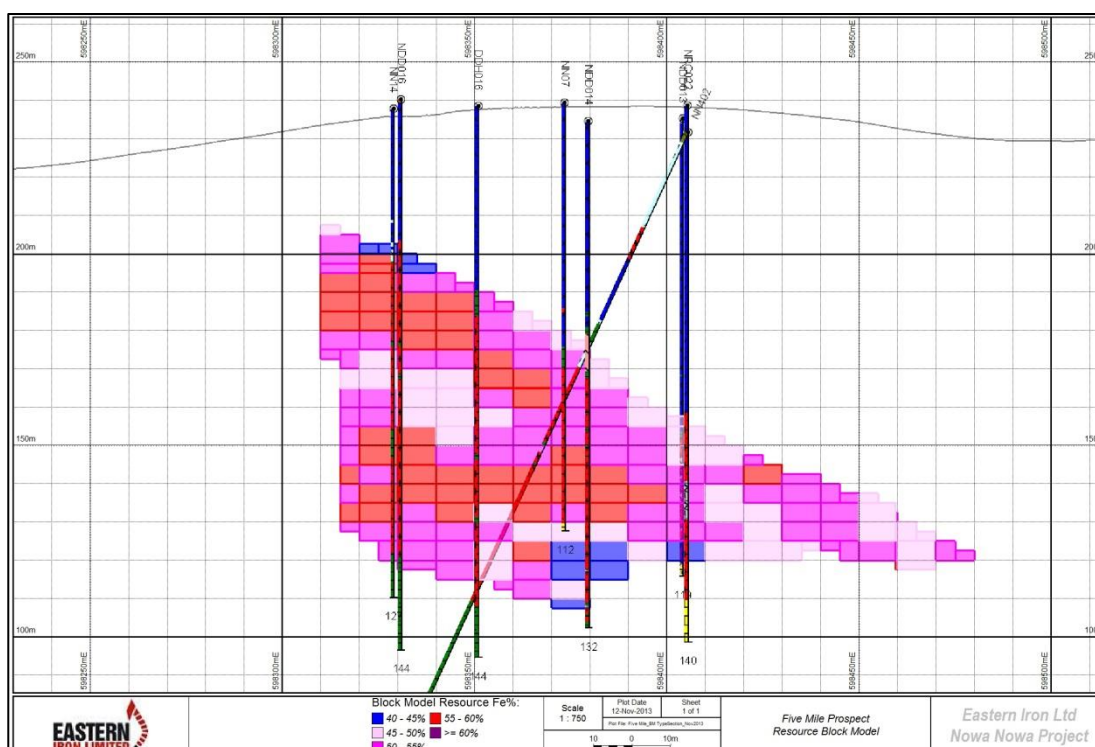

**Figure 4 – Cross Section of the Five Mile Mineralisation Showing Estimated Blocks and Drill Hole Assays by Iron Grade**

- Criteria used for classification

At the Five Mile deposit, nineteen and eight EFE drillholes were sited on the main magnetic anomalies respectively. Staggered drill-centres were nominally spaced at 25 metres across east-west cross-sections and 25 metres between drill profiles. Also six of the previously drillholes drilled by Victorian Geological Survey (GSV) were twinned by EFE drilling to confirm their results. The RC and diamond core samples were composited nominally into 2 metre intervals for head assay analysis.

The Mineral Resource estimates at Five Mile deposit have been classified according to the search pass so that blocks populated in pass one are classified as Measured, blocks populated in pass two have been classified as Indicated and blocks populated in pass three are classified as Inferred. The resources in the northern part of Five Mile is classified as Inferred due to uncertainties in the geometry of mineralisation. H&S Consultants believes the confidence in tonnage and grade estimates, the continuity of geology and grade, and the distribution of the data reflect the Measured, Indicated and Inferred categorisation.

- Sample analysis

EFE samples were assayed by ALS Global Laboratories. EFE collected field duplicate samples throughout all drillholes. Duplicate samples were analysed by ALS Global and triplicate QAQC samples by Bureau Veritas Mineral Laboratories Perth. Good reproducibility was obtained in the comparison of results from the umpire quality control programme. A minor high bias for total SiO<sub>2</sub> and Al<sub>2</sub>O<sub>3</sub> (~0.15%) and corresponding low bias for Fe (~0.15%) was present in the assay standards. These biases are considered insignificant.

- Estimation methodology

H&S Consultants was commissioned by EFE to undertake a resource estimation of the Project. This resource estimate was compiled for the Five Mile mineralised body using data from 1,046 assays from 41 diamond and 10 reverse circulation (RC) drill holes totalling 5,447 m. All but four of the drill holes are vertical and are on a nominal 25 x 25 m grid with an average depth of 107 m.

The resources at Nowa Nowa were estimated using Ordinary Kriging in the Micromine software. At Five Mile the mineralisation is interpreted to occur as a replacement of the limestone unit. Wireframes representing the mineralised and limestone units were created. Block dimensions at Five Mile is 10 x 10 x 5 m (E, N, RL respectively). The Five Mile deposit has been drilled on an irregular nominal grid of around 25 x 25 m. The average sample interval is two metres. Each element was estimated separately by Ordinary Kriging. At Five Mile deposit, assays from both the mineralised unit and the limestone unit were used to estimate blocks inside the mineralised wireframe. Assays from the limestone unit (only) were used to estimate blocks in the limestone wireframe and assays outside the wireframes (only) were used to estimate blocks outside the wireframes. No top cutting was applied as extreme values were not significant. Concentrations of Fe, SiO<sub>2</sub>, Al<sub>2</sub>O<sub>3</sub>, P, S and Cu were included in the resource estimation. No assumptions were made regarding the recovery of by-products as estimated grades are unlikely to result in economic by-products.

- Cut-off grade(s)

A lower cut-off grade of 40% Fe has been used in the resource estimate for the Five Mile deposit. No top cuts have been applied.

- Mining and metallurgical parameters

The Five Mile deposit was estimated on the assumption that the material will be mined by open cut methods. Minimum mining dimensions are envisioned to be around 5 x 5 x 5 m. The resource estimation includes internal mining dilution. In the FS, the Company plans to produce magnetite DSO products from the Project. The DSO products will be produced by crushing and screening, and no on-site beneficiation will be conducted. Previously metallurgical testwork completed by the Company in 2013 and in 2014 including DTR, dry LIMS and wet LIMS has shown that the Nowa Nowa iron

mineralisation is amenable to a range of magnetic separation and beneficiation techniques to produce an upgraded and saleable iron ore product.

A JORC compliant total resource of 9.05 Mt @ 50.8% Fe was estimated by H&S Consultants for the Five Mile deposit (Table 2). The estimate used historical drilling data compiled by EFE and results from EFE’s drilling programmes.

Prospect	Measured		Indicated		Inferred		Total	
	Mt	Fe %	Mt	Fe %	Mt	Fe %	Mt	Fe %
Five Mile	2.25	52.8	4.32	50.4	2.49	49.7	9.05	50.8

**Table 2 – Five Mile Resource Estimate (40% Fe Cut-Off) <sup>1</sup>**

### Metallurgical Testwork

- Comminution**

Four 1 m long 3/4 PQ diamond core samples were supplied for the initial testwork in 2014 at the ALS Laboratory in Perth, Western Australia. This was reported in Engenium document *9231B-REP-0000-Z-002 Metallurgical Testwork Report (2014)*.

The comminution testwork results indicate that neither the fresh nor the oxidised ore zones would be hard enough to present problems to current comminution equipment. Based on this data, there is no requirement to consider any special comminution design in project development.

The comminution results are given in Table 3.

Parameter	Unit	Average
Apparent SG - Oxidised	t/m <sup>3</sup>	3.96
Apparent SG - Fresh	t/m <sup>3</sup>	3.81
Unconfined Compressive Strength	MPa	54.8
Abrasion Index		0.10
Crushing Work Index	kWh/t	3.6
Rod Mill Work Index Oxidised	kWh/t	15.9
Rod Mill Work Index Fresh	kWh/t	10.9
SMC Test - Oxidised	A x B	90
SMC Test - Fresh	A x B	98

**Table 3 – Comminution Test Results**

- Dust Extinction Moisture**

In 2021, further testwork was performed at the ALS Laboratory in Perth, Western Australia, on a sample of mineralised material.

A subsample of the mineralised material was crushed to -6.3 mm and the dust extinction moisture (DEM) level determined. The reported DEM is low, at 1.2% moisture, showing that the sample does not produce much dust. The drained moisture level is over triple the DEM, therefore dust emissions should be controllable by conventional means due to surface evaporation.

- **Heap Drainage**

Heap drainage testwork was also performed at the ALS Laboratory in Perth, Western Australia.

A heap drainage test was performed on a sample of the mineralised material, at the expected size distribution of saleable ore (-30 mm). The material drained well and the heap drained to about 3.8% moisture.

An analysis of the drainage water was performed, and the results are presented in Table 4.

Analyte	Units	Wash Water	Drainage - Week			Comments
			1	2	3	
Suspended solids	% w/w	0	0.74	0.26	0.28	Some fine, loose material releases
Calculated TDS (from EC)	mg/L	392	2110	2180	910	Some salts do wash out into water
Total Hardness as CaCO <sub>3</sub>	mg/L	392	1750	1930	564	
Total Alkalinity as CaCO <sub>3</sub>	mg/L	131	27	41	86	pH dependant
Sulfate	mg/L	12	1550	1640	361	Some reactive sulphide minerals
Chloride	mg/L	113	242	240	130	Naturally soluble salt
Sodium	mg/L	68	120	142	94	Naturally soluble salt
<b>Dissolved Metals</b>						
Cobalt	mg/L	<0.00 1	1.05	0.617	0.136	Some leaching occurs
Copper	mg/L	0.062	0.495	0.071	0.025	The reactive sulphides may be copper minerals
Manganese	mg/L	<0.00 1	7.86	5.47	1.48	Some leaching occurs

**Table 4 – Drainage Analysis Summary**

The solution analyses show that some metals are leached from the ore, probably from oxidation of some sulphide mineralisation, as would be expected.

There were some very fine particles that flowed with the water out of the pile, so some settling pond or tank facility should be considered within the port drainage structures.

Copper levels within the drainage commence at 0.495 mg/L (likely surface mineralisation) and fall to 0.025 mg/L in a short timeframe. At 0.495 mg/L copper content this is below World Health Organisation (WHO) recommended limits. WHO (1998) recommends a limit of 2 mg/l Cu to prevent

adverse health effects from copper exposure. The US Environmental Protection Agency (USEPA) developed a health-based action level of 1.3 mg/l Cu in drinking water (USEPA, 1991) and an aesthetic-based standard of 1 mg/l Cu.

### Mining

The FS is based on a conventional pit where the ramp system spirals down to the bottom of the pit and all waste is stockpiled on external waste dumps, until completion of mining.

The FS is based on the production and sale of a Direct Sale Ore (DSO) product of a nominal 50% Fe content (“Product”). No upgrade of the mined product is to be carried out other than crushing, screening, and blending of the ore.

Based on a 42% Fe cut off, a head grade of approximately 50% can be expected for mill feed at the customers facility. Furthermore, this cut-off grade encapsulates the major population of Fe grades within the block model which can be reasonably assumed can be blended and treated to produce the final 50% DSO grade.

A geotechnical assessment was carried out to assess ground conditions, identify key controls on pit slope stability and determine pit slope design parameters that are appropriate to the conditions and required risk profiles for the proposed pits.

The pit designs include integrated haul ramps and have been practically designed to facilitate an achievable production schedule and address the recommended bench geometry.

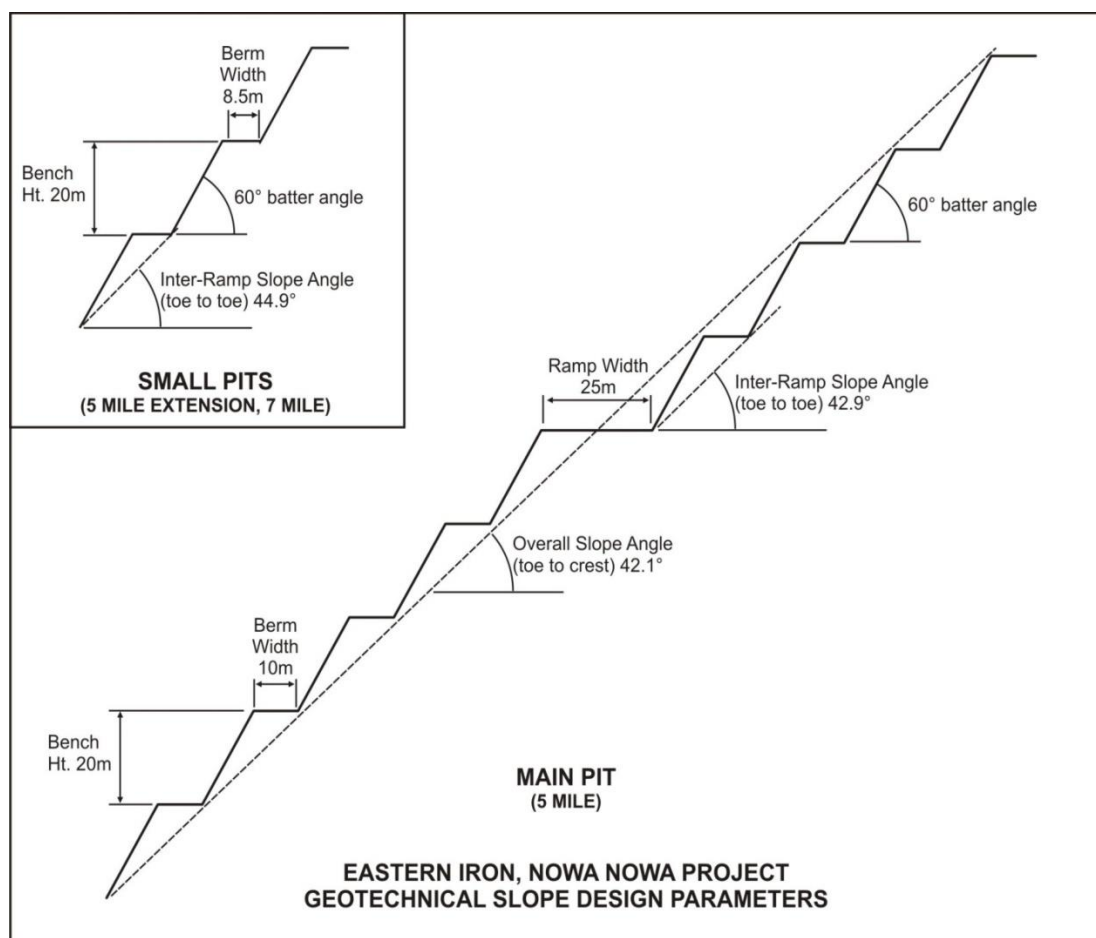

**Figure 5 – Geotechnical Slope Design Parameters**

A detailed mining schedule for the Five Mile Deposit was generated from the pit designs using the mine schedule parameters presented in Table 5 below, along with the following mining targets:

- 6 Mtpa mining rate,
- 1 Mtpa DSO production at 50% Fe grade,
- Bench advance limit of 60 m per annum in the first two years, and
- Smooth mining rate.

The schedule assumes double shifts for the first two years of mine operation, and day shift only for the duration of mine life, using a 120t excavator with 60t haul trucks.

<b>Schedule Parameters</b>	
Fe DSO Grade Target	50%
Periods Per Year, year 1 and 2	12 (Monthly)
Periods Per Year, year 3 and 4	4 (Quarterly)
Periods Per Year, year 5+	1 (Yearly)
Discount Rate	10% / year
Discount Rate/Period	0.83%/Month, 2.5%/Quarter, 10%/Year
<b>DSO Limit</b>	
Year 1 and 2	93,333 (t)/Month
Year 3 and 4	250,000 (t)/Quarter
Year 5 Onwards	1,000,000 (t)/Year

**Table 5 – Mining Schedule Parameters**

To determine the value of the project and the potential for project expansion, two separate scenario cases were analysed. The scenarios used are as follows:

- “Base” case with measured and indicated material above cut-off grade; and
- “Upside” case with measured, indicated and inferred material above cut-off grade.

The physicals from the pit schedule are presented in Table Table 6.

<b>Mine Schedule Results</b>		
<b>Pit Physicals</b>	<b>Base Case</b>	<b>Upside Case</b>
Ore Tonnes (t)	4,647,634	5,030,725
Waste Tonnes (t)	14,942,537	16,260,139
Strip Ratio	3.22	3.23
Total Tonnes (t)	19,590,171	21,290,864
Fe DSO (%)	51.75	51.43

**Table 6 – Pit Design Schedule Results**

In both cases, the DSO specifications and grade requirements are met.

For FS and for this announcement, only the base case is considered for financial information.

The overall mine layout provides for access to the ROM and waste rock facilities via the HV haul road. The width of the road would be approximately 23 m, based on the running surface being 3.5 times the width of the largest haul truck. The layout allows the haul trucks to either direct feed into the crushing plant or stockpile adjacent to the primary crusher enabling the ore to be fed into the crushing plant by FEL at a later stage.

Initial access to the pit would be from Tomato Track. Once pre-strip of the pit commenced, mine waste would be used in the construction of the HV haul roads.

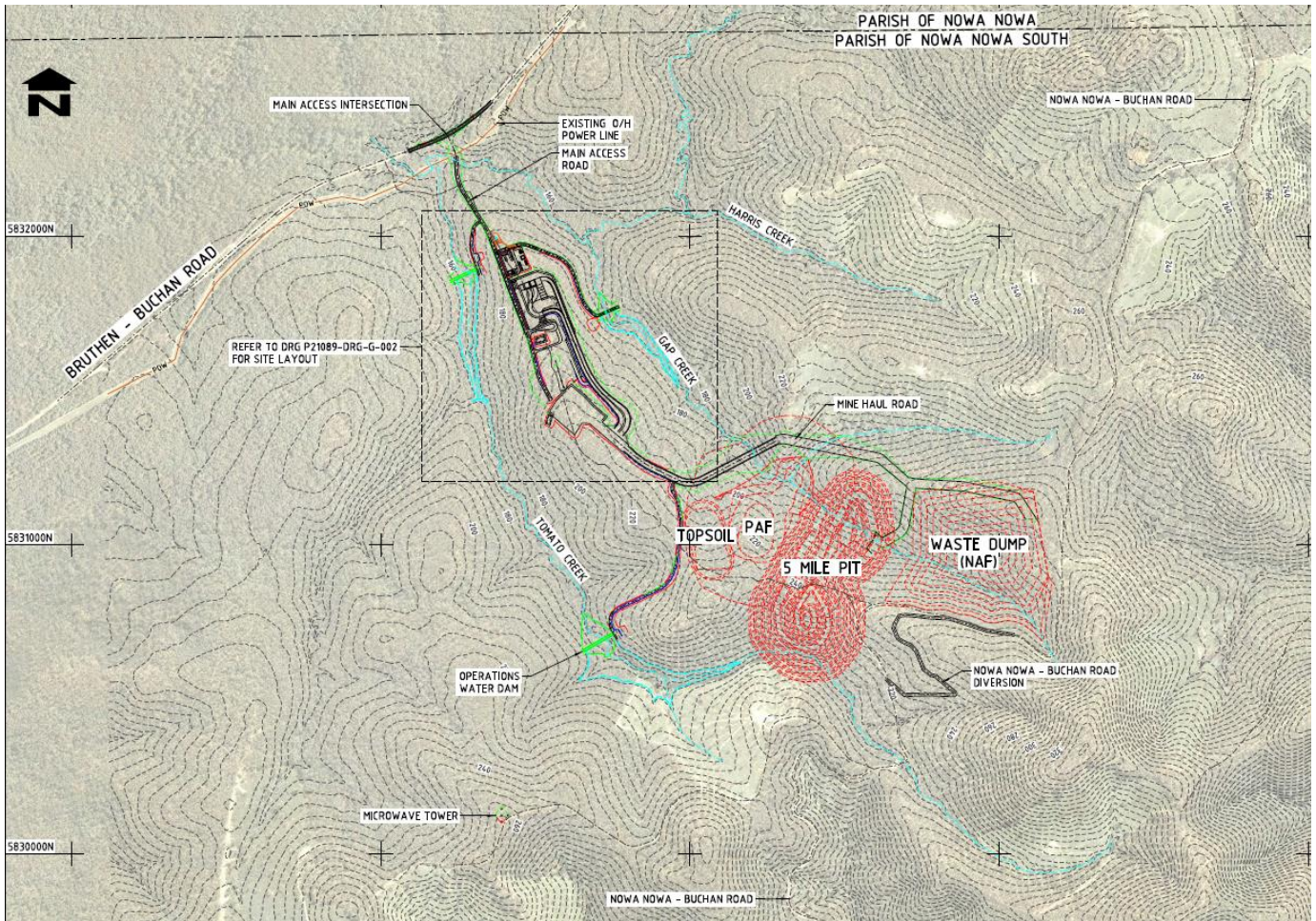

**Figure 6 – Overall Proposed Mine Layout**

**Processing**

The ore processing facility is mobile and consists of primary and secondary crushing circuit and screen to produce a single DSO product. No beneficiation is required.

A process flow diagram for the crushing plant is shown in Figure 7 and includes the following:

- ROM ore should be stockpiled at grade in several fingers by the mining fleet.
- Ore would be fed by FEL into a mobile primary crushing unit at an annualised rate of 1 Mtpa.
- Within the primary crushing module, a feeder/grizzly would direct the ROM ore to a jaw crusher. Most of the finer particles would fall onto conveyor belt CV001 below. The coarse particles would travel over the grizzly into a primary jaw crusher. Crushed ore would combine with grizzly feeder undersize on CV001 and onto CV002.
- The ore would report from CV002 to the double-deck sizing screen. Material from the top and middle decks would be directed to the secondary crusher.
- The screen undersize would be directed to CV003. The maximum particle size of the screen undersize material is 30 mm.

- Conveyor CV004 would recirculate the secondary crusher discharge to the screen feed.
- CV004 would direct the DSO product to the radial stacking conveyor. The radial stacker would be fitted with water sprays at the tail end. These sprays would moisture condition the product prior to deposition onto the final product stockpile.

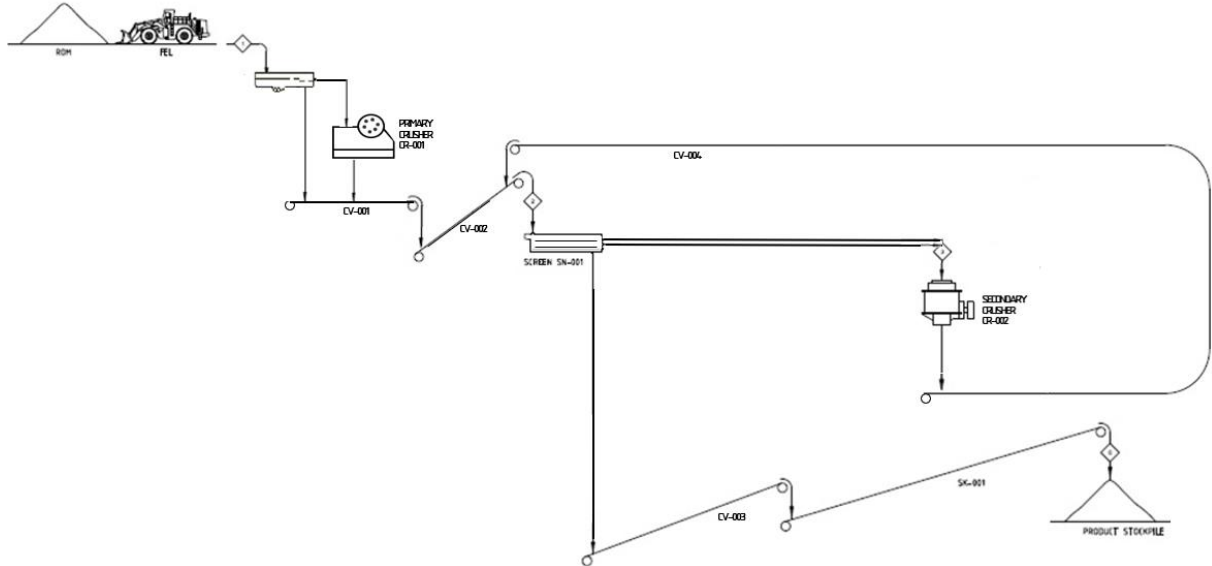

**Figure 7 – Process Flow Diagram**

## Infrastructure and Utilities

### Site Access

Site access roads include the main access road, clean water dam (CWD) access road, sedimentation control dam (SCD) access road and the operation water dam (OWD) access road.

Access into the mine is from Bruthen-Buchan Road. The main access road has been aligned on the western side of the hardstands to separate LV and HV traffic. This road would be utilised by all employees, haulage contractor trucks, deliveries and visitors entering the mine. It connects to the CWD access road, car park, SCD access road, the administration area, and crushing plant/stockyard area.

The CWD access road connects to the main access road to the CWD. The SCD access road intersects the main access road immediately after the gatehouse and direct to SCD. The OWD is designed to commence from the mine haul road near the ROM and end at OWD.

### Mine industrial area

The mine industrial area (MIA) is located between the administration area and product stockyard, which is shown in Figure 8.



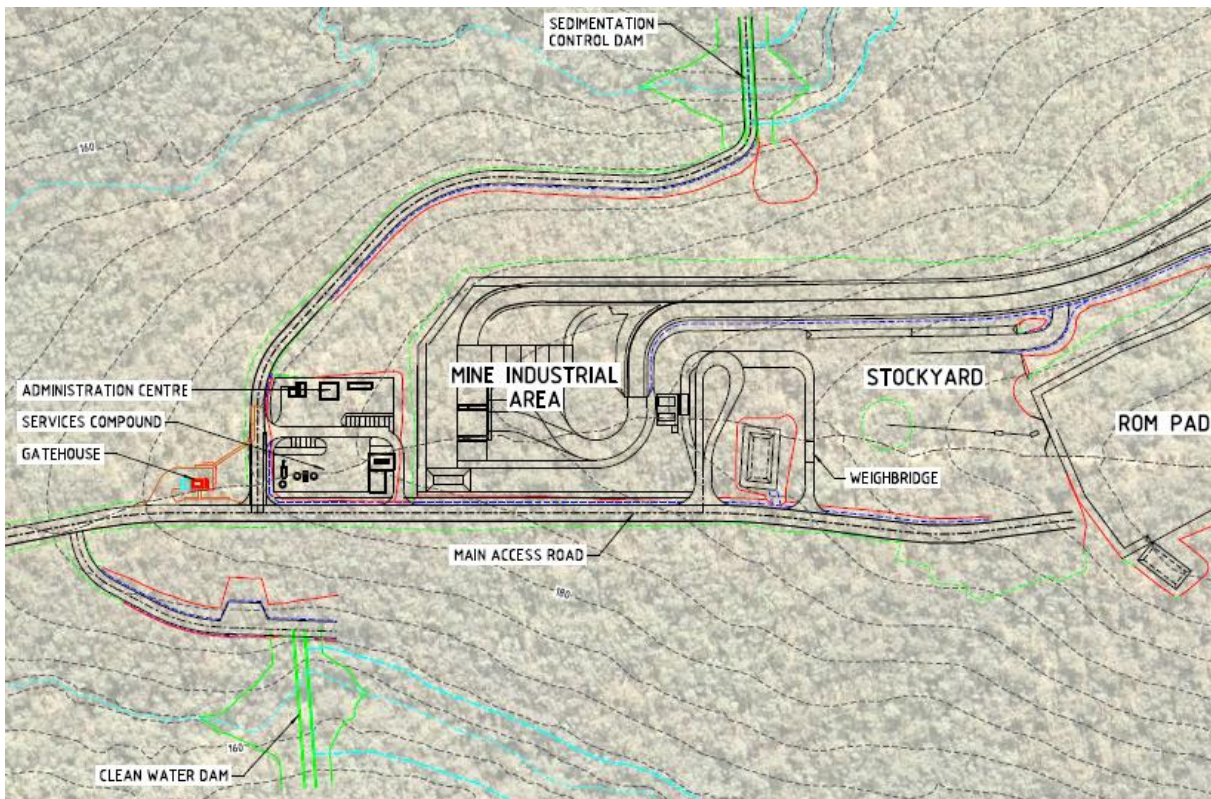

**Figure 8 – Mine Industrial Area**

The refuelling facility for the mine would be located in the MIA. The facility consists of a master self-bunded tank incorporating hoses, pumps and hand pieces for refuelling LVs and mining contractor's fuel/service truck etcetera. It also contains the necessary access and equipment for refilling the tank.

**Power**

There are two main load centres on site, the crushing plant and the administration area which includes CWD. There are also a number of remote sites where power is required, namely the go-line facilities, dewatering bores, OWD and SCD.

Diesel-fuelled generator sets would be used for power generation, and provided by the contractors.

**Water**

Three dams are to be constructed to capture site surface water runoff and facilitate mine water supply during operations. The CWD and OCD are in Tomato Creek and the SCD is in Gap Creek. All dams are classified as earth-fill dams.

Water for mining operations, ore conditioning and dust suppression will be source from the two main sources of water supply being surface water captured by dams and groundwater where local bores to be located within the Exploration Licence, which have demonstrated the potential to provide sufficient water for construction and mining operations.

## Logistics

The recommendation for product logistics as presented in the 2014 FS was to utilise road haulage from the mine to ANWE's port in Eden (Edrom). The mode of transport and the route presented in the 2014 FS has remained unchanged and is still the preferred outcome in 2021.

DSO product would be stacked at the stockyard and the haulage contractor would reclaim via FEL and load the trailers.

It is proposed that product is transported approximately 234km from the mine to the port along the existing road network utilising road haulage trucks. B-double trucks hauling are considered for approximately 46 tonnes of product per trip.

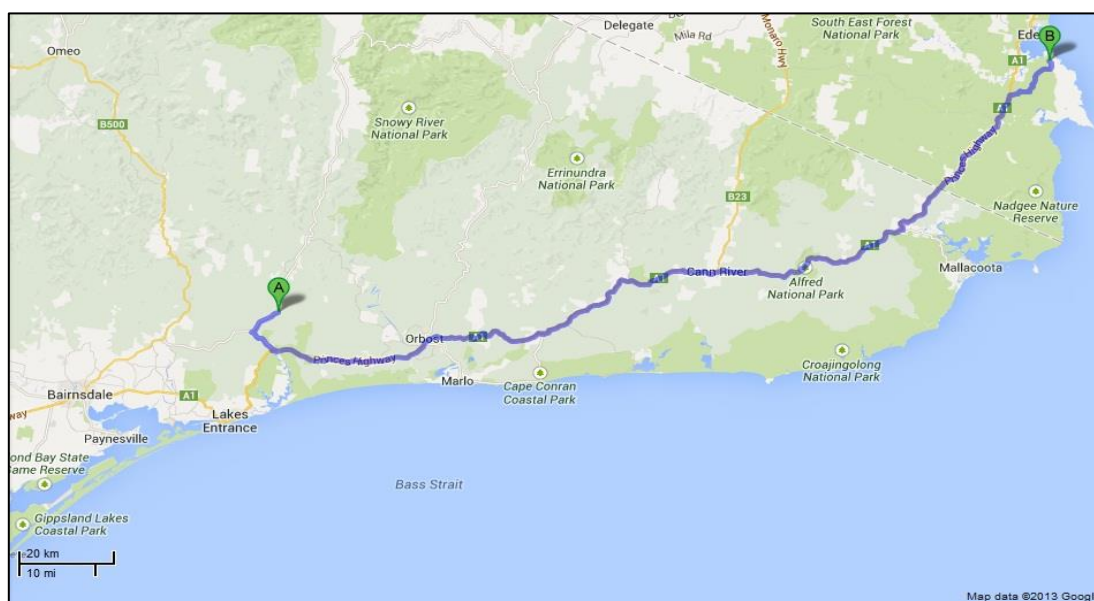

**Figure 9 – Route Overview (Google Maps)**

Road haulage is proposed to be a contractor managed operation. The haulage contractor would have one FEL at the mine for product loading and the operators would use the Company's facilities (office and ablution), with fuel for the FEL available at the site fuel farm. At the port, ANWE has indicated the haulage contractor could make use of their weighbridge, fuel farm and facilities (e.g. ablutions).

### Port of Eden

The decision to export product through ANWE's materials handling and export facility located in Edrom, NSW, has not changed from the 2014 Study. The existing port offers the most practical, timely and cost effective product export solution at the time of reporting.

The Port of Eden is located at Jews Head on the south-eastern corner of Twofold Bay, Edrom, NSW. ANWE currently has stockpile and throughput capacity for proposed production rate of 1.0Mtpa for the Project.

It is envisaged that an average of 12 - 14 shipments of ore per year will be undertaken, each with a cargo of approximately 70 kt to 80 kt. The shipments will be scheduled to enable the export of the targeted 1.0 Mtpa of production.

Haulage trucks travel to the unloading facility and unload the Product at stockyard. Product will be reclaimed at 1,200 tonnes per hour utilising dozers into the existing reclaim pit and from here the material is conveyed to the existing wharf conveyor and into the existing ship loader. Management of the stockpiles would be under ANWE's control, including reclaiming for ship loading activities.

The Company executed a MOU with Pentarch Logistics Pty Ltd, the operator of the port facilities, to export the Product using the port facilities at the Port of Eden. High level assumptions have been made regarding the product discharge and stacking, including no civil works are required along the transport route of the B-doubles, no drainage works are required along the transport route or at the stockyard, adequate capacity for a stockpile for storage of the Product.

The existing materials handling equipment would be utilised for the reclaiming of ore, with some minor modifications detailed following.



**Figure 10 – Stockyard Location**

## Environmental

Specialist studies have been undertaken, including Environmental Management Plan, Stakeholder Engagement Plan, Evaluation of Project Alternatives, Surface and Ground Water Baseline and Assessment, Environmental Geochemical Assessment of Waste and Ore, Nowa Nowa Iron Project Traffic Impact Assessment (TIA), Flora, Fauna and Ecological Characteristics and Assessment, Aquatic and Wetland Ecology Desktop Study, Aboriginal Cultural Heritage Management Plan, Land and Water Use Study, Socioeconomic and Health Baseline and Evaluation, and Air Quality, Noise and Vibration Study and Monitoring Plan. A review and update to comply with the latest regulations has been and will be undertaken.

Those studies and other required studies will be incorporated into the preparation of the Environment Effect Statement for the Project when they are completed.

## Cultural Heritage

The Gunaikurnai Land and Water Aboriginal Corporation (GLaWAC) is the sole Registered Aboriginal Party (RAP) for the mine site area.

The Company commenced preparing a Cultural Heritage Management Plan (CHMP) to comply with the *Aboriginal Heritage Act 2006* and former *Aboriginal Heritage Regulations 2007* (CHMP no. 12547). The standard assessment (surface survey) component of the CHMP was completed and

the Cultural Heritage Advisor completed an interim report entitled *5 Mile Deposit Area: Aboriginal Cultural Heritage Management Plan Interim Report*. A review and update to comply with the *Aboriginal Heritage Regulations 2018* will be undertaken.

Two Aboriginal sites were identified in the vicinity of the mine site, which would require management as part of the Project. Both are Aboriginal campsites represented by scatters of stone artefacts located on ridge tops in the vicinity of the confluence of Harris, Tomato and Gap creeks. However, only one of these sites is likely to be impacted by the Project due to the mine access road (close to the Bruthen-Buchan Road).

No Aboriginal sites or artefacts have been identified in other surveyed areas of the mine site.

Management of European historic sites is not required for the Project as no such sites have been recorded in the vicinity of the mine site or immediate surrounds. No significant direct or indirect impacts on European historic sites are expected from the Project.

## **Approvals & Permitting**

The Company has engaged and will be engaging external consultants for the key approvals/permits as follows:

### **Regulatory Approvals – the Project**

- Environmental Effects Statement (“EES”) process;
- grant of a Mining Licence and Work Plan;
- Native Title Agreement (NTA);
- approval from SRW for ‘take and use’ of surface water, works licence for dam construction, and groundwater extraction;
- approval from East Gippsland Catchment Management Authority for licencing works on waterways;
- permits for the removal of native vegetation and/or fauna on public land’;
- approval of a CHMP; and
- approval for the use of the land.

The EES process is coordinated with the above approvals and assessment requirements, in that relevant applications and statutory documents are prepared in conjunction with the EES and are placed on public exhibition together.

### **Regulatory Approvals – Port**

- Environmental Impact Statement (“EIS”), which would likely be assessed and determined by the Bega Valley Shire Council;
- Statement of Environmental Effects (“SEE”) and development consent for existing stockpile and possible new storage facilities may be required, which is determined by the Bega Valley Shire Council;
- minor modifications on the existing Environment Protection Licence (the “EPA Licence”) may be required;
- approval from Forestry Corporation for the use of Edrom Road for truck movements associated with the delivery of ore to the site, and
- any approvals associated with the use of the Port of Eden and shipping to international markets.

## Capital Costs and Operating Costs

### Capital Cost Estimate

Estimated capital costs have been broken down into the main areas required to support the mining, processing, logistics and port operations. It encompasses development capital costs to be expended from the commencement of the Project execution phase through to completion of the facilities commissioning and commencement of operations.

A broken down of capital cost estimate for the Project is presented at a summary level in Table 7.

WBS		Costs (AUD \$)
	<b>DIRECT COSTS</b>	
10000	Mine	2,870,281
20000	Crushing Plant and Materials Handling	2,047,879
30000	Product Transport and Logistics	1,805,492
40000	Port	226,646
50000	Infrastructure and Head Works	3,899,627
60000	Road Use Levy	450,000
	<b>TOTAL DIRECT COSTS</b>	<b>11,299,924</b>
	<b>INDIRECT COSTS</b>	
70000	Owner's Costs	2,523,906
80000	EPCM	1,897,717
	<b>TOTAL INDIRECT COSTS</b>	<b>4,421,623</b>
	<b>TOTAL</b>	<b>15,721,547</b>

**Table 7 – Capital Cost Estimate Summary**

### Scope of Capital Estimate

#### Direct Costs

The direct capital costs include the following:

- Mine:
  - HV and LV access roads from the ROM to Five Mile pit and the WRD;
  - MIA earthworks;
  - mining contractor mobilisation and establishment of facilities including the HV workshop, fuel farm, vehicle wash down and stores;
  - dewatering infrastructure and pipeline; and
  - Nowa Nowa-Buchan Road diversion.
- Crushing plant and materials handling:
  - ROM and stockyard earthworks;
  - crushing plant facilities;
  - grade control equipment; and
  - crushing plant services including provision of water and communications.
- Product transport and logistics:

- construction of the main access road;
- installation of a weighbridge; and
- construction of main access road intersection on Bruthen-Buchan Road.
- Port:
  - Minor modifications to the materials handling equipment; and
  - Road user levy.
- Infrastructure and headworks:
  - gatehouse and administration centre earthworks;
  - OWD, SCD, CWD and individual access roads;
  - EFE administration facilities; and
  - administration facility services including water and communications.

### **Indirect Costs**

The indirect capital costs include Owner's costs, EPCM costs and contingency.

### **Owner's Costs**

Owner's costs cover the owner's site facilities, utilities, management, and expenses throughout the construction phase. The results were comparable and equate to approximately 4% of the direct costs. Owner's costs also include an allowance of \$1,996,000 upfront for the rehabilitation bond which was calculated using the Government rehabilitation bond spreadsheet. This allowance will be reviewed to ensure compliance with obligations.

### **EPCM Costs**

EPCM Costs include the costs for head office and site office services for the execution of the Project, including engineering design, procurement, construction supervision, cost control and other administrative costs incurred as part of execution activities. Costs were developed from first principles and compared to typical costs for projects of similar size and complexity and final operating model approach.

### **Contingency**

A contingency analysis was completed in the form of a risk assessment focusing on engineering quantities and pricing. The overall outcome from this analysis provided a project contingency of 15%.

### **Quantity Development**

All equipment quantities and material take-offs were prepared on a WBS basis and provided for incorporation into the capital cost estimate.

### **Unit Rate Development**

Unit rates for the capital cost estimate were received from suppliers and contractors in the form of budget pricing. Engenium's standard commodity rate library and rates database were used where necessary and as a basis for comparison.

### **Capital Cost Estimate Qualifications**

Costs that are excluded from the capital cost estimate and typically considered as part of the financial modelling include:

- pre-strip of waste,
- escalation costs,
- sustaining capital,
- royalties and taxes, and

- native title compensation.

### Operating Cost Estimate

The operating cost estimate for the Project (FOB basis) is presented at a summary level in Table 8.

Area	Description	Costs (AUD \$/con.)	% of Total
A	Mining	15.01	20.8
B	Processing	3.48	4.8
C	Logistics	39.35	54.6
D	Port	7.86	10.9
E	Indirects	3.59	5.0
	C1 Operating Costs	69.28	96.2
F	Royalties	2.72	3.8
	Total Operating Costs (FOB)	72.00	100.0

**Table 8 – Operating Cost Estimate Summary**

The costs presented above are annualised average costs and do not reflect the variation in production levels as presented in the mining schedule.

### Scope of Operations Estimate

The operating cost estimate includes all the costs associated with the operation of the Project facilities from extraction to ship loading.

The operating strategy used as a basis in this estimate is summarised as follows:

- engage a mining contractor for ore extraction and stockpiling at the ROM pad;
- engage a mining contractor for crushing plant encompassing all crushing, screening, and stockpiling;
- engage a road haulage contractor for product haulage from the mine to the port;
- product unloading, stockpile, reclaim, ship loading and all charges at the port; and
- miscellaneous indirects and services for the supply of operations infrastructure and support.

### Source of Cost Estimate Rates

An indication of how the rates were derived within the work areas is outlined as follows.

- Mining: data was provided by Envirocon Services (mine haulage and ancillary equipment).
- Processing: the costs were developed jointly between Mining1, Engenium and EFE, including the maintenance costs were calculated by Engenium with input from FLSmidth.
- Logistics: the haulage rate was taken from service provider's budget pricing, main access road maintenance costs supplied by Whelans Group Investments and Forestry Corp NSW supplied the indicative Edrom Road levy cost.
- Shipping: the port handling rate was provided by EFE with input from Pentarch, and the maintenance costs calculated by Engenium.
- Indirects: rates were sourced from various suppliers, Engenium and EFE as per below:
  - labour rates and on-costs were developed jointly between Engenium and EFE;

- housing costs were derived from assessing suitable houses available for rent in the region at the time of writing the FS;
- LV costs were obtained from Fleetpartners, registration costs from VicRoads and insurance costs estimated by Engenium;
- communication costs are based on microwave communication provided by IT Connectivity;
- waste and wastewater costs were generated by Engenium using historical data;
- cleaning costs were estimated by Engenium and EFE;
- potable water supply costs were generated by Engenium;
- unit rates for mains power were provided by AGL to Engenium;
- fuel burn figures were generated by Engenium with fuel costs supplied by Shell;
- insurances were estimated by EFE;
- maintenance costs were calculated by Engenium; and
- other indirects were estimated by Engenium and EFE

The following items are specifically excluded from the operations cost estimate and are typically included within the financial model:

- water (for dust suppression) and power at the port is included in the handling charge;
- shipping costs;
- escalation costs;
- mining lease costs;
- regulatory and license costs;
- project finance costs;
- amortization, depreciation, financing and accounting effects;
- legal costs; and
- equipment replacement costs (i.e. sustaining capital costs).

## Financial Analysis and Market Analysis

### Financial Metrics

The base index selected for the Project valuation assessment is the Platts Iron Ore Index (IODEX) with 62% iron.

A per dry metric tonne unit (DMTU) price was calculated utilising the average base index of US\$100.5 per tonne (62% Fe Fines, delivered CFR China) over the life of the Project, with the iron ore price assumption based on the price forecast from The World Bank (21 October 2021).

The sale price per tonne for the DSO product produced from the Project (52% Fe lump, delivered CFR China) has been calculated based on the DMTU price over the life of the Project, utilising forecasted exchange rate and expected Fe grade, from the mining schedule.

The following are the assumptions relating to the financial model:

- feed rate of ROM ore is as per the Mining One base case mining schedule, with 4.65Mt product over the LOM;
- mass recovery 100% DSO;
- life of mine (LOM) of approximately 6 years;



- forecast iron ore price US\$120/tonne (62% Fe basis) in Year 1 to US\$90.04/tonne (62% Fe basis) in the final year of operation;
- average shipping costs over the LOM from the Port of Eden to North China ports US\$13/tonne
- forecast exchange rate 0.75 AUD/USD in Year 1 to 0.70 /USD in the final year of operation;
- no escalation;
- 2.75% royalty rate on total revenue minus costs of haulage, port, shipping and indirect costs;
- 0.8% Native Title royalty on total revenue minus costs of haulage, port, shipping and indirect costs; and
- 1.0% vendor royalty on gross revenue; and

### Discounted Cash Flow Analysis

A discount cash flow (“DCF”) model was used to derive a net present value (NPV) for the Project. The assumptions used in the financial model were:

- discount rate of 8%,
- Model over Project life of 6 years,
- no terminal value has been added to the NPV reflecting any extension to the mine life, and
- sustaining capital of 2.5% of direct capital spread over the LOM from year 2 onwards with \$1.3M allowance in the final year for rehabilitation and closure.

The pre-tax NPV, internal rate of return (IRR) and nominal payback period are presented in Table 9.

Pre-Tax NPV (AUD \$M)	Pre-Tax IRR (%)	Pre-Tax Payback (Years)
61.94	11.8	2

**Table 9 – Discounted Cash Flow Analysis Summary**

### Sensitivity Analysis

A sensitivity analysis on the financial model highlights that the Project value is most sensitive to capital costs, operating costs, exchange rate and the iron ore price.

For example, a 10% movement in the iron ore price impacts the Pre-Tax NPV by approximately A\$34 million.

A visual summary of the sensitivity analysis of 10% movements to capital costs, operating costs, exchange rate and iron ore price are shown in Figure 11.

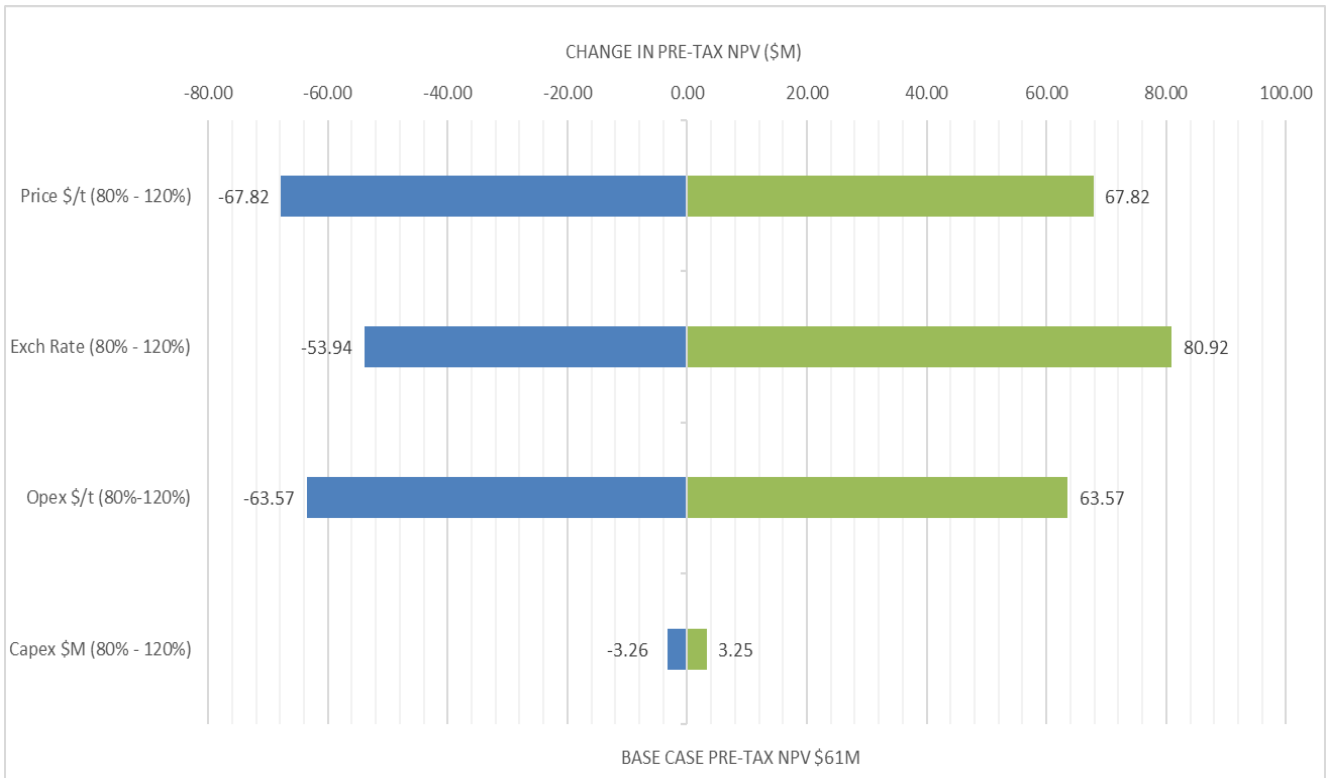

**Figure 11 – Sensitivity Analysis Tornado Chart**

## Market Assessment

The World Steel Association forecasts that steel demand will grow by 4.5% in 2021 to reach 1,855.4 Mt after 0.1% growth in 2020. In 2022, steel demand will see a further increase of 2.2% and reach 1,896.4 Mt. The current forecast assumes that, with the progress of vaccinations across the world, the spread of variants of the COVID virus will be less damaging and disruptive than seen in previous waves. These forecasts are likely to be supportive of demand growth for iron ore.

## Project Financing

EFE has been successful in raising funding to-date for its exploration and development activities to progress the Project. The Board has a track record in developing resource projects and believes that the feasibility study demonstrates the Project's potential to deliver a favourable economic return.

The outcomes delivered by the 2021 feasibility study provide confidence to the Board in the ability of EFE to secure funding for the next stage of development through conventional mining project financing methods, acknowledging the normal risks of capital raising, including the state of the equity capital and debt market, approvals required to advance the Project, and the price of iron ore.

It is anticipated that project finance will be sourced from a combination of equity and debt instruments from existing shareholders, new equity investment, product offtake parties and debt providers from Australia and overseas. EFE believes that its funding opportunities will be improved at the completion of the receipt of all necessary permits and approvals, along with commercial contracts secured with service providers and offtake partners.

Discussions are ongoing with multiple potential offtake parties and customers. While EFE has not yet made any firm binding commitments, discussions with several parties are advanced.

## Opportunities

The Company is studying further opportunities to enhance the value of the Project, include the potential as follows:

- Extending the LOM by upgrade existing inferred resources in Five Mile deposit to measured resources;
- Exploration upside based on area of Seven Mile project where iron ore have been identified;
- Increasing the production rate materially to 1.5Mtpa;
- Improvements in operational efficiencies and reduction of operating costs
- Project partnership arrangement.

## Risk

The key risks identified for the Project include:

- A significant strengthening of the Australian currency against the US currency;
- A significant decline in the iron ore price from the forecasted price in the FS;
- Delays in obtaining necessary approvals/permits;
- Restrictions in access to ANWE port facilities;
- Increased operating costs and shipping costs;
- Shortages in suitable staffing and contractors.

## Estimated Timeframe

The estimated key milestone dates from the preliminary project execution schedule developed for the purposes of the FS are as follows.

Activity	Milestone Completion Timing
Feasibility Study Report	January 2022
Environment Effects Studies	June 2022
Workplan Approval granted	June 2023
Execution commencement	June 2023
Operations (mining) commencement	July 2023

## Next Steps

The FS has outlined the Project's mining and operation plans, infrastructure requirements, production rate, capital costs, operating costs. It has determined that the Project is technically feasible, and on the assumptions of the FS has positive financial returns.

The Company will focus on the following additional works to advance the Project towards development:

- Infill drilling on Five Mile deposit to upgrade existing inferred resources to measured and/or indicated resources;
- Obtaining necessary approvals/ permits;

- Engagement and contract negotiations with key contractors and infrastructure providers;
- Detailed design works for on-site infrastructure and facilities, and for the modification of port facilities required;
- Engaging with potential offtake and financing partners;

For further background information about Nowa Nowa Iron Project, please refer to the Company's previous ASX announcements as follows:

- 13 October 2011: Eastern Iron Acquires Option to Purchase Nowa Nowa Iron Project
- 10 February 2012: Maiden JORC Resources of 9.47Mt at 49.1% Fe for Nowa Nowa Iron Project, Victoria
- 14 February 2012: Eastern Iron Acquires 100% Interest In Nowa Nowa Iron Project
- 6 December 2012: Scoping Study Successfully Completed at Nowa Nowa Project Victoria - Moving to Mine Feasibility Stage
- 12 June 2013: Resource Upgrade and Elevated Copper Results Reported From Drilling at Nowa Nowa Iron Project, Victoria
- 9 December 2013: Native Title Agreement Signed with Gunaikurnai People
- 23 April 2014: Mining Licence Granted For Nowa Nowa Iron Project
- 21 May 2014: Resource Upgrade at Nowa Nowa Project
- 29 September 2014: Nowa Nowa Project – Feasibility Study Results
- 21 April 2017: Quarterly Report – March 2017
- 21 October 2019: Company Update
- 20 April 2021: Feasibility Study Update Commences at Nowa Nowa Iron Project
- 11 August 2021: MOU Executed With Pentarch To Export From The Port Of Eden
- 29 September 2021: Nowa Nowa Iron Project Mining Study Delivers Encouraging Results
- 23 December 2021: Retention Licence Granted for Nowa Nowa Iron Project

### Investor Information

Further information, previous Eastern Resources announcements and exploration updates are available at the News and Reports tab on the Company's website – [www.easterniron.com.au](http://www.easterniron.com.au)

### Authorisation

This announcement has been authorised for release by the Board of Directors in accordance with the requirements of the Company's Continuous Disclosure Policy.

**Myles Fang**  
**Executive Director**  
**Phone: 02 9906 7551**

## **Competent Persons Statement**

The information in this report that relates to Exploration Results, Mineral Resources and Ore Reserves is based on information compiled by Greg De Ross, BSc, who is a Fellow of the Australasian Institute of Mining and Metallurgy and a consultant of Eastern Resources Limited and has sufficient experience which is relevant to the style of mineralisation and type of deposit under consideration and to the activity which he is undertaking to qualify as a Competent Person as defined in the 2012 Edition of the "Australasian Code for Reporting of Exploration Results, Mineral Resources and Ore Reserves". Mr De Ross consents to the inclusion in the report of the matters based on this information in the form and context in which it appears.

The information in this report that relates to the processing and Metallurgy for the Project is based on and fairly represents, information and supporting documentation compiled by Neville Dowson who is a Fellow of the Australasian Institute of Mining and Metallurgy and is an employee of Engenium now Stantec. Neville Dowson has sufficient experience which is relevant to the style of mineralisation and type of deposit under consideration and to the activity being undertaken to qualify as a Competent Person as defined in the 2012 Edition of the JORC Code. Neville Dowson consents to the inclusion in the report of the matters based on his information in the form and context in which it appears.

### **ASX: EFE**

**For enquiries on your shareholding or change of address please contact:**

Boardroom Limited GPO Box 3993, Sydney NSW 2001 Phone: (02) 9290 9600

<sup>1</sup> The Company confirms that it is not aware of any new information or data that materially impacts the information included in its ASX announcement of 21 May 2014 and that all material assumptions and technical parameters underpinning the mineral resource estimates included in this ASX announcement continue to apply and have not materially changed. The estimates included in the Company's ASX announcement of 21 May 2014 were reported in accordance with the JORC Code, 2012.

# JORC Code, 2012 Edition

## Table 1 report for Nowa Nowa Project

### Section 1 Sampling Techniques and Data

Criteria	Commentary
<i>Sampling techniques</i>	<ul style="list-style-type: none"> <li>Reverse circulation (RC) percussion drillholes were sampled over 2 metre downhole depth intervals via a sealed collar dust diverter and cyclone.</li> <li>Diamond core was sampled nominally at 2 metre composite intervals at the boundaries of lithological contacts.</li> <li>Both RC and diamond core drill samples were 3-4kg in weight and pulverised in the ALS Adelaide laboratory to produce a fused disk for ME-XRF21 spectrometry analysis.</li> <li>Diamond core from the 1950's Victorian Geological Survey (GSV) drillholes was nominally sampled by the GSV at both 5ft and 10ft intervals at the boundaries of lithological contacts and is reported in Bell, 1959 GSV Bulletin 57. EFE considers that there are no detrimental issues in the sampling procedure with regard to the resource estimation.</li> </ul>
<i>Drilling techniques</i>	<ul style="list-style-type: none"> <li>RC percussion drillholes were drilled using a 5 ½ inch (140mm) RC face-sampling buttoned drill bit.</li> <li>Diamond core drilling was drilled using triple-tube conventional wireline HQ (96mm) and PQ (122.5mm) diameter techniques.</li> <li>All EFE drillholes were drilled vertically and consequently diamond core was not orientated.</li> <li>All GSV drillholes were drilled vertically using conventional NQ (47.5mm) diameter diamond drilling methods. There is no record of the core being oriented.</li> </ul>
<i>Drill sample recovery</i>	<ul style="list-style-type: none"> <li>The sample recovery for all the EFE drillholes was excellent. RC drillhole sample recovery was determined by visual inspection of 1metre bulk samples in the field by an experienced supervising geologist. All assay samples submitted as two metre composites were weighed upon receipt at the laboratory. The consistency of these weights is monitored as part of EFE's sample QAQC programme.</li> <li>Company protocol is that if any RC percussion drillhole returns less than 70% by volume of the drill cuttings over a 10metre interval, the drillhole will be re-drilled.</li> <li>Full core recovery was achieved in the EFE diamond drillholes except in minor instances where friable zones were intersected downhole resulting in core losses, typically occurring at the start of a new drill run. These losses were considered to be insignificant.</li> <li>Recovery rates of drill core from diamond drilling are closely monitored by the supervising geologist. Should the integrity of the drillhole or representivity of the sample become compromised, the drillhole is abandoned at the supervising geologist's discretion.</li> <li>Recovery details for the GSV drillholes are not known. Historical geology logs do not document any significant core losses and EFE considers that there are no detrimental issues in this with regard to the resource estimation.</li> </ul>
<i>Logging</i>	<ul style="list-style-type: none"> <li>All EFE drillholes have been geotechnically and geologically logged by an experienced geologist for their entirety with a uniform set of company specific codes. Geological drillhole data is collected based on geological intervals as opposed to a metre interval basis.</li> <li>All data was digitally captured into purposed designed spreadsheet templates. All data is uploaded, validated and stored in the EFE company database.</li> <li>GSV drillholes were logged by Victorian government geologists. EFE has no knowledge of their qualifications or given levels of experience. As a result of twinning several of these drillholes, where there was excellent logging correlation, EFE has assumed that the data from these drillholes is valid for the resource estimation.</li> </ul>

Criteria	Commentary
<i>Sub-sampling techniques and sample preparation</i>	<ul style="list-style-type: none"> <li>• RC drillhole samples were split using a 75/25 riffle splitter mounted to the cyclone. A 3-4kg composite sub-sample was produced, with the split samples sent to ALS laboratories Brisbane and Perth for analysis. The bulk reject fraction of the sample was bagged and retained on site for storage.</li> <li>• Diamond core was cut using a core saw for composite sampling. Half-core for HQ diameter drillholes and quarter-core PQ diameter drillholes were sampled respectively. The retained fraction of drill core has been securely stored and archived on site.</li> <li>• Upon receipt at the lab, both EFE percussion rock chip and drill core samples were dried and crushed to a 70% passing at -6mm. The entire sample is then pulverised to an 85% passing at -75µm.</li> <li>• Diamond core from the GSV drillholes was split using a core saw and half-core was composited for assay analysis.</li> <li>• EFE have limited knowledge of the laboratory methods used for the GSV samples except as reported in Bell, 1959 GSV Bulletin 57 but it appears that samples were crushed, split and pulverised during their preparation. It is reasonable to assume that, as the samples were prepared by a certified independent laboratory, that industry-best analytical practices were employed at the time. As a result of twinning several of these holes, where there was excellent assay correlation, EFE has assumed that the data from these drillholes is valid.</li> </ul>
<i>Quality of assay data and laboratory tests</i>	<ul style="list-style-type: none"> <li>• EFE samples were assayed by ALS Global Laboratories Brisbane and Perth.</li> <li>• Assay samples were cast using a 12:22 flux to form a glass disk. The resultant disk is in turn analysed for the industry standard iron oxide suite of elements by XRF spectrometry. LOI values were determined using a thermogravimetric analyser system.</li> <li>• EFE collected field duplicate samples at a ratio of 1 in 15 samples throughout all drillholes. RC duplicate samples are taken in the field using a riffle splitter mounted onto the drill rigs cyclone. Diamond core duplicate samples are prepared by the laboratory every 15<sup>th</sup> crushed sample and inserted sequentially into the sample sequence for each drillhole.</li> <li>• Duplicate samples were analysed by ALS Global and triplicate QAQC samples by Bureau Veritas Mineral Laboratories Perth.</li> <li>• Certified reference materials are inserted nominally every 15<sup>th</sup> sample using internationally accredited standards.</li> <li>• Blanks are inserted at regular intervals within each batch of RC drilling samples and one per diamond drillhole to verify the cleanliness of laboratory sample preparation machinery.</li> <li>• Good reproducibility was obtained in the comparison of results from the umpire quality control programme. A minor high bias for total SiO<sub>2</sub> and Al<sub>2</sub>O<sub>3</sub> (~0.15%) and corresponding low bias for Fe (~0.15%) was present in the assay standards. These biases are considered insignificant.</li> <li>• EFE have no knowledge on the method of chemical method used by the GSV for assay analysis but it is reasonable to assume that best-practice industry standards were used.</li> </ul>
<i>Verification of sampling and assaying</i>	<ul style="list-style-type: none"> <li>• Six of the historical GSV drillholes have been twinned by EFE drilling, comprising one RC and five diamond drillholes. Twinned drillholes were used to verify the geological interpretation, confirm the assay tenor and to provide sample for metallurgical testwork. All drillhole data and assays are consistent with those from the earlier independent GSV drilling.</li> <li>• Data is captured in hardcopy format in the field before being transposed digitally into spreadsheets. Data entry self-audits are made routinely during this process.</li> <li>• All data is validated prior to and upon uploading to the company database by purpose built in-house software applications. EFE's database is compatible for use with MapInfo and Micromine software applications.</li> <li>• All EFE drillhole assay data was received from the laboratory in excel spreadsheet and pdf formats.</li> </ul>

Criteria	Commentary
	<ul style="list-style-type: none"> <li>• Victorian Geological Survey data was obtained from historical reports and digitised manually, before being uploaded to the company database.</li> <li>• Digital data for the project is stored on two separate remote computers as well as the Sydney office server which is backed up daily.</li> <li>• Hard copies of drillhole &amp; assay data, including report estimations, are kept secure in the Sydney office.</li> </ul>
<i>Location of data points</i>	<ul style="list-style-type: none"> <li>• EFE drillholes collar co-ordinates and elevations were located in the field using a handheld Garmin Map60 GPS, with an accuracy of +/- 3-5m. Following the completion of resource drilling, all drill collars were surveyed using a Trimble Differential GPS system with an accuracy of +/- 0.5m. DGPS drill collar data has been incorporated into the company database and is used for the resource estimation.</li> <li>• All data is georeferenced and projected through the Map Grid of Australia (MGA) 1994 geodatum within Zone 55.</li> <li>• All GSV drillhole collars were surveyed and documented on a local grid. Drilled in the 1950's, the location of these drill collars were reprojected and georeferenced into MGA 1994 using MapInfo software. The comparability of data between historical and current twinned drillholes is excellent.</li> <li>• EFE has produced a digital terrain model (DTM) and surface contour map from accurate levelling data that was recorded by geophysical contractors who carried out an airborne LIDAR over the prospect for EFE. The accuracy of this survey is within +/- 0.5m.</li> <li>• All EFE drillholes were vertical and as drillholes are relatively short (&lt;150m), it is assumed that any deviation would be negligible and have minimal impact on the resource estimation. No downhole surveys of drillholes were carried out..</li> <li>• EFE is not aware of any downhole surveying on the vertical GSV drillholes and assumes any effect on the resource estimation is negligible.</li> <li>• A table showing the location, dip, azimuth and depth of each drillhole was included in an announcement dated 13 June 2013.</li> </ul>
<i>Data spacing and distribution</i>	<ul style="list-style-type: none"> <li>• At the Five and Seven Mile prospects, nineteen and eight EFE drillholes were sited on the main magnetic anomalies respectively. Staggered drill-centres were nominally spaced at 25 metres across east-west cross-sections and 25 metres between drill profiles. The drill layout was designed to provide the best possible integration and validation of the historical GSV drillholes.</li> <li>• At the Five Mile prospect, six of the previously drilled GSV drillholes were twinned by EFE drilling to confirm their results.</li> <li>• EFE considers the density of drilling is sufficient to establish the degree of geological and grade continuity appropriate for the Mineral Resource Estimation and Classifications applied. Continuity of the mineralisation is strongly supported by the ground-based geophysical survey data.</li> <li>• EFE RC and diamond core samples were composited nominally into 2 metre intervals for head assay analysis.</li> </ul>
<i>Orientation of data in relation to geological structure</i>	<ul style="list-style-type: none"> <li>• The main body of mineralisation at Five Mile is almost horizontal. Drilling carried out by the GSV and subsequently by EFE was vertical to give close to true width intersections of the mineralisation.</li> </ul>
<i>Sample security</i>	<ul style="list-style-type: none"> <li>• All EFE drilling samples were collected in securely tied calico mining bags. RC and diamond samples were placed in clearly labelled polyweave and green plastic bags respectively, five at a time and secured with metal twist ties. Samples were transported, loaded onto pallets and despatched from a freight depot in Lakes Entrance to Adelaide for sample preparation. No samples were stored overnight in unsecured storage facilities.</li> <li>• Company sample despatch documentation was verified against laboratory arrival documentation upon the receipt of samples to the facility to ensure all samples were received.</li> <li>• Drill core was archived in plastic core trays on site - stacked, covered with lids and</li> </ul>



Criteria	Commentary
	<p>secured to pallets with metal strapping.</p> <ul style="list-style-type: none"> <li>• RC percussion drilling chip trays, with representative geological material from each metre interval, are archived and securely stored in a lock-up facility on site.</li> <li>• Drill core from the GSV drilling is stored in the departmental core store in Melbourne however it has been reported that there is little of the original core remaining.</li> </ul>
<i>Audits or reviews</i>	<ul style="list-style-type: none"> <li>• Eastern Resources has not sought external audits or reviews of sampling techniques used during the drilling campaigns.</li> <li>• EFE data capture protocol, sampling techniques and drilling datasets have been reviewed by H&amp;S Consultants for the resource estimation. They have all been found to be satisfactory for the resource estimation.</li> </ul>

## Section 2 Reporting of Exploration Results

Criteria	Commentary
<i>Mineral tenement and land tenure status</i>	<ul style="list-style-type: none"> <li>• The Five and Seven Mile Resources are contained within the Victorian EL006183.</li> <li>• Retention lease RL006488 over the Five Mile Deposit was granted to Gippsland Iron Pty Ltd, a wholly owned subsidiary of EFE, on 21 December 2021.</li> <li>• EL006183 covers mainly Crown Land of the Colquhoun State Forest. No access agreements with landholder are required, however, notification and approval of proposed exploration activities is sought from the Department of State Development, Business and Innovation.</li> <li>• EFE recognises the GurnaiKurnai people as the traditional custodians of the land situated on and immediately surrounding EL006183 and they are the Registered Aboriginal Party. A Project consent Deed was negotiated with the Gunaikurnai. All cultural heritage requirements have been met.</li> </ul>
<i>Exploration done by other parties</i>	<ul style="list-style-type: none"> <li>• Previous exploration at the Nowa Nowa Project was carried out by the Victorian Geological Survey (GSV), Pickands Mather, Australian Coal &amp; Gold and by Gulf Mines Ltd.</li> <li>• To the best of EFE's knowledge this exploration that led to the discovery of the Nowa Nowa deposit was conducted in a professional manner using recognised and widely accepted exploration and mining industry standards employed at that time.</li> <li>• Historical reports and results of the GSV exploration and previous explorers are available on open file in the Department of Primary Resources database.</li> </ul>
<i>Geology</i>	<ul style="list-style-type: none"> <li>• The Nowa Nowa Project is situated in the Lachlan Orogen, which extends from eastern Tasmania, through central and eastern Victoria, into New South Wales and Queensland.</li> <li>• The Silurian Yalmy Group and Devonian Snowy River Volcanics host the Nowa Nowa iron ore mineralisation. They are considered to be replacement deposits of the Iron Ore Copper Gold (IOCG) style of mineralisation.</li> <li>• The mineralisation is characterised by massive magnetite-hematite with lesser chlorite, talc/carbonates, pyrite, quartz and chalcopyrite.</li> <li>• Mineralisation at the Five Mile prospect occurs in a zone that is up to 500m in length, 150m in width and 100m in thickness. At the Seven Mile prospect, mineralisation occurs in a discrete zone approximately 100m in length, 50m in width and up to 65m in thickness.</li> </ul>
<i>Drill hole Information</i>	<ul style="list-style-type: none"> <li>• A tabulation of the drillhole information was presented in the <i>Nowa Nowa Resource Upgrade</i> announcement to the ASX on 12 June 2013 and on 21 May 2014.</li> <li>• No additional exploration results have since been reported.</li> </ul>
<i>Data aggregation methods</i>	<ul style="list-style-type: none"> <li>• A lower cut-off grade of 40% Fe has been used in the resource estimate for the Five and Seven Mile deposits. No top cuts have been applied.</li> </ul>

Criteria	Commentary
<i>Relationship between mineralisation widths and intercept lengths</i>	<ul style="list-style-type: none"> <li>Iron mineralisation at the Five Mile prospect replaces sediments and volcanic units which appear to be sub-horizontal or dip moderately to the southeast. Drillholes are drilled vertically and are assumed to be close to the true width intersection of the mineralisation. The geometry and attitude of the mineralisation is well constrained by close-spaced drilling which has also defined a bounding fault on the western side of the mineralisation. Mineralisation at Seven Mile is constrained by the current extents of drilling information.</li> </ul>
<i>Diagrams</i>	<ul style="list-style-type: none"> <li>Diagrams and schematics of the drilling information were presented in the <i>Nowa Nowa Resource Upgrade</i> announcement to the ASX on 12 June 2013 and on 21 May 2014.</li> </ul>
<i>Balanced reporting</i>	<ul style="list-style-type: none"> <li>No exploration results are reported in this release.</li> </ul>
<i>Other substantive exploration data</i>	<ul style="list-style-type: none"> <li>Ground magnetic surveys have clearly defined the limits of mineralisation at Five Mile and are used to guide drillhole targeting.</li> <li>A ground magnetics survey was conducted by Gulf Mines in 2008, using two Geometrics 856 magnetometers. Lines were run east - west with a 100m line-spacing between traverses. Infill lines at 50m spacing were used over the strongest anomalies at the Five and Seven Mile prospects. Measurements were recorded every five metres along each profile. Computer modelling and reporting of the ground magnetics dataset was conducted by geophysical consultant Steve Webster. A single tabular body was modelled to simulate the main anomaly at Five Mile. Strong magnetic field gradients at Seven Mile resulted in a complex modelled anomaly.</li> <li>Geophysical consultants Planetary Geophysics were contracted by Gulf Mines in 2009 to conduct a gravity survey at the Nowa Nowa Project. Carried out using a LaCoste &amp; Romberg Model-G gravity meter, a total of 210 stations were recorded. Computer modelling and reporting of the gravity dataset was conducted by geophysical consultant Steve Webster. The gravity models display an excellent fit with the observed data and are in agreement with the known geology and magnetic data acquired in the area.</li> <li>Metallurgical testwork has been carried out investigating appropriate methods of beneficiating the iron mineralisation.</li> <li>Wet low intensity separation (LIMS) and David Tube Wash (DTW) testwork was carried by ALS Metallurgy in Perth, WA. Drill core samples used in previous testwork were composited to produce a composite sample for the current testwork.</li> <li>Wet LIMS testwork was performed on a sample of the composite at P80 45 micron. DTW testwork was carried out on samples at P80 106, 75 and 45 micron</li> </ul>
<i>Further work</i>	<ul style="list-style-type: none"> <li>Further work at the Nowa Nowa Project is dependent on the results of the feasibility study currently being undertaken by EFE and in consideration of other commercial aspects.</li> </ul>

### Section 3 Estimation and Reporting of Mineral Resources

Criteria	Commentary
<i>Database integrity</i>	<ul style="list-style-type: none"> <li>Limited validation was conducted by H&amp;S Consultants to ensure the drillhole database is internally consistent. Validation included checking that no assays, density measurements or geological logs occur beyond the end of hole and that all drilled intervals have been geologically logged. The minimum and maximum values of assays and density measurements were checked to ensure values are within expected ranges.</li> <li>H&amp;S Consultants has not performed detailed database validation and EFE personnel take responsibility for the accuracy and reliability of the data used to estimate the Mineral Resources.</li> </ul>

Criteria	Commentary
<i>Site visits</i>	<ul style="list-style-type: none"> <li>• Site visits have been carried out by G De Ross consultants of EFE and Competent Persons for the reporting of exploration results.</li> <li>• No site visit has been undertaken by Rupert Osborne of H&amp;S Consultants, Competent Person for the reporting of the resource estimate due to time and cost constraints.</li> </ul>
<i>Geological interpretation</i>	<ul style="list-style-type: none"> <li>• Lithological units were identified with the use of geological logs from drillholes. The geological model of the Five Mile deposit is reasonably simple and integral to the resource estimation procedure with the Fe mineralisation interpreted to be replacing the limestone unit. It is however complicated by the presence of at least two faults that truncate mineralisation to the west and south of the deposit. The eastern edge of mineralisation, where it is in contact with unmineralised limestone, is assumed to be irregular and gradational. The geometry of sedimentary units and mineralisation in the northern part of Five mile is variable between sections and has therefore been classified at a lower confidence level. It is possible that unidentified faults or folds may occur in this region.</li> <li>• At Seven Mile the link between the mineralisation and the limestone unit is less convincing and mineralisation appears to be replacing volcanics. The geometry of the mineralisation is also not entirely clear although estimated resources are confined almost entirely to volumes within the bounds of drill tested material.</li> <li>• Although other interpretations are possible, the effect of alternative interpretations is unlikely to unduly alter the global resource estimates. The wireframes constraining mineralisation, external waste, and, in the case of Five Mile, the limestone unit, were used to define assays used for estimation of blocks in corresponding units.</li> <li>• A base of oxidation surface was constructed from the geological logs. The densities of blocks above this surface, which are derived from the estimated iron grades, were reduced by 7%.</li> </ul>
<i>Dimensions</i>	<ul style="list-style-type: none"> <li>• Dimensions of the estimated resources of Five Mile at a lower cut-off grade of 40% Fe are 160 to 620 m long and 7.5 to 210 m wide. The thickness of the mineralisation ranges from 2.5 to 110 m. Average dimensions are around 500 m long, 120 m wide and 40 m thick. The depth below surface to the upper limit of the resource varies from 2.5 to 140 m and the lower limit of the resource varies in depth from 65 to 200 m. Mineralisation remains open and currently untested to the east, north and south due to access restrictions for drilling equipment.</li> <li>• Dimensions of the estimated resources of Seven Mile at a lower cut-off of 40% Fe are 90 m long and 7.5 to 80 m wide. The thickness of the mineralisation ranges from 15 to 70 m. Average dimensions are around 70 m long, 65 m wide and 30 m thick. The depth below surface to the upper limit of the resource varies from 0 to 22 m and the lower limit of the resource varies in depth from 15 to 75 m. Mineralisation currently remains open in all directions until further drilling is completed at the Seven Mile prospect.</li> </ul>
<i>Estimation and modelling techniques</i>	<ul style="list-style-type: none"> <li>• The resources at Nowa Nowa were estimated using Ordinary Kriging in the Micromine software. H&amp;S Consultants considers Ordinary Kriging to be an appropriate estimation technique for the type of mineralisation and extent of data available at Nowa Nowa. At Five Mile the mineralisation is interpreted to occur as a replacement of the limestone unit. Wireframes representing the mineralised and limestone units were created. At Seven Mile a wireframe was created to represent the extents of mineralisation.</li> <li>• No check estimates were conducted in this round of estimation. H&amp;S Consultants estimated the resources of Five Mile in July 2014, June 2013 and August 2012 and the resources of both Five Mile and Seven Mile were estimated in February 2012. The resource estimates are consistent with previous estimates but a slight reduction in tonnes at a lower cut-off of 40% Fe has occurred due to the drilling of several new holes altering the interpreted location of a fault.</li> <li>• Concentrations of Fe, SiO<sub>2</sub>, Al<sub>2</sub>O<sub>3</sub>, P, S and Cu were included in the resource estimation. No assumptions were made regarding the recovery of by-products as estimated grades are unlikely to result in economic by-products.</li> </ul>

Criteria	Commentary
	<ul style="list-style-type: none"> <li>Block dimensions at both Five Mile and Seven Mile deposits are 10 x 10 x 5 m (E, N, RL respectively). Both deposits have been drilled on an irregular nominal grid of around 25 x 25 m. The average sample interval is two metres. Three progressively larger estimation search passes were employed, the first with radii of 40 x 40 x 15 m, the second with 60 x 60 x 20 m and the final pass with radii 90 x 90 x 30 m (along strike, down dip and across mineralisation respectively). Pass one used a four sector search requiring a minimum of 16 composites from at least three drill holes. Pass two used a four sector search requiring a minimum of 8 composites from at least two drill holes. Pass three used a two sector search requiring a minimum of 8 composites from at least one drill hole. Each pass used a maximum of 32 composites for estimation.</li> <li>Each element was estimated separately by Ordinary Kriging. A small percentage of the blocks were estimated for Fe grade but not the other elements as more intervals have been assayed for Fe. The SiO<sub>2</sub> and Al<sub>2</sub>O<sub>3</sub> grades for these blocks were derived from the estimated Fe grade using regressions based on the negative correlations found between Fe and SiO<sub>2</sub> or Al<sub>2</sub>O<sub>3</sub> grades. No significant correlation was found to occur between Fe and P, S or Cu grades. Blocks estimated for Fe that were not estimated for either P, S or Cu were therefore assigned average grades for the particular domain (mineralised, limestone or external waste).</li> <li>At Five Mile, assays from both the mineralised unit and the limestone unit were used to estimate blocks inside the mineralised wireframe. Assays from the limestone unit (only) were used to estimate blocks in the limestone wireframe and assays outside the wireframes (only) were used to estimate blocks outside the wireframes.</li> <li>At Seven Mile, the wireframe representing mineralisation was used as a hard boundary to estimate corresponding blocks.</li> <li>No top cutting was applied as extreme values were not significant.</li> <li>The block model was validated visually against drill hole data and compared against block models produced from previous resource estimates.</li> </ul>
<i>Moisture</i>	<ul style="list-style-type: none"> <li>Tonnages of the Mineral Resource are estimated on a dry weight basis.</li> </ul>
<i>Cut-off parameters</i>	<ul style="list-style-type: none"> <li>The lower cut-off of 40% Fe was used to maximise average grade and minimise internal waste.</li> </ul>
<i>Mining factors or assumptions</i>	<ul style="list-style-type: none"> <li>The Nowa Nowa deposits were estimated on the assumption that the material will be mined by open cut methods. Minimum mining dimensions are envisioned to be around 5 x 5 x 5 m (E, N, RL respectively). The resource estimation includes internal mining dilution.</li> </ul>
<i>Metallurgical factors or assumptions</i>	<ul style="list-style-type: none"> <li>Metallurgical testwork completed so far including DTR, dry LIMS and wet LIMS has shown that the Nowa Nowa iron mineralisation is amenable to a range of magnetic separation and beneficiation techniques to produce an upgraded and saleable iron ore product. Levels of deleterious elements SiO<sub>2</sub> and S are relatively high but can be reduced to acceptable levels during beneficiation.</li> </ul>
<i>Environmental factors or assumptions</i>	<ul style="list-style-type: none"> <li>During mining low grade mineralised rock is generated which is potentially acid forming but will be stored in the waste rock dump in such a way to as to neutralise its acid forming potential.</li> </ul>

Criteria	Commentary
<i>Bulk density</i>	<ul style="list-style-type: none"> <li>The density of the rock was measured for eight drill holes in Five Mile and one drill hole at Seven Mile. Density measurements were made, on average, every 1.6 m down hole on pieces of core averaging 25 cm in length. Efforts were made at the time of sample selection to ensure sample representivity and the high frequency of sampling reduces the impact of potential local biases. Core was air dried prior to weighing and the volume was measured using calipers to measure the length and diameter at three different locations for each sample. This technique takes into account void spaces. The fact that the samples were not oven dried prior to weighing may have the effect of overstating the density but the effect of this is likely to be negligible.</li> <li>The measured densities were compared against Fe assays and a regression calculated. The assay interval averages 2 m whereas density samples average around 25 cm in length so it was assumed that the density samples are representative of the assayed interval. The densities of the block models were then calculated using the estimated Fe grade and the regression between Fe grade and density. The densities of blocks above the base of oxidation surface were reduced by 7% following assessment of the relative densities of weathered rock from Nowa Nowa.</li> </ul>
<i>Classification</i>	<ul style="list-style-type: none"> <li>The Mineral Resource estimates at Five Mile deposit have been classified according to the search pass so that blocks populated in pass one are classified as Measured, blocks populated in pass two have been classified as Indicated and blocks populated in pass three are classified as Inferred. The resources in the northern part of Five Mile and the entire Seven Mile deposit are classified as Inferred due to uncertainties in the geometry of mineralisation.</li> <li>H&amp;S Consultants believes the confidence in tonnage and grade estimates, the continuity of geology and grade, and the distribution of the data reflect the Measured, Indicated and Inferred categorisation. The estimates appropriately reflect the Competent Person's view of the deposit. H&amp;S Consultants has not assessed the reliability of input data and EFE personnel take responsibility for the accuracy and reliability of the data used to estimate the Mineral Resources.</li> </ul>
<i>Audits or reviews</i>	<ul style="list-style-type: none"> <li>The estimation procedure was reviewed as part of an internal H&amp;S Consultants peer review and the block model was reviewed visually by EFE geologists. No audits of the Mineral Resource estimates have been completed.</li> </ul>
<i>Discussion of relative accuracy/confidence</i>	<ul style="list-style-type: none"> <li>No statistical or geostatistical procedures were used to quantify the relative accuracy of the resource. The global Mineral Resource estimates of the Five Mile and Seven Mile deposits are moderately sensitive to the cut-off grade applied. The cut-off grade applied makes tentative assumptions on the relative amounts of magnetic and non-magnetically recoverable Fe and may change following metallurgical and/or Davis Tube test work. The grades of the concentrate produced from any form of beneficiation have not been estimated as this data has not yet been produced. The global Mineral Resource estimates may also be inaccurate due to local uncertainties in the exact locations of the boundaries of mineralisation (+/-~10 m). Several of the boundaries are interpreted to be fault surfaces, the locations of which are moderately well defined. Additional drilling may alter the geometries of these fault surfaces.</li> <li>No production data is available for comparison to the resource estimate</li> </ul>