



VULCAN ENERGY

ZERO CARBON LITHIUM™

Corporate Presentation

Q1 2023



DISCLAIMER

No investment or financial product advice

This Presentation, and the information provided in it, does not constitute, and is not intended to constitute, financial product or investment advice, or a recommendation to acquire Vulcan Shares, nor does it constitute, and is not intended to constitute, accounting, legal or tax advice. This Presentation does not, and will not, form any part of any contract for the acquisition of Vulcan Shares. This Presentation has been prepared without taking into account the objectives, financial or tax situation or particular needs of any individual. Before making an investment decision (including any investment in Vulcan Shares or Vulcan generally), prospective investors should consider the appropriateness of the information having regard to their own objectives, financial and tax situation and needs, and seek professional advice from their legal, financial, taxation or other independent adviser (having regard to the requirements of all relevant jurisdictions). Vulcan is not licensed to provide financial product advice in respect of an investment in shares. Any investment in any publicly-traded company, including Vulcan, is subject to significant risks of loss of income and capital.

Forward-looking statements

This Presentation contains certain forward-looking statements. Often, but not always, forward-looking statements can be identified by the use of forward-looking words such as "may", "will", "expect", "intend", "plan", "estimate", "target", "propose", "anticipate", "continue", "outlook" and "guidance", or other similar words. Such forward-looking statements may include, but are not limited to, statements regarding: the proposed use of funds; estimated mineral resources and ore reserves; forecast financial information (including revenue and EBITDA); permits and approvals; forecast lithium prices; expected future demand for lithium products; planned production and operating costs; planned capital requirements; planned strategies and corporate objectives; and expected construction and production commencement dates.

By their nature, forward-looking statements inherently involve known and unknown risks, uncertainties and other factors that may cause actual results, performance and achievements to be materially greater or less than estimated, including those generally associated with the lithium industry and/or resources exploration companies, including but not limited to the risks listed in Appendices 10 and 11 of this Presentation as well as the risks contained in the Prospectus dated 11 February 2022, and the ASX Announcement "Vulcan Zero Carbon Lithium™ Project DFS results and Resources-Reserves update" released to ASX on 13 February 2023 and the "Risk factors" section of the Equity Raising Presentation released to ASX on 14 September 2021 (together the "**Previous Disclosures**").

These factors may include, but are not limited to, changes in commodity and renewable energy prices, foreign exchange fluctuations and general economic conditions, increased costs and demand for production inputs lithium, the speculative nature of exploration and project development (including the risks of obtaining necessary licenses and permits and diminishing quantities or grades of reserves), political and social risks, changes to the regulatory framework within which Vulcan operates or may in the future operate, environmental conditions including climate change and extreme weather conditions, geological and geotechnical events, environmental issues, the recruitment and retention of key personnel, industrial relations issues and litigation.

Any such forward-looking statements, opinions and estimates in this Presentation (including any statements about market and industry trends) are based on assumptions and contingencies, all of which are subject to change without notice, and may ultimately prove to be materially incorrect. Accordingly, prospective investors should consider any forward-looking statements in this Presentation in light of those disclosures, and not place undue reliance on any forward-looking statements (particularly in light of the current economic climate and significant volatility, uncertainty and disruption caused by the COVID-19 pandemic and the Russian invasion of Ukraine). Forward-looking statements are provided as a general guide only and should not be relied upon as, and are not, an indication or guarantee of future performance. All forward-looking statements involve significant elements of subjective judgement, assumptions as to future events that may not be correct, known and unknown risks, uncertainties and other factors – many of which are outside the control of Vulcan.

Except as required by applicable law or regulation (including the ASX Listing Rules), Vulcan does not make any representations, and provides no warranties, concerning the accuracy of any forward-looking statements, and disclaims any obligation to update or revise any forward-looking statements, whether as a result of new information, future events or results, or otherwise. Neither Vulcan nor any of its directors, officers, agents, employees or advisors give any representation or warranty, express or implied, as to the fairness, accuracy, completeness or correctness of the information, opinions and conclusions contained in this Presentation.

Investment Risks

As noted above and contained in the Previous Disclosures, an investment in Vulcan is subject to both known and unknown risks, some of which are beyond the control of Vulcan. Vulcan does not guarantee any particular rate of return or its performance, nor does it guarantee any particular tax treatment. Prospective investors should have regard to the risks in the Previous Disclosures particularly the February 2022 Prospectus and September Equity Raise Presentation, when making their investment decision, and should make their own enquires and investigations regarding all information in this Presentation, including, but not limited to, the assumptions, uncertainties and contingencies that may affect Vulcan's future operations, and the impact that different future outcomes may have on Vulcan. There is no guarantee that any investment in Vulcan will make a return on the capital invested, that dividends will be paid on any fully paid ordinary shares in Vulcan, or that there will be an increase in the value of Vulcan in the future. Accordingly, an investment in Vulcan and Vulcan Shares should be considered highly speculative, and potential investors should consult their professional advisers before deciding whether to invest in Vulcan.

DISCLAIMER

Ore Reserves and Mineral Resources Reporting

It is a requirement of the ASX Listing Rules that the reporting of ore reserves and mineral resources in Australia comply with the Joint Ore Reserves Committee's Australasian Code for Reporting of Mineral Resources and Ore Reserves ("JORC Code"). Investors outside Australia should note that while ore reserve and mineral resource estimates of the Company in this document comply with the JORC Code (such JORC Code-compliant ore reserves and mineral resources being "Ore Reserves" and "Mineral Resources" respectively), they may not comply with the relevant guidelines in other countries and, in particular, do not comply with (i) National Instrument 43-101 (Standards of Disclosure for Mineral Projects) of the Canadian Securities Administrators (the "Canadian NI 43-101 Standards"); or (ii) subpart 1300 of Regulation S-K under the US Securities Act of 1933, as amended (the "Securities Act"), which governs disclosures of mineral reserves in registration statements filed with the US Securities and Exchange Commission ("SEC").

Information contained in this Presentation describing mineral deposits may not be comparable to similar information made public by companies subject to the reporting and disclosure requirements of Canadian or US securities laws. On 31 October 2018, the SEC adopted amendments to its disclosure rules to modernise the mineral property disclosure requirements for issuers whose securities are registered with the SEC under the US Exchange Act of 1934, as amended (the "Exchange Act"). These amendments became effective 25 February 2019, with compliance required for the first fiscal year beginning on or after 1 January 2021. Under these amendments, the historical property disclosure requirements for mining registrants included in Industry Guide 7 under the Securities Act were rescinded and replaced with disclosure requirements in subpart 1300 of Regulation S-K. As a result of the adoption of subpart 1300 of Regulation S-K, the SEC's standards for mining property disclosures are now more closely aligned to the JORC Code's requirements. For example, the SEC now recognises estimates of "measured mineral resources", "indicated mineral resources" and "inferred mineral resources." In addition, the SEC has amended its definitions of "proven mineral reserves" and "probable mineral reserves" to be "substantially similar" to the corresponding standards under the JORC Code. However, despite these similarities, SEC standards are still not identical to the JORC Code. Accordingly, investors are cautioned that there can be no assurance that the reserves and resources reported by the Company under the JORC Code would be the same had it prepared its reserve or resource estimates under the standards adopted under subpart 1300 of Regulation S-K.

Disclaimer

Vulcan, to the maximum extent permitted by law, expressly excludes and disclaims all liability (including, without limitation, any liability arising out of fault or negligence on the part of any person) for any direct, indirect, consequential or contingent loss or damage, or any costs or expenses, arising from the use of this Presentation or its contents, or otherwise arising in connection with it.

Industry data

Certain market and industry data used in connection with or referenced in this Presentation may have been obtained from public filings, research, surveys or studies made or conducted by third parties, including as published in industry-specific or general publications. Neither Vulcan nor its advisers, nor their respective representatives, have independently verified any such market or industry data. To the maximum extent permitted by law, each of these persons expressly disclaims any responsibility or liability in connection with such data.

Effect of rounding

A number of figures, amounts, percentages, estimates, calculations of value and fractions in this Presentation are subject to the effect of rounding. Accordingly, the actual calculation of these figures may differ from the figures set out in this Presentation.



DISCLAIMER

Financial data

All monetary values expressed as "\$" or "A\$" in this Presentation are in Australian dollars, unless stated otherwise. All monetary values expressed as EUR or € in this Presentation are in Euros, unless stated otherwise. All monetary values expressed as "US\$" in this Presentation are in US dollars, unless stated otherwise. The assumed exchange rate to convert Euros into Australian dollars or US dollars (as applicable) is shown in the footnote to each respective slide.

In addition, prospective investors should be aware that financial data in this Presentation includes "non-IFRS financial information" under ASIC Regulatory Guide 230 'Disclosing non-IFRS financial information' published by ASIC and also 'non-GAAP financial measures' within the meaning of Regulation G under the U.S. Securities Exchange Act of 1934.

The non-IFRS financial measures do not have standardised meanings prescribed by Australian Accounting Standards and, therefore, may not be comparable to similarly titled measures presented by other entities, nor should they be construed as an alternative to other financial measures determined in accordance with Australian Accounting Standards. Although Vulcan believes the non-IFRS financial information (and non-IFRS financial measures) provide useful information to readers of this Presentation, readers are cautioned not to place any undue reliance on any non-IFRS financial information (or non-IFRS financial measures).

Similarly, non-GAAP financial measures do not have a standardised meaning prescribed by Australian Accounting Standards or International Financial Reporting Standards and therefore may not be comparable to similarly titled measures presented by other entities, nor should they be construed as an alternative to other financial measures determined in accordance with Australian Accounting Standards or International Financial Reporting Standards. Although Vulcan believes that these non-GAAP financial measures provide useful information to readers of this Presentation, readers are cautioned not to place undue reliance on any such measures.

Technical information

Vulcan has so far only carried out a pre-feasibility study (the results of which were announced to the ASX in the announcement "Positive PFS & Maiden JORC Ore Reserve: Zero Carbon Lithium™ Project" dated 15 January 2021) ('PFS') and a definitive feasibility study for Phase One of its Zero Carbon Lithium™ Project ('Project') (the results of which were announced to the ASX in the announcement "Vulcan Zero Carbon Lithium™ Project DFS Results, Resources and Reserves Update" dated 13 February 2023) ('DFS'). Vulcan has not yet carried out a definitive feasibility study for Phase Two of its Project. This Presentation includes information relating to both the PFS and DFS. Investors should not rely on the results of the PFS as Vulcan considers that the material assumptions underpinning that study are no longer up to date in light of the additional studies undertaken in preparing the DFS.

The DFS is based on the material assumptions outlined elsewhere in the DFS announcement. While Vulcan considers all of the material assumptions to be based on reasonable grounds, there is no certainty that they will prove to be correct or that the range of outcomes indicated by the DFS will be achieved.

Funding Strategy

To achieve the range of outcomes indicated in the DFS, additional funding will be required. Investors should note that there is no certainty that Vulcan will be able to raise the amount of funding when needed. It is also possible that such funding may only be available on terms that may be dilutive to or otherwise affect the value of Vulcan's existing shares. It is also possible that Vulcan could pursue other financing strategies such as a partial sale or joint venture of the Project. If it does, this could materially reduce Vulcan's proportionate ownership of the Project.

Acknowledgement and agreement

By attending an investor presentation or briefing, or accepting, accessing or reviewing this Presentation, you acknowledge and agree to the terms set out in this "Disclaimer" section of the Presentation.



COMPETENT PERSON STATEMENT

The information in this presentation that relates to estimates of Mineral Resources and Ore Reserves is extracted from the following ASX announcement:

- "Vulcan Zero Carbon Lithium™ Project Phase One DFS results and Resources-Reserves Update", released on 13 February 2023.

The above announcement is available to view on Vulcan's website at www.v-er.eu.

Vulcan confirms that, in respect of estimates of Mineral Resources and Ore Reserves included in this presentation:

- it is not aware of any new information or data that materially affects the information included in the original market announcement, and that all material assumptions and technical parameters underpinning the estimates in the original market announcement continue to apply and have not materially changed;
- the form and context in which the Competent Persons' findings are presented in this presentation have not been materially modified from the original market announcement; and
- all material assumptions underpinning the production targets (and the forecast financial information derived from such production targets) included in this presentation continue to apply and have not materially changed.





OUR TARGET: ONE MILLION

We are aiming to become the world's first integrated lithium chemicals and renewable energy producer with net zero greenhouse gas emissions.

Vulcan's unique **Zero Carbon Lithium™** Project aims to produce both renewable geothermal energy, and lithium hydroxide for Electric Vehicle (EV) batteries, from the same deep brine source in the Upper Rhine Valley, Germany.

Renewable heat
production for
more than
1 million people
by 2030¹



Enough **lithium hydroxide**
production for
1 million EVs
per annum²



1 million tonnes of
CO₂ emissions
avoided
per annum³



¹Based on average per capita heat consumption in Germany of 6,200 kWh (<https://www.destatis.de/>), and the estimated capacity for heat production from Vulcan's long term development areas, in a pure heat (no power) scenario. ²Based on Phase One production target of 24ktpa from DFS, Phase Two production target of approx. similar figure from PFS (refer to technical information statement on [slide 4](#)), and Vulcan internal estimated average EV battery size and chemistry in Europe. ³CO₂ emissions avoidance target based on Minviro LCA data on Vulcan project and lithium industry peer averages in the same LCA.

VULCAN'S RENEWABLE ENERGY AND LITHIUM CHEMICALS PROJECT

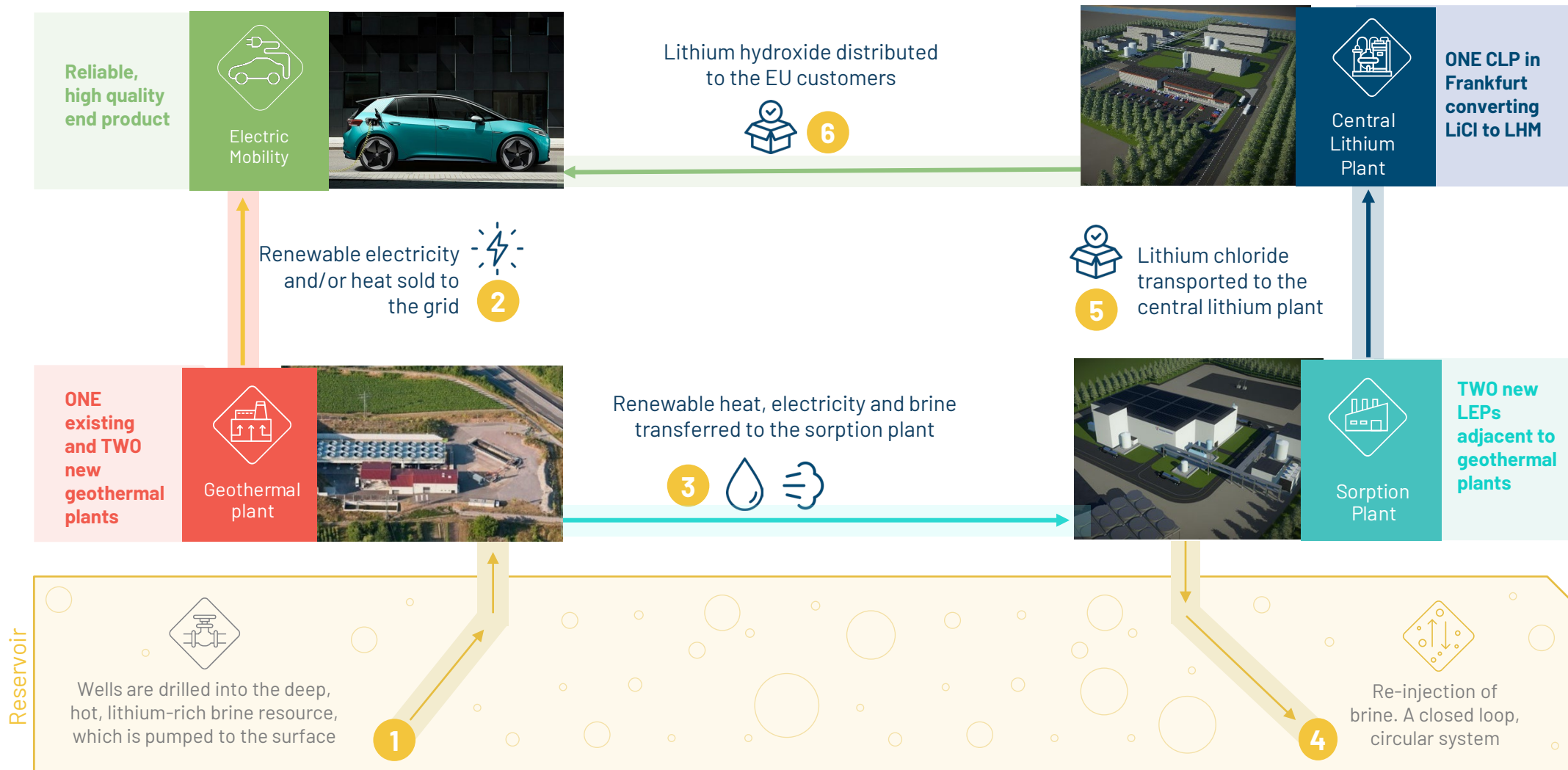

Note: LEP = Lithium Extraction Plant, CLP = Central Lithium Plant

KEY ACHIEVEMENTS H2 2021-NOW

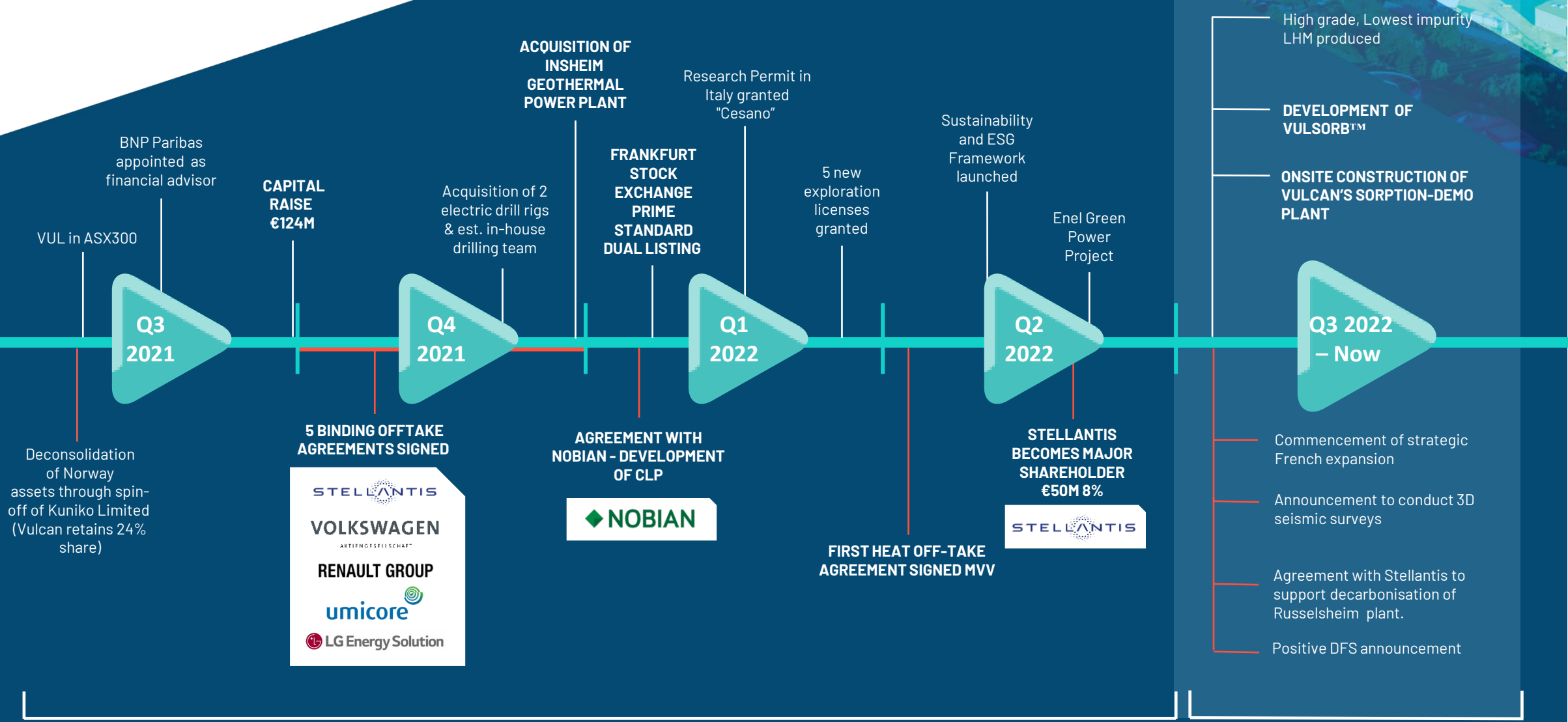

FY22 Financial Year

FY23 Financial Year

VULCAN PROJECT – PHASE ONE

Production goals:

- Target of 24,000tpa of Lithium Hydroxide Monohydrate (LHM) production¹.
- Target of >300GWh of renewable power and >250GWh of renewable heat produced each year.

Why?

- Vital project for Germany, the EU, the auto industry and the energy transition.

Where?

- In the Upper Rhine Valley Brine Field, in Rhineland-Palatine for geothermal and lithium extraction, and in Frankfurt (Hesse) for lithium conversion.

When?

- Targeted start of construction in H2 2023 (drilling to increase brine production).
- Targeted start of production in late 2025².

How?

- Growing team: ~280 personnel working for Vulcan.
- Project financing planned through debt and equity.
- Integrated execution plan using VUL expertise together with multiple experienced partner companies.



¹Based on Phase One production target of 24ktpa and 307,000MWh of power from DFS

²Start of production is a target date and will be subject to regular review depending on a number of factors including permitting and equipment supply chains. Please refer to Risk Factors slides in Appendices 6 and 7.



PROJECT LOCATION

- Large, **300km-long** graben system containing consistent sedimentary-hosted geothermal-lithium reservoir.
- Vulcan's Upper Rhine Valley Brine Field (URVBF) within its Zero Carbon Lithium™ Project, consisting of 15 licenses for a total area of 1,583 km², represents **Europe's largest lithium resource, with 26.6Mt contained LCE from 10 of its 15 licenses¹**.
- Strategically located** in the middle of the European battery industry.
- Phased growth approach**, starting from core of field where Vulcan already owns production/re-injection geothermal wells in operation.
- Phase One DFS consists of five license areas** including Vulcan's geothermal production license, in the core of the field including existing geothermal production wells.

¹According to public, JORC-compliant data

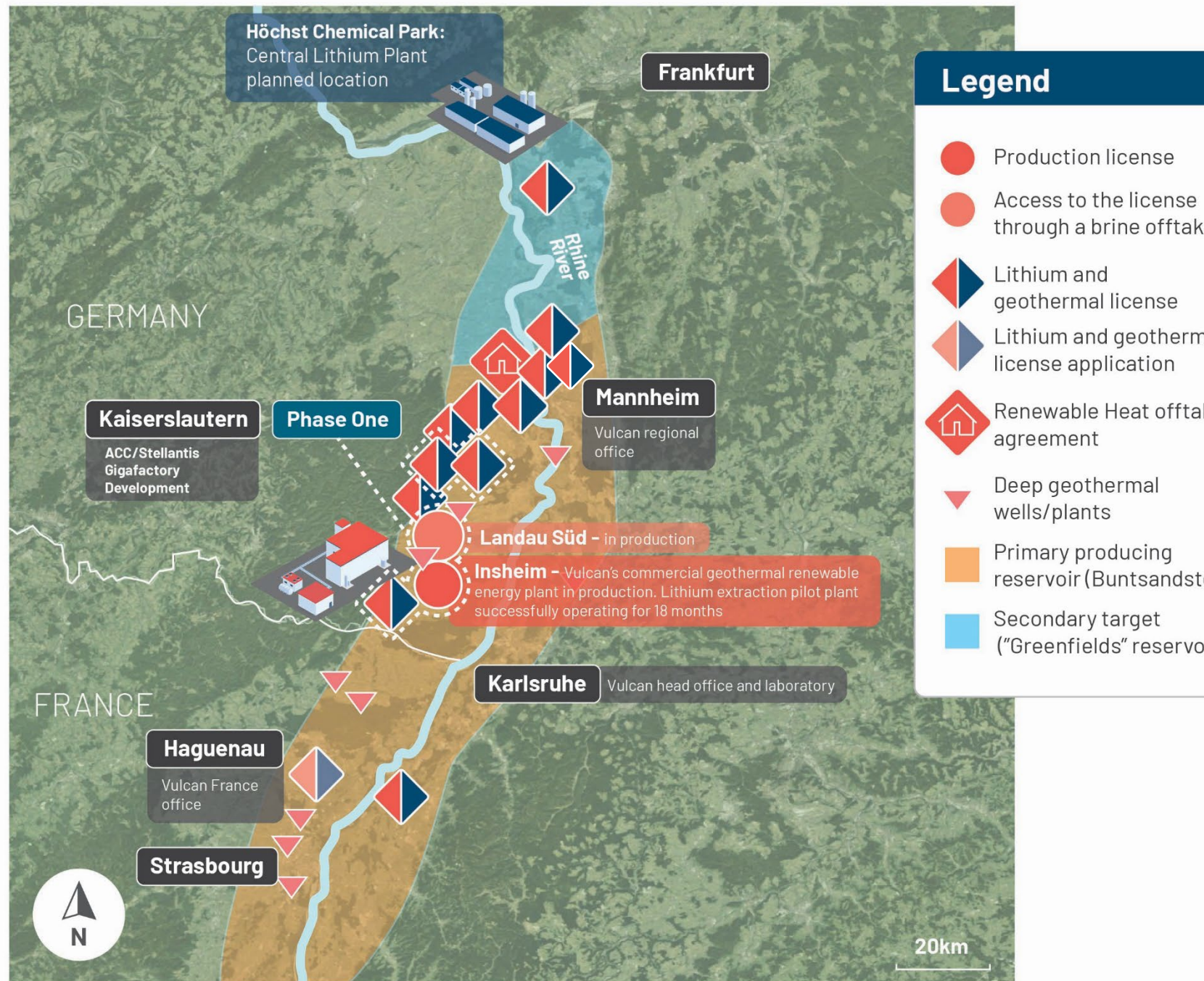

LIONHEART RESERVOIR FRAMEWORK AND PLANNED WELL PLACEMENT



Use existing production wells and add new wells to aim to achieve production/reinjection capacity of 600l/s¹ – approx. 16,000tpa LHM equivalent at SOP.

DFS focus of field development planning has been on sustainability of lithium production over time: flow rate assumptions for new wells reduced to improve “sweep” of lithium and reduce dilution: average of 75l/s per existing and planned producer.

7 Well sites (incl. 2 existing)

8 Producers (incl. 2 existing) in red

10 Re-injectors (incl. 2 existing) in blue

Total 14 new wells

¹Production figures are estimates based on existing producers and planned wells, seismic analysis, reservoir simulation and field development planning, and will need review after development well drilling is completed.

600 liters/sec

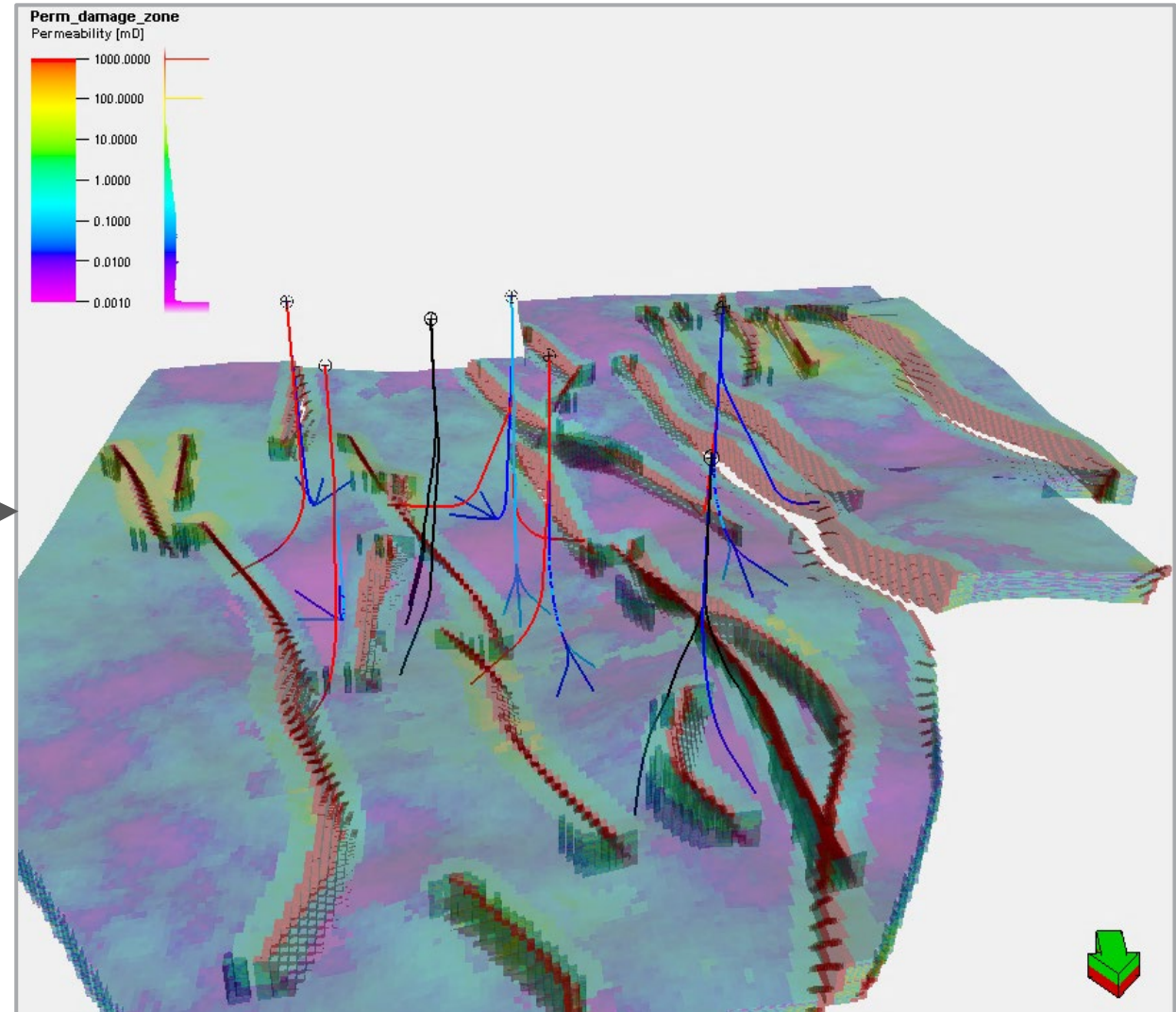

TARO RESERVOIR FRAMEWORK AND PLANNED WELL PLACEMENT



Add new wells to aim to achieve production/reinjection capacity of 300l/s¹ – approx. 8,000tpa LHM equivalent at SOP.

DFS focus of field development planning has been on sustainability of lithium production over time: flow rate assumptions for new wells reduced to improve “sweep” of lithium and reduce dilution: average of 60 l/s per planned producer.

2 Well sites

5 Producers (in red)

4 Re-injectors (in blue)

Total 9 new wells

¹Production figures are estimates based on seismic analysis, reservoir simulation and field development planning and will need review after development well drilling is completed.

300 liters/sec

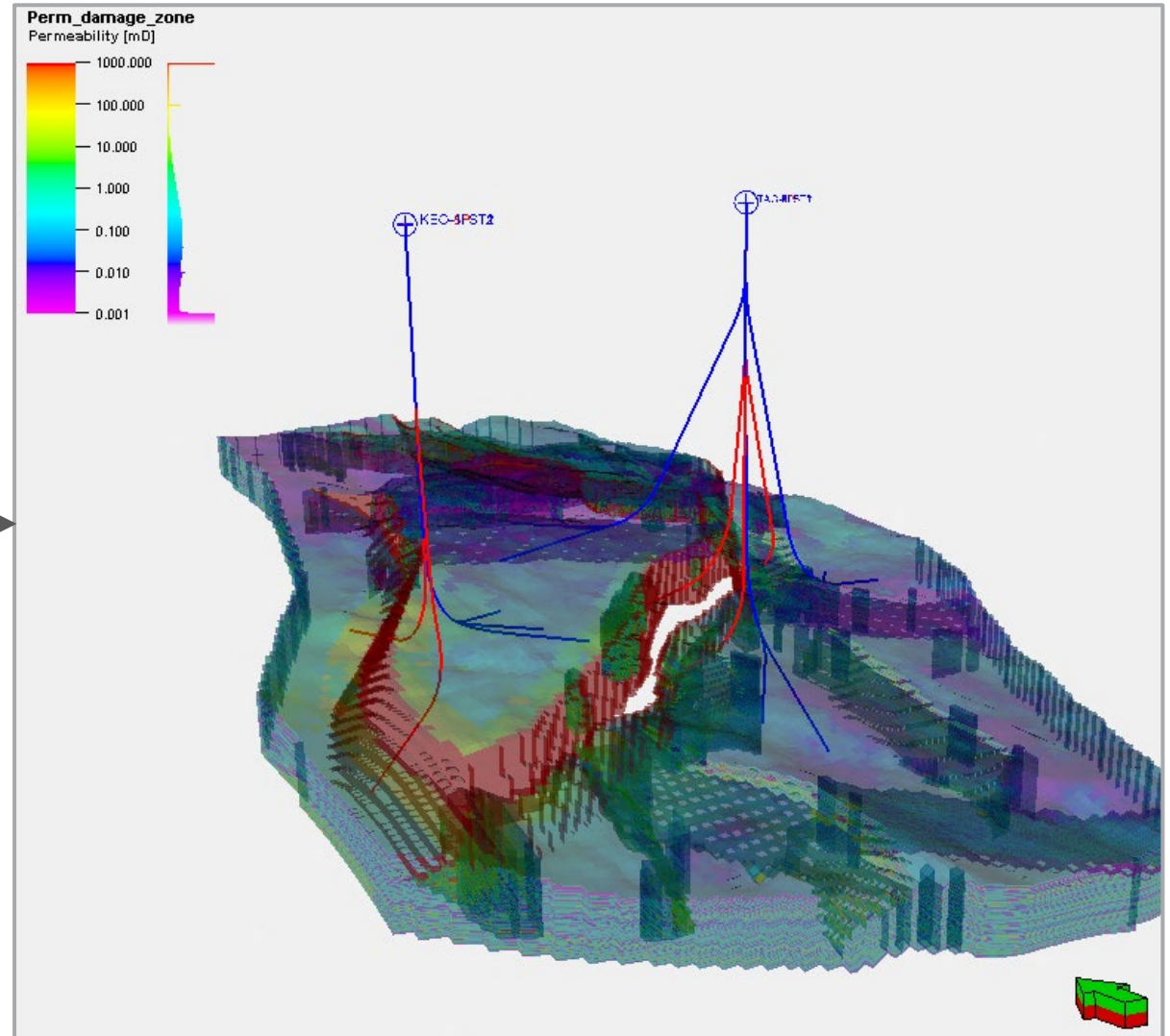

TARGET LITHIUM OUTPUT PHASE ONE – LHM EQUIVALENT

Lithium dilution at the well sites modelled over 30 years and remains above cut-off, with only ~1.6% annual grade decrease. Production levels could be increased by adding new wells in the future, not modelled here¹.

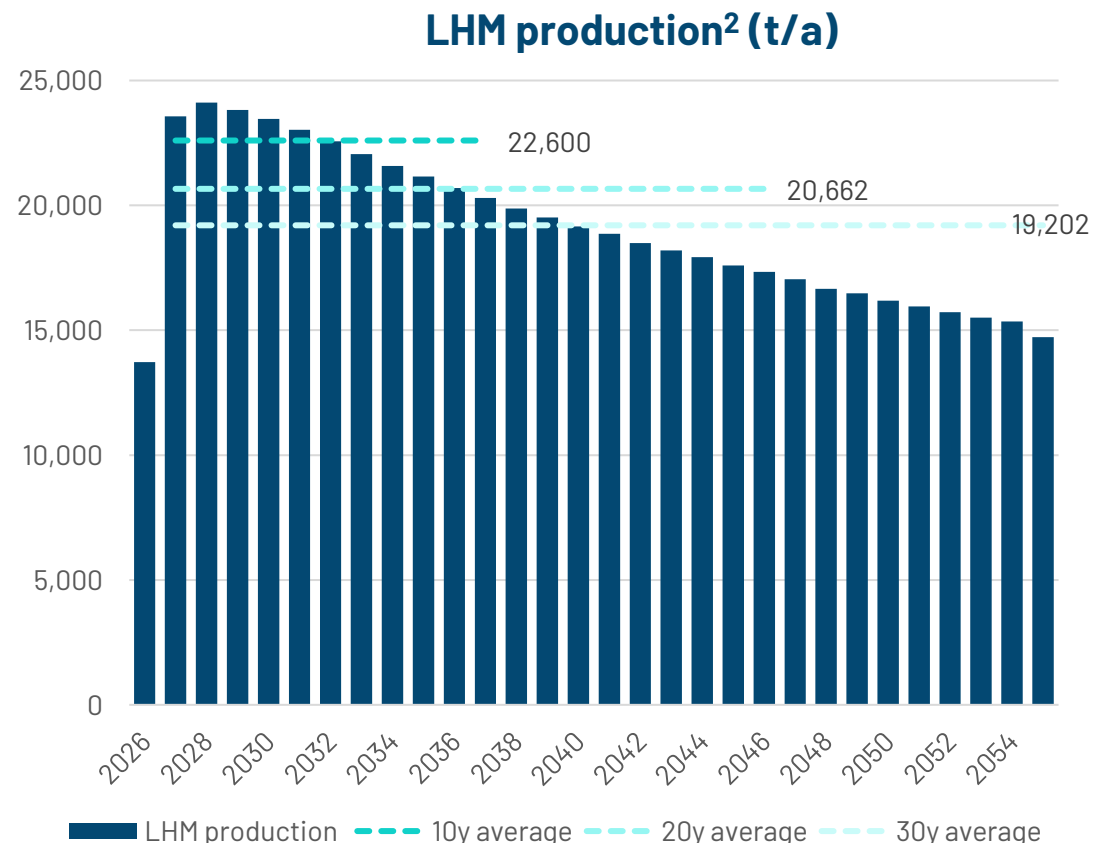
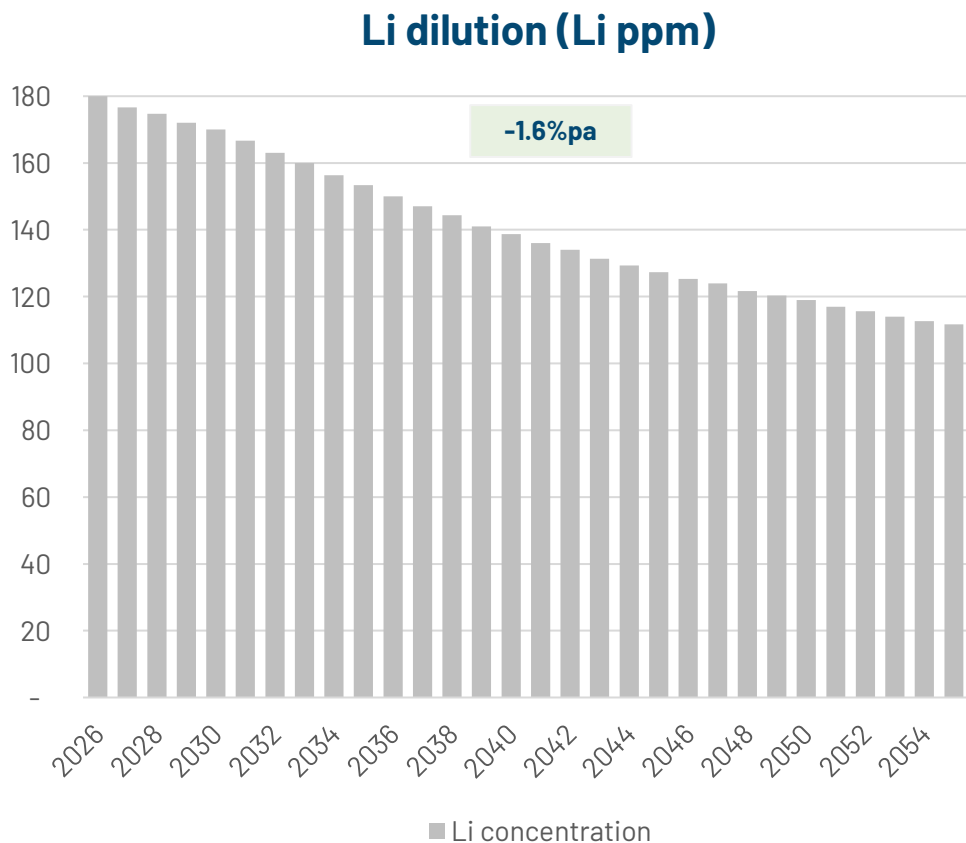

Lithium production levels could be increased by adding new wells in the future and keeping existing wells producing renewable heat only. Heat modelling shows no decrease over time.

¹Production and dilution is based on reservoir estimation, modelling and simulation, and is subject to further review as further development wells are drilled to increase brine production from Phase One area. Dilution is based on weighted average of two areas. Note: See the DFS announcement dated 13 February 2023, material assumptions on Appendix 14 of the 13 February 2023 presentation, risk factors in appendices 6 and 7 and Competent Persons Statement on slide 5.
²Output of 24ktpa is estimated as at the fully ramped up commencement of production as shown above.

DEVELOPMENT DRILLING PLAN

Vulcan has established its own in-house geothermal drilling company, Vercana, due to a high demand for geothermal drilling for renewable energy projects and tightness of rig supply. In this regard, Vulcan has also acquired two electric drill rigs, and a drilling labour contract company with a sizeable workforce to staff the rigs.

Development drilling¹ is planned to focus initially on increasing existing brine production from Lionheart field in Phase One area.

Development drilling campaign duration: 2.5 years:

- ✓ Rig 1 (owned by VUL): Lionheart - 7 wells
- ✓ Rig 2 (owned by VUL): Lionheart - 7 wells
- ✓ Rig 3²: Taro - 6 Wells
- ✓ Rig 4²: Taro - 3 Wells



Project area	Rig	2023	2024	2025					
Lionheart	RIG 1	P							
Lionheart	RIG 1		I						
Lionheart	RIG 1			P					
Lionheart	RIG 1				I				
Lionheart	RIG 1					P			
Lionheart	RIG 1						I		
Lionheart	RIG 1							I	
Lionheart	RIG 2		P						
Lionheart	RIG 2			I					
Lionheart	RIG 2				P				
Lionheart	RIG 2					I			
Lionheart	RIG 2						P		
Lionheart	RIG 2							I	
Lionheart	RIG 2								I
Taro	RIG 3		P						
Taro	RIG 3			I					
Taro	RIG 3				P				
Taro	RIG 3					I			
Taro	RIG 3						P		
Taro	RIG 3							I	
Taro	RIG 4			I					
Taro	RIG 4					P			
Taro	RIG 4							P	

¹Subject to receipt of all permits. Preliminary EIAs approved for two drill sites to date, requiring no full EIA, and other permits are progressing in line with expectations.

²Planned to be sourced externally

SITE INFRASTRUCTURE: INDUSTRY WATER CYCLE AND PIPING

Vulcan intends to use an intermediate heat exchanger at the nine Phase One well sites to capture the heat from the geothermal brine into a closed loop industrial water cycle which will pipe hot water to the Organic Ranking Cycle plants (ORCs). Once the heat has been used at the ORC, the cool water is sent back to the heat exchanger. The Li-rich brine is sent from the heat exchanger to the LEP and then back to the injectors.

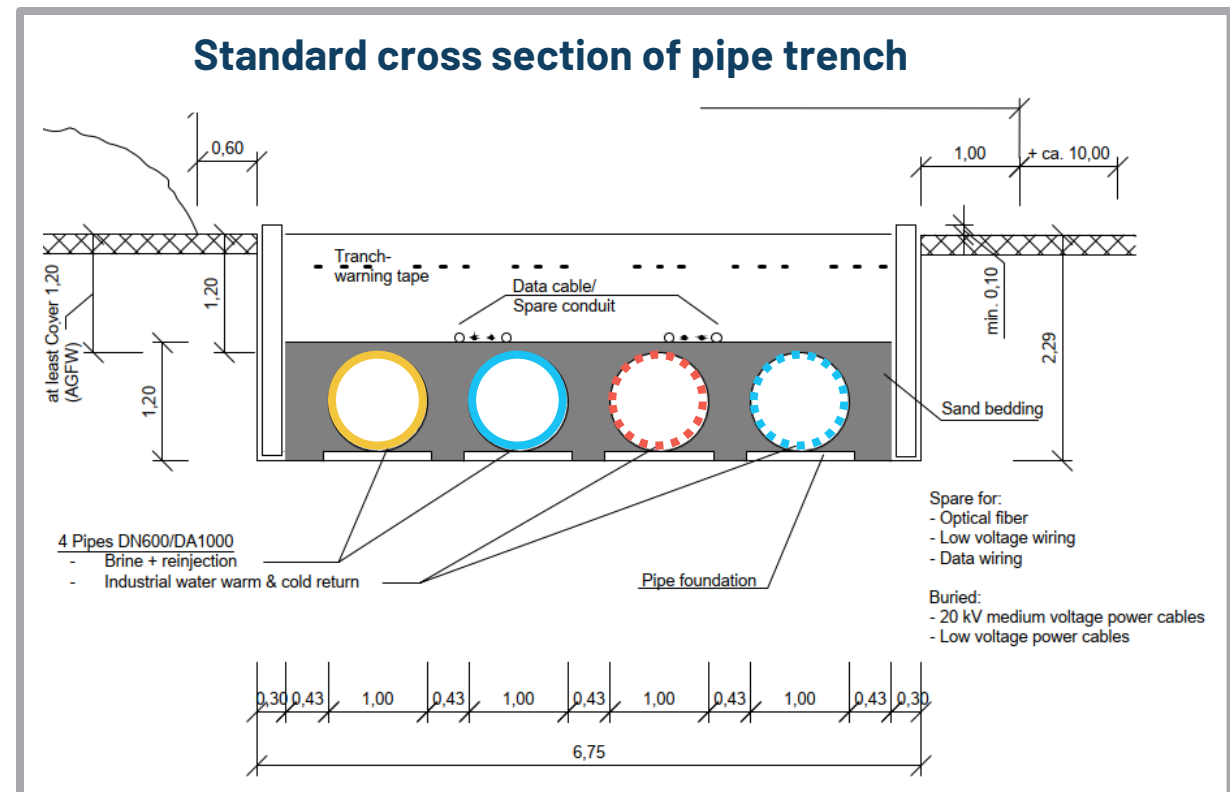
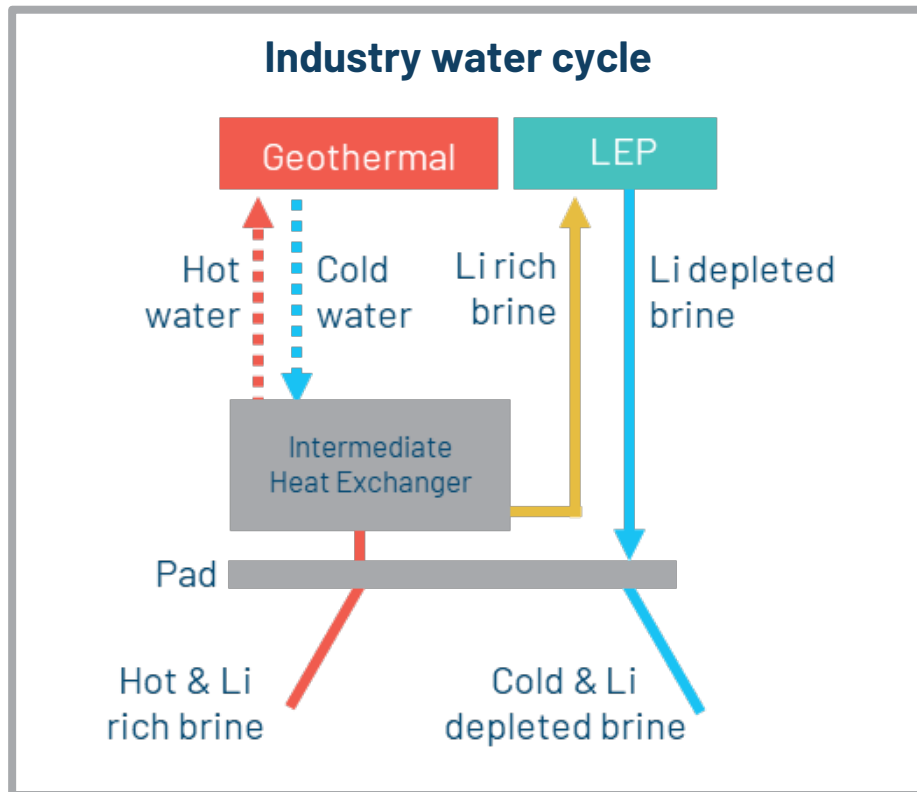

PROPOSED PIPELINE SYSTEM

Interconnecting Power and Piping network

Connecting multiple wells¹ with ORCs, LEPs and Well sites with:

- Hot/Cold water
- Li-rich/Depleted Li brine
- Power

Taro – 5km pipelines

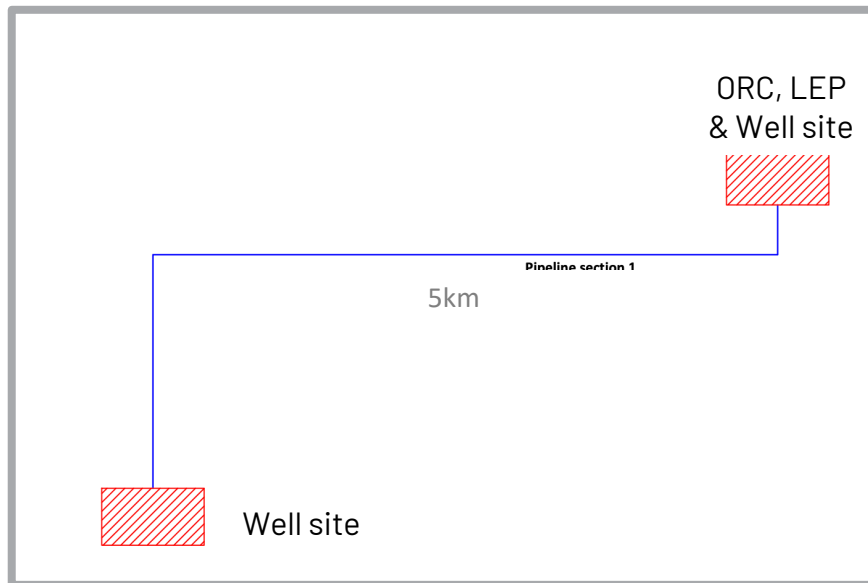

Lionheart – 16km total of pipelines

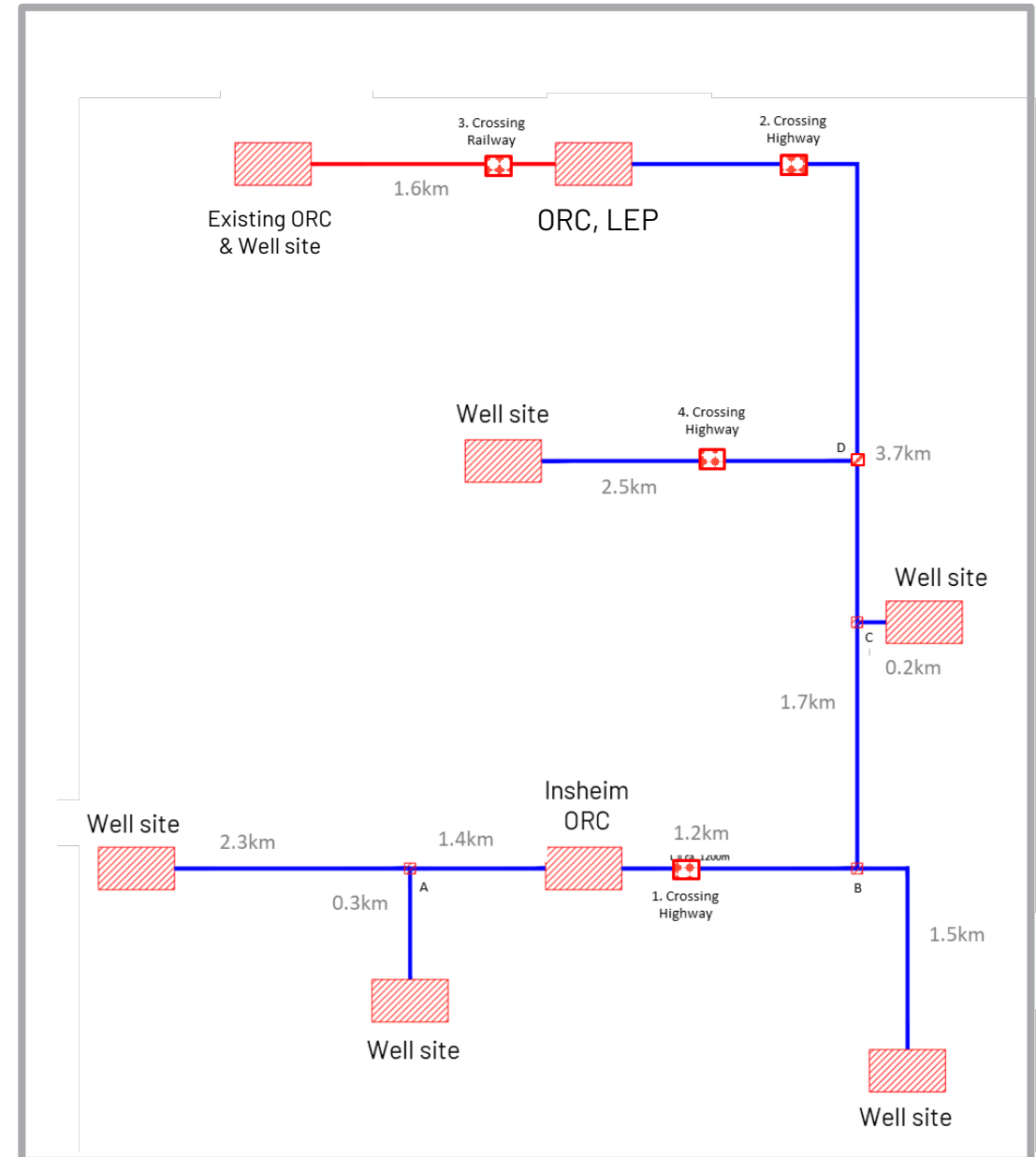

¹Subject to receipt of all permits.

GEOTHERMAL ENERGY PLANTS

Phase One: one existing geothermal plant and two new sites

	Insheim ORC (Existing)	Lionheart ORC ¹	Taro ORC ¹	Total ¹
Power Production (MW p/a)	4.2	24.5	8.4	37.1
Heat Production (MW p/a)	0.5	29.9	0.0	30.4
Power Production (MWh p/a)	34,856	203,326	69,712	307,893
Heat Production (MWh p/a)	4,150	248,140	-	252,290

Future ORC plant

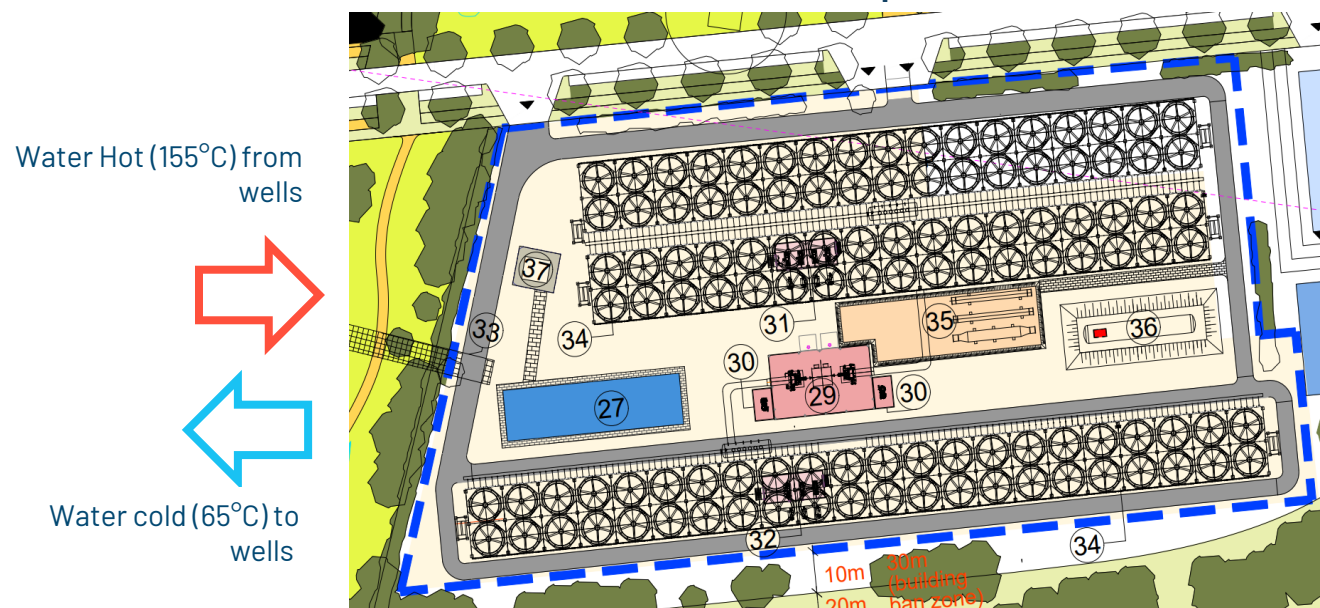

Vulcan's existing Insheim ORC plant



¹These are production targets, with planned production subject to successful development drilling. Please see disclaimer regarding forward looking statements on slide 2.

ENERGY BALANCE: NET POSITIVE PRODUCER OF RENEWABLE ENERGY¹

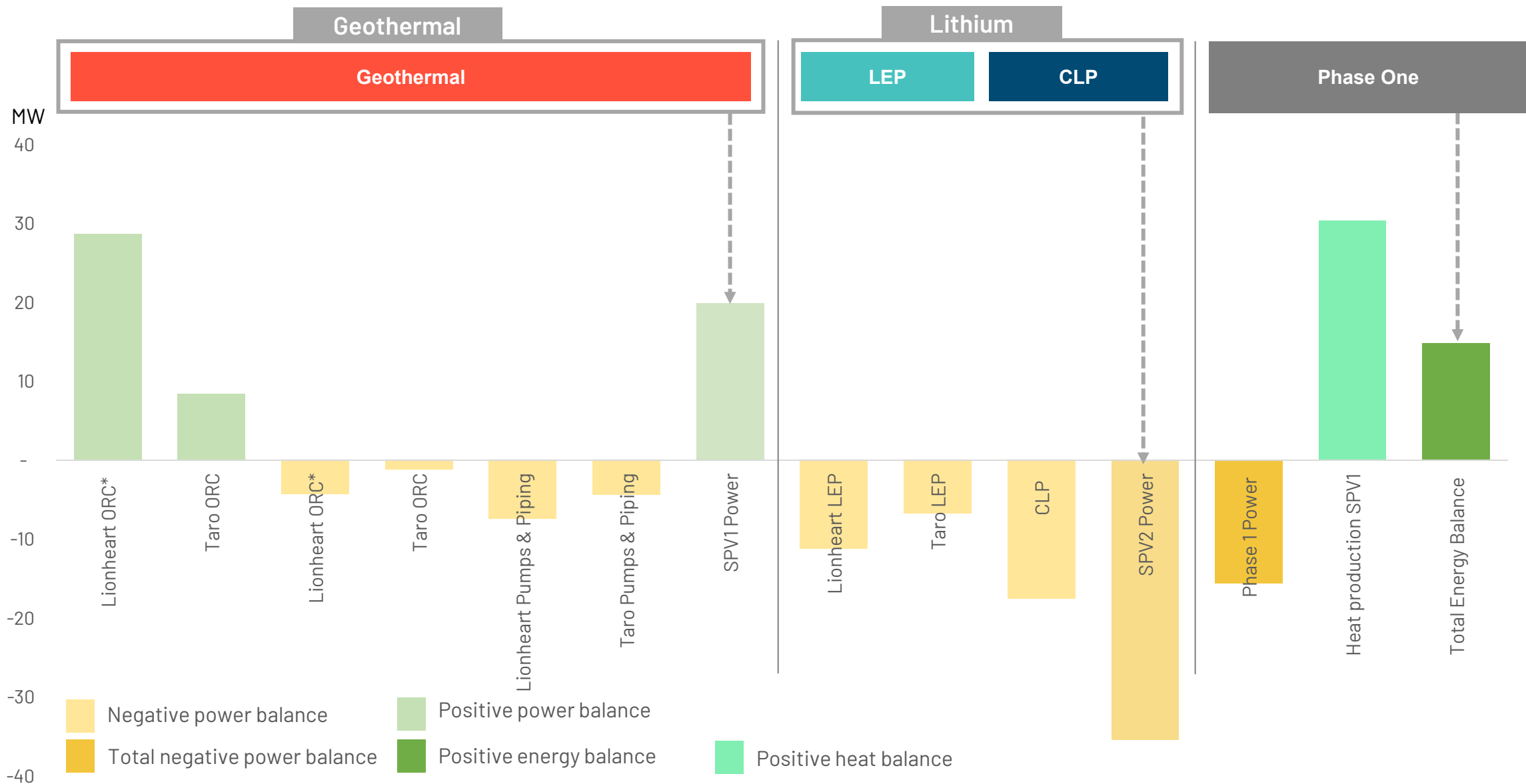

¹Vulcan's Phase One is a net consumer of power, and a net producer of heat. The overall positive energy balance is a net effect of these two different types of energy.

VULCAN IN-HOUSE PILOTING AND TESTWORK

- In-house designed and operated lithium extraction pilot plant operational since April 2021 (PP1 – low pressure).
- >13,000 of hours of continuous pilot plant test data from PP1, and latterly >1,000 hours of operation from high pressure P1A, to inform DFS.
- VULSORB™ lithium extraction sorbent developed in-house, shown to be best performing option.
- Test-work to continue to de-risk and inform engineering during bridging phase.
- In-house designed Demo Plant under construction, planned to start operation mid-year, training staff in pre-commercial environment prior to start of commercial production.

Pilot Plant Low Pressure (LP)



Pilot Plant High Pressure (HP)

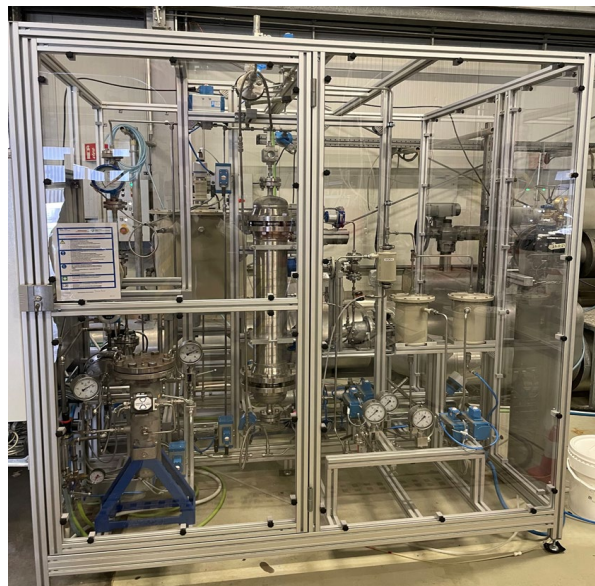

Demonstration Plant (LP & HP)



IMPROVED IN-HOUSE LITHIUM EXTRACTION FLOW SHEET

Improvement #1: VULSORB™

- Vertically integrated production
- 10% less OPEX¹
- €24M less CAPEX¹

Improvement #2: VULSORB™ + High Pressure (HP) operation

- No degassing, no CO₂ compression
- No pre-treatment or post-treatment
- Removes lime and HCl consumption
- No undissolved silica waste stream
- Reduced risk of scaling/corrosion

▪ **Lower OPEX¹**(-31%/t LHM)

▪ **Lower CAPEX¹**(-€124M)

▪ **Lower environmental impact:**

- Lower energy consumption
- Lower reagents consumption

Upgrading to a High Pressure system with VULSORB™

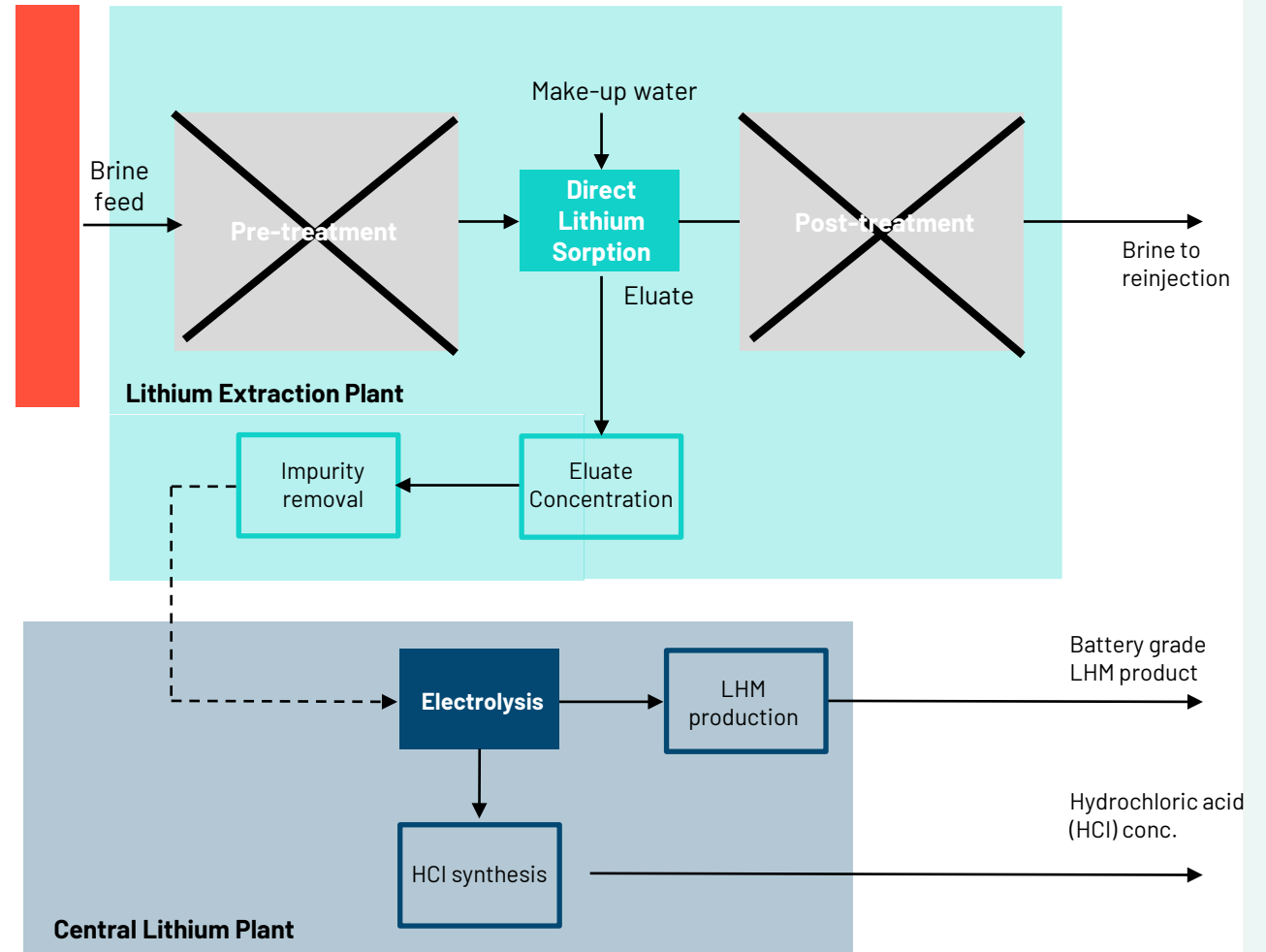

¹Compared to DFS figures without VULSORB™ and with low pressure system. Testing with high pressure system more limited than low pressure. Vulcan has adopted the high pressure system in its planned development, and will continue to run testwork to further de-risk the system during the bridging phase.

LITHIUM EXTRACTION PLANTS (LEPs)

Phase One

Two sorption-type LEPs:

- **LEP Taro:** “standard” modular sized of 8,000tpa LHM equivalent fed by 300l/s Li-rich brine. Asset to be built next to Taro’s ORC plant.
- **LEP Lionheart:** “Double-size” 16,000tpa LHM equivalent fed by 600l/s Li-rich brine. Asset to be built next to Lionheart ORC.
- From both LEPs, trucking of **Lithium Chloride Solution** to the CLP for transformation to LHM.
- Modular build allows for further development across other phases in URVBF.

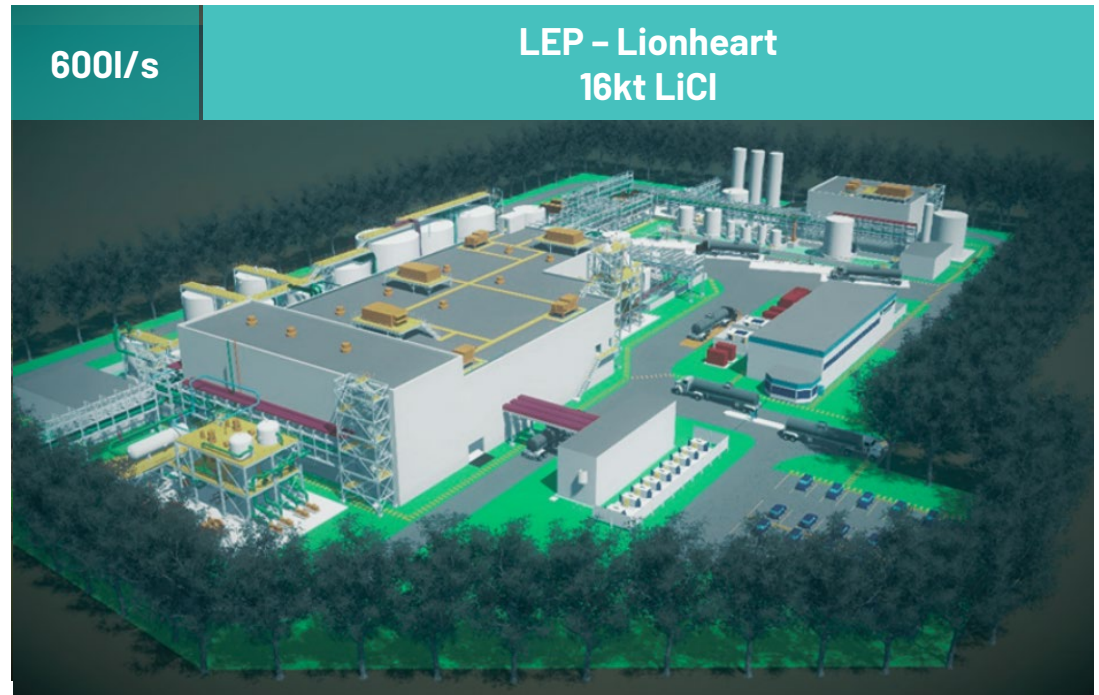

LITHIUM CHLORIDE CONVERSION TO LHM: CLP

Phase One

- Conversion of lithium chloride to **battery grade LHM** using **electrolysis**.
- Process uses similar technology as used in the chlor-alkali industry, which has been **used for over a century**. **Significant** in-house expertise at Vulcan.
- CLP planned to be located in Frankfurt (Höchst Industrial Park). Close to **100,000sqm secured**, enough for **significant expansion**.
- Höchst is **one of Europe's largest industrial estates** and is home to around 90 chemical and pharmaceutical companies.
- **24,000tpa LHM capacity** with space for at least a further phase of equal size.
- **By-products** HCl 67kpa and Sodium Hypochlorite 3kpa.

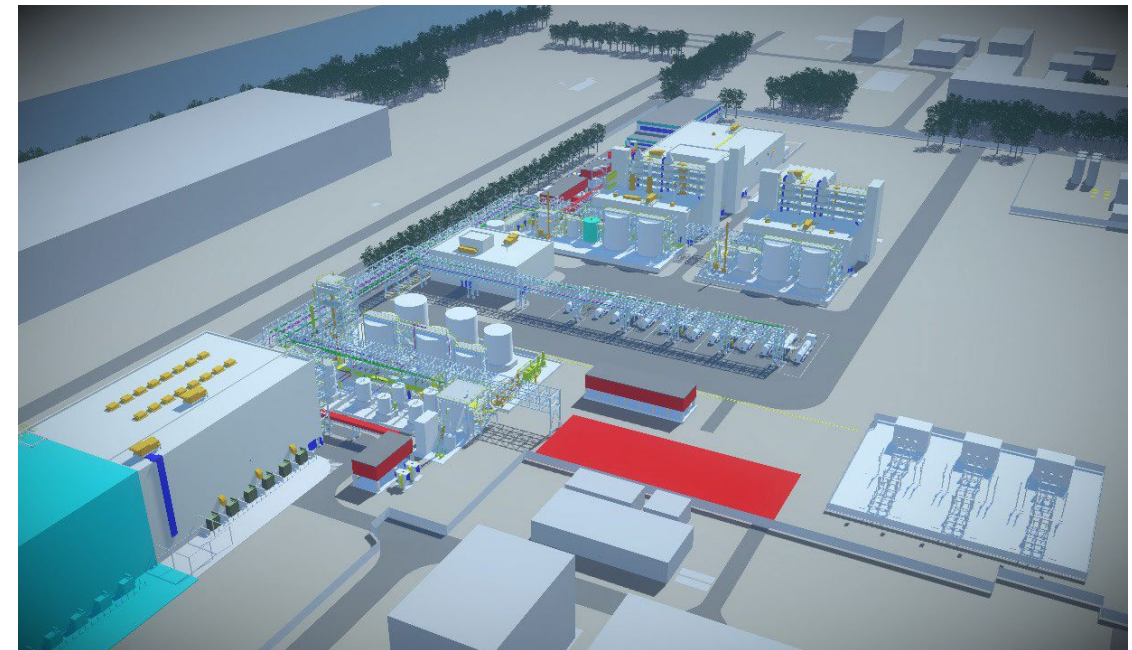

LiCl from LEPs

CLP - Frankfurt
24,000tpa LHM

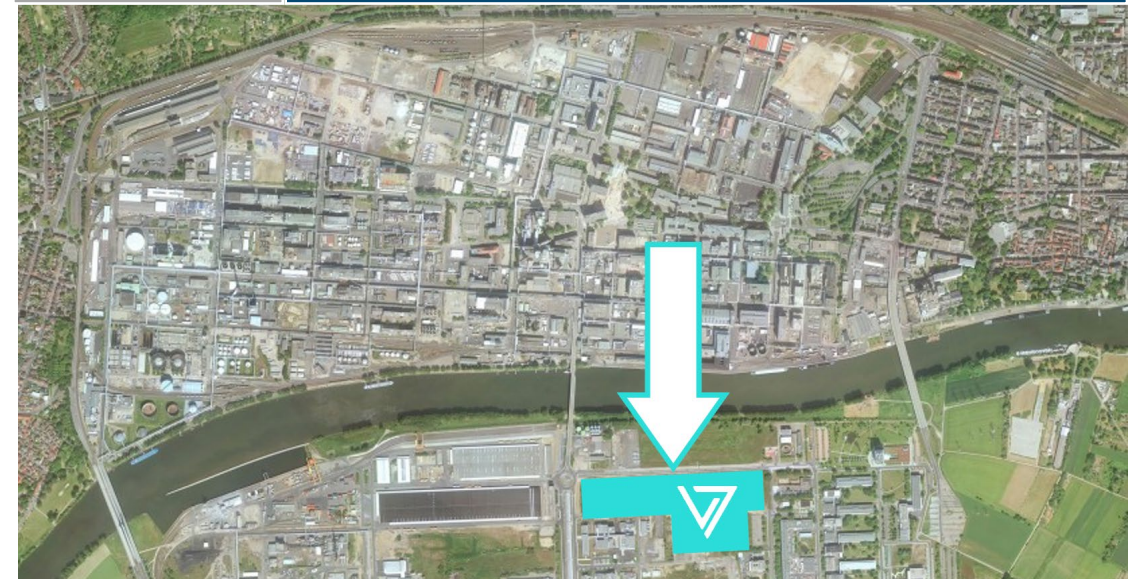

CAPEX ESTIMATED BREAKDOWN¹

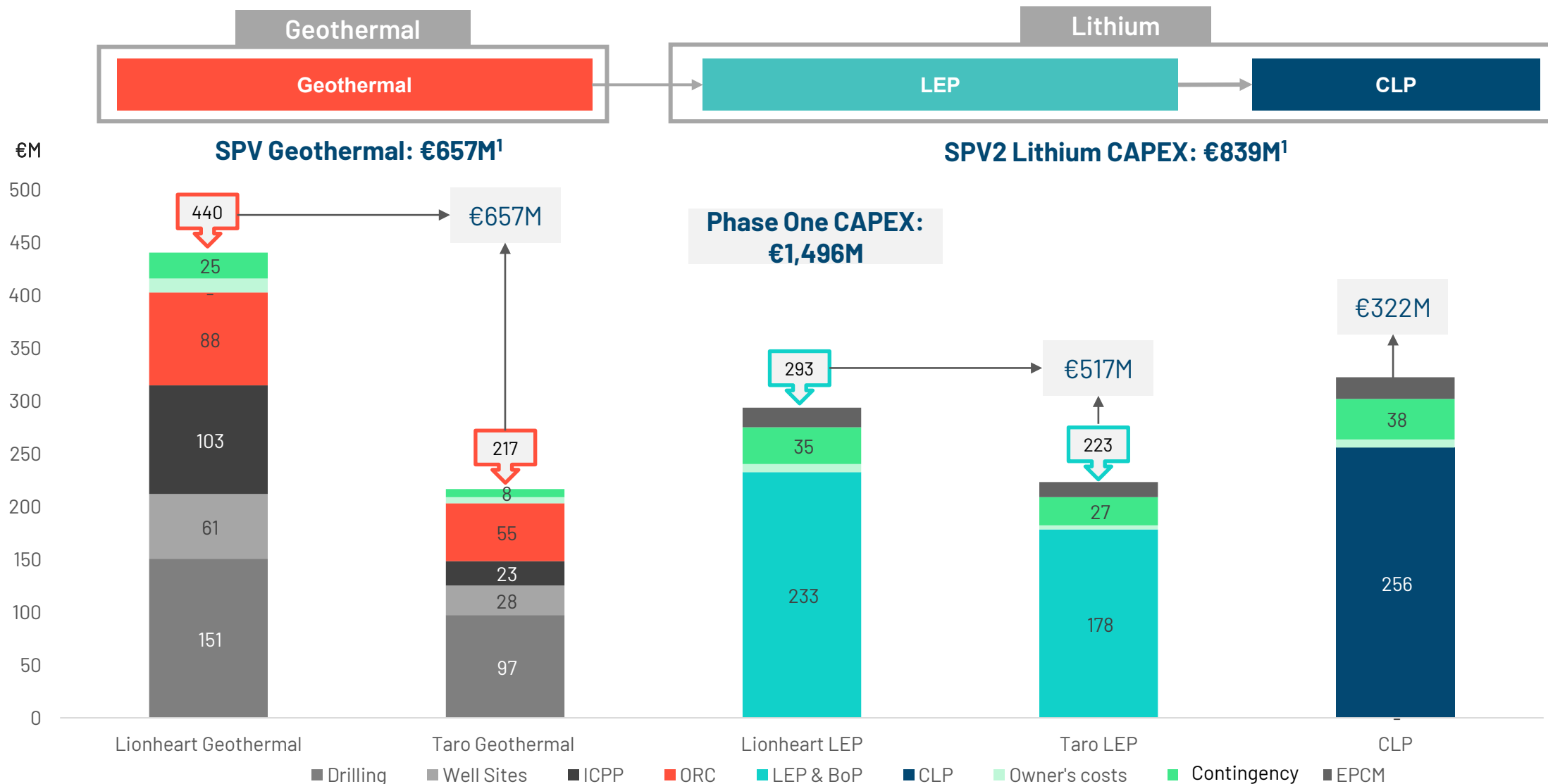

¹Estimate Accuracy Based on Design Maturity: SPV Geothermal Est at +/- 20%, SPV Lithium Est at +20/-15%. SPV Lithium planned to have the original DFS estimate at Class 3 accuracy (+/-15%), however several value improvements opportunities were identified late in the DFS and sufficient engineering was not able to be completed to achieve Class 3, therefore these opportunities have a lower accuracy than the original estimate, therefore giving an approximate DFS Phase accuracy of (+20/-15%). These opportunities are planned to be developed to the same detail and accuracy as the original estimate in the next phase.

OPEX ESTIMATED BREAKDOWN - 20Y AVERAGE

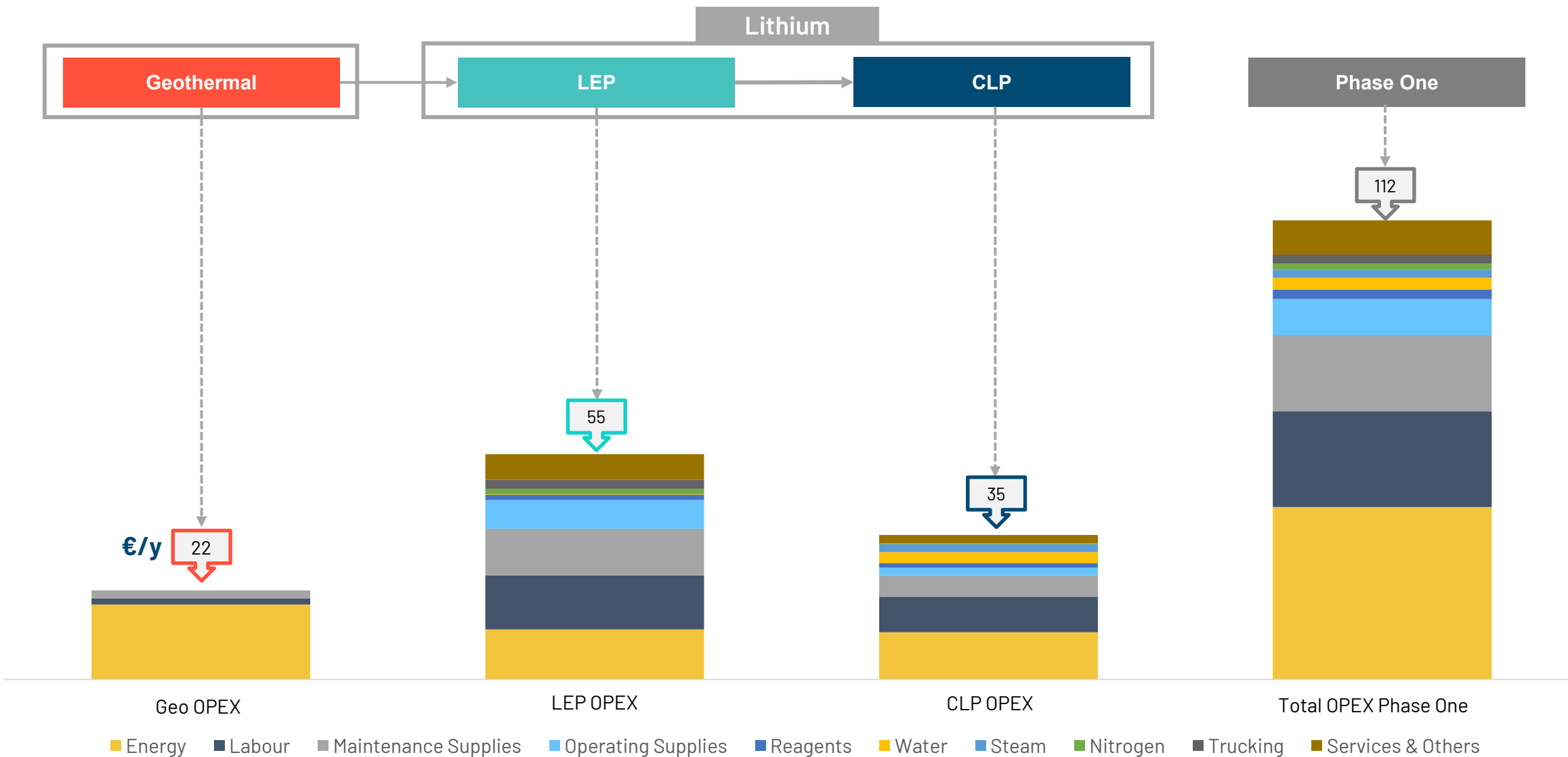



GLOBAL COST CURVE LHM – PROJECTED 2025

Vulcan’s Zero Carbon Lithium™ Project has the potential to be one of **the lowest cost integrated LHM projects** in the world.

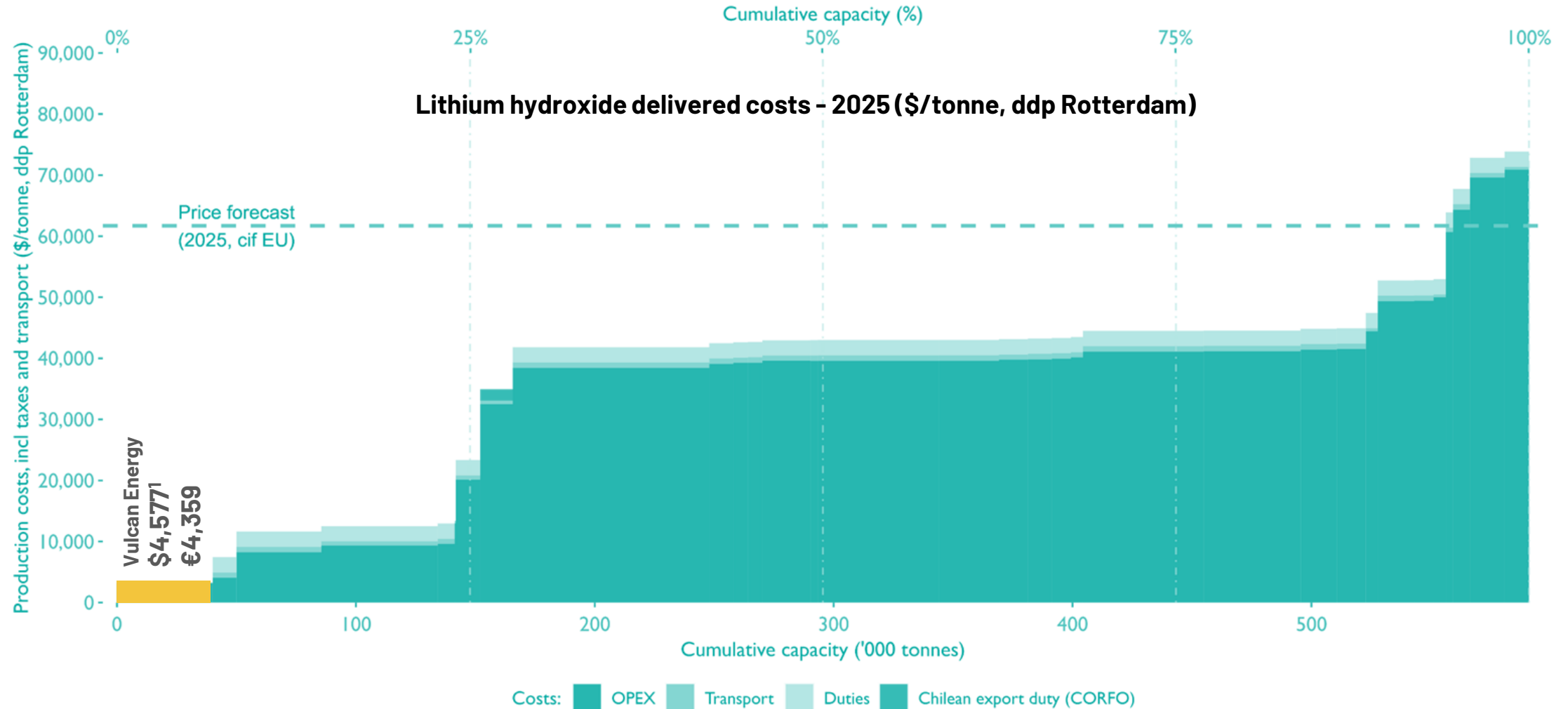

¹Projected cost curve provided by Fastmarkets and Vulcan’s OPEX estimate provided by the Company. Vulcan’s OPEX converted from € to \$ using 1.05 EUR/USD FX. Vulcan has used a projected cost curve by Fastmarkets as it is the Price Reporting Agency (PRA) for lithium for the London Metals Exchange, and as in Vulcan’s view it would be invalid to compare Vulcan’s future projected costs with current costs from other companies. Fastmarkets’ estimate of a project’s costs uses a bottom-up approach based on assumptions about the operations. On top of this, costs for transport to a common location and any duties that would be applied are added to allow comparison from different sources.

STRATEGIC SUPPORT WITH LONG TERM LITHIUM SUPPLY CONTRACTS

Five key offtake agreements secured, binding, take-or-pay, with mixture of pricing mechanisms to provide stability but keep some exposure to upside in pricing



✓ **Binding lithium hydroxide offtake agreement, 10-year term.**

A\$76M (€50M) equity investment from Stellantis. This represents the **world's first upstream investment in a listed lithium company by a top tier automaker.** Stellantis is now Vulcan's second largest shareholder with ~8% shareholding.



✓ **Binding lithium hydroxide offtake agreement, initial 5-year term.**



✓ **Binding lithium hydroxide offtake agreement, initial 6-year term.**



✓ **Binding lithium hydroxide offtake agreement, initial 5-year term.**



✓ **Binding lithium hydroxide offtake agreement, initial 5-year term.**

LHM PRICE FORECAST

Lithium hydroxide price forecasts¹- €/t

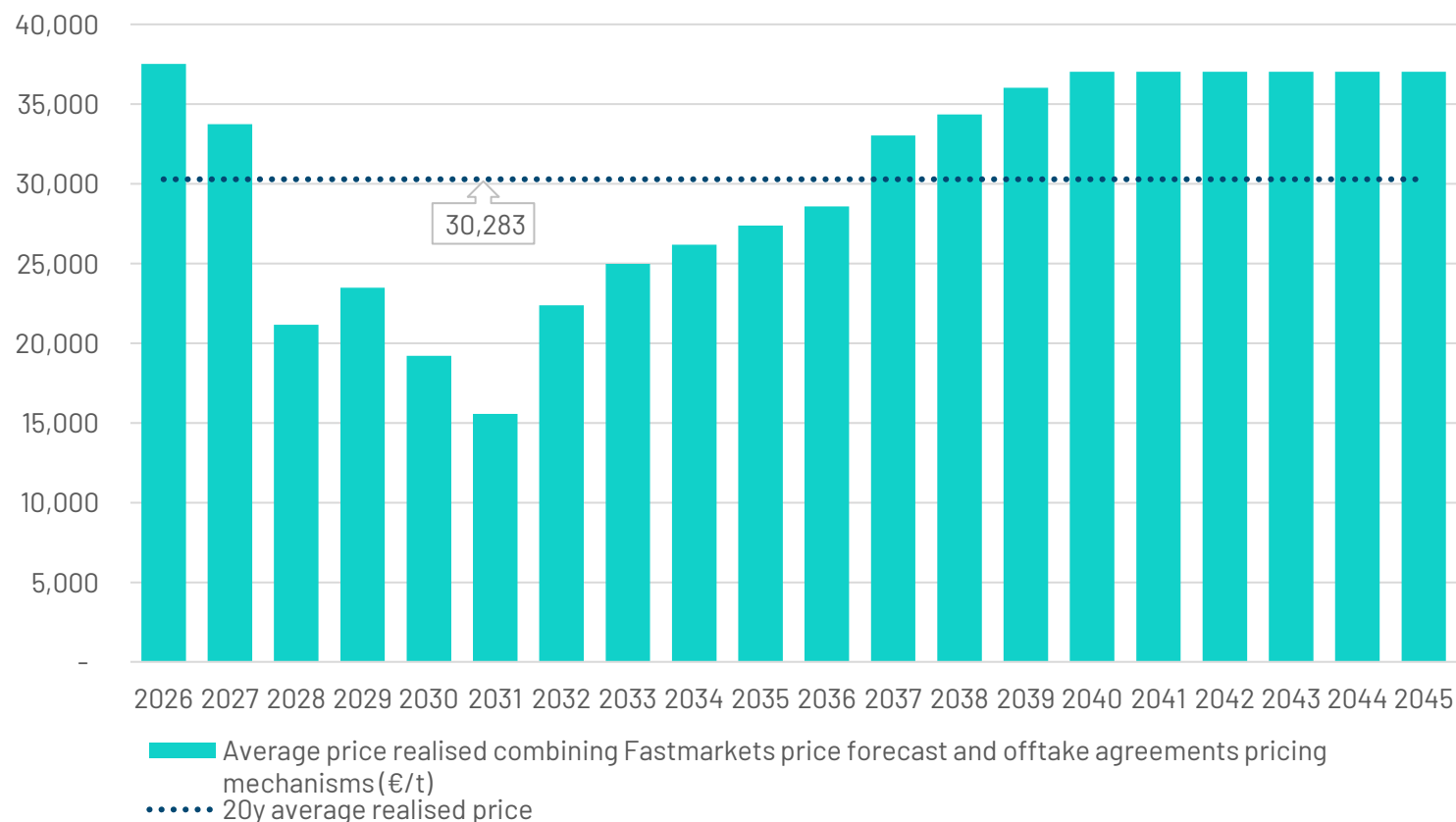

LHM prices as of Feb. 2023 are reported at \$79,000/t (Fastmarkets)

	Forecast average price realised combining Fastmarkets price forecast and Vulcan offtake agreements pricing mechanisms (€/t)
<i>Average</i>	30,283
2026	37,524
2027	33,743
2028	21,153
2029	23,477
2030	19,209
2031	15,571
2032	22,385
2033	24,975
2034	26,177
2035	27,378
2036	28,580
2037	33,020
2038	34,353
2039	36,018
2040	37,017
<i>Long term price</i>	<i>37,017</i>

¹The average forecast realised price per tonne of LHM is taking into consideration Fastmarkets long term price forecast (min 57.5% LiOH)(\$/kg, EU & US) and combining it with Vulcan's pricing concluded in offtake agreements which includes price floors and ceilings, fix prices, and price indexed on indexes like Fastmarkets. Therefore, the average realised price forecast varies from the Fastmarkets long term price forecast. The average realised price forecast is taken into consideration in our financial model and is used to underpin forecast revenues. Lithium prices are subject to unpredictable fluctuations, driven in part by changes in the balance of global supply and demand as well as international, economic and geopolitical trends and developments. Any decrease or significant volatility in the price of or demand for lithium could have a detrimental effect on Vulcan Group's business.

TARGET REVENUES – 20Y AVERAGE

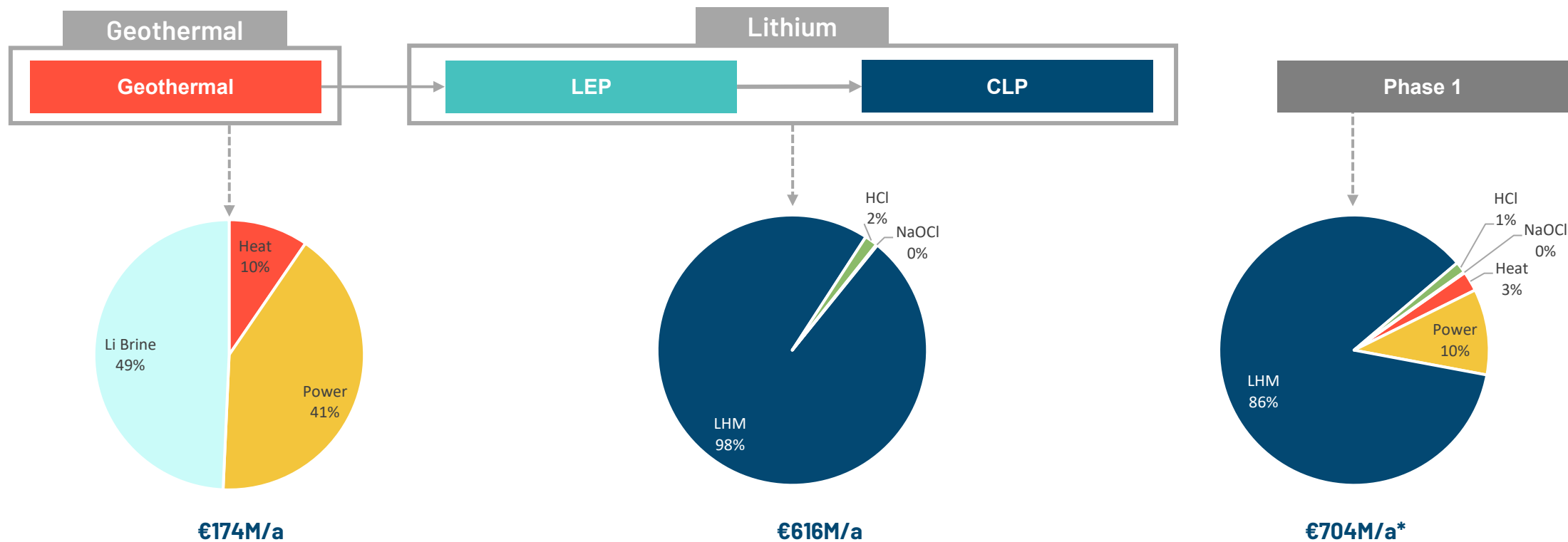

Annual Revenue €M/y, 20y average (excluding 2026 ramp-up)

	SPV Geothermal			SPV Lithium			Total Phase 1
	Heat	Power	Li Brine	LHM	HCl	NaOCl	
Revenues Geo	16.7	71.8	86.0				174.5 ²
Revenues Li				605.8	9.4	0.8	615.9 ²
Revenues Phase One¹	16.7	71.8	86.0	605.8	9.4	0.8	704.4 ²

¹LiCl is excluded as it is an internal sale if SPV1 and SPV2 are within the same entity

² Project life is modelled for 30 years, average revenues displayed are based on 20 year forecast average to be more accurate, given power feed-in tariff should be in place during this period, and due to the difficulty in predicting longer term power prices.

TARGET PROJECT ECONOMICS SUMMARY¹

COMPELLING ECONOMICS: DFS vs PFS^{2,3}

- **>250% increase** for Phase 1 NPV₈: **€3.9Bn** NPV₈ pre-tax, **€2.6Bn** NPV₈ post-tax.
- **>40% increase** in rate of return : **34% IRR** pre-tax, **26% IRR** post-tax.
- **>200% revenue increase** for Phase One: **>€700Mpa**, EBITDA margin of **84%**.
- **€4,359/t LHM OPEX** – potential to be one of the lowest cost operations⁵.
- **Reduced 3.5-year** payback (integrated project).

	Geothermal	Lithium	Phase 1
Revenues €M/a ⁴	174	616	704
Net Op. Cash Flow €M/a*	111	328	437
NPV pre-tax m€	724	3,192	3,917
NPV post-tax m€	435	2,149	2,584
IRR before Tax	11.4%	45.9%	34.4%
IRR after Tax	7.3%	34.0%	26.1%
Payback in years	6.5	2.5	3.5
Total CAPEX m€	657	839	1,496
<i>Geothermal</i>	657		657
<i>LEP</i>		517	517
<i>CLP</i>		322	322
Avg OPEX €/t LiOH		4,359	4,359

Notes: Lithium Hydroxide Battery Quality at €30,283/t

¹These are targets and may not be achieved. Please refer to the Forward-Looking Statement disclaimer on slide 2.

²Please see Economic Analysis section for more detailed assumptions, breakdown and analysis. Figures are comparative to Integrated PFS published in January 2021. For financial definitions please see Appendix 14.

³See Vulcan Integrated PFS announcement, Jan 2021. Values from PFS are lower confidence than the DFS and should be treated with caution until they are updated with more recent data.

⁴LiCl is excluded in integrated Phase One model, as it is an internal sale if SPV1 and SPV2 are within the same entity, therefore total revenue is not the same as with separate SPV model. Economics are targets based on estimations in DFS.

⁵Based on Fastmarkets 2025 onwads projections of lithium market, see economic analysis section.

PERMITTING PROCESS – CURRENT UPDATE¹

Rhineland-Palatinate	Mining authority	Licenses	Exploration license 
			Production license 
		Drilling	Pre-EIA 
			Main operation plan (one well site, all wells)
			Special operating plan: Well pad
			Special operating plan: Drilling
			Secure land
	Drilling start		
	Pipeline	Pre-EIA	
		Secure land	
		Special Operating Plan: Pipeline	
		Pipeline construction	
	Regional authority	ORC	Pre-EIA
			Land acquisition
Building permit			
ORC construction			
Mining authority	LEP Demo	Operation plan 	
	LEP	Pre-EIA	
		Land acquisition	
		Building permit	
		Special Operating Plan	
LEP construction			
Hessen	Regional authority	CLP	Bimsch
			Building permit
			CLP construction

-  Permitting progress
-  Multiple exploration licenses granted
-  Insheim geothermal production license acquired
-  Multiple pre-EIAs granted in Taro sector, negates need for full EIA for Phase One in this sector
-  LEP Demonstration Plant operation plan approved

¹Vulcan notes that the permitting process for a geothermal project in Germany is continuous throughout integrated development, right up until the final permission to operate after the plants are built. Vulcan has initial approvals in place, and the permitting is progressing with finalisation expected within the planned development timeline. There is no guarantee that Vulcan will receive all of its permits within the planned time period or at all.
EIA = Environmental Impact Assessment

OUR UNIQUE SELLING POINT: LEADING ENVIRONMENTAL CREDENTIALS



Low ESG Risk Rating from Sustainalytics (01/2023)
First amongst peers and in the 2nd quartile Chemicals Industry



9,5kT CO₂ avoided from renewable energy generated at NatürLich Insheim in 2022.



ESG linked KPIs including individual and shared targets



Partnership with Karlsruhe Zoo Foundation supporting local biodiversity projects



Voluntary TCFD reporting company since 2021



Certified Carbon Neutral International Organisation from 2021¹



4 InfoCentres opened in Insheim, Landau, Karlsruhe, Mannheim and 1 mobile Infocentre for local community engagement



TNFD Forum Member assisting with framework development. Funds allocated for a biodiversity project



UNGC Member (Since February 2022)

¹Vulcan Group is certified as a carbon neutral organisation for 2021 under the Climate Active and South Pole certifications

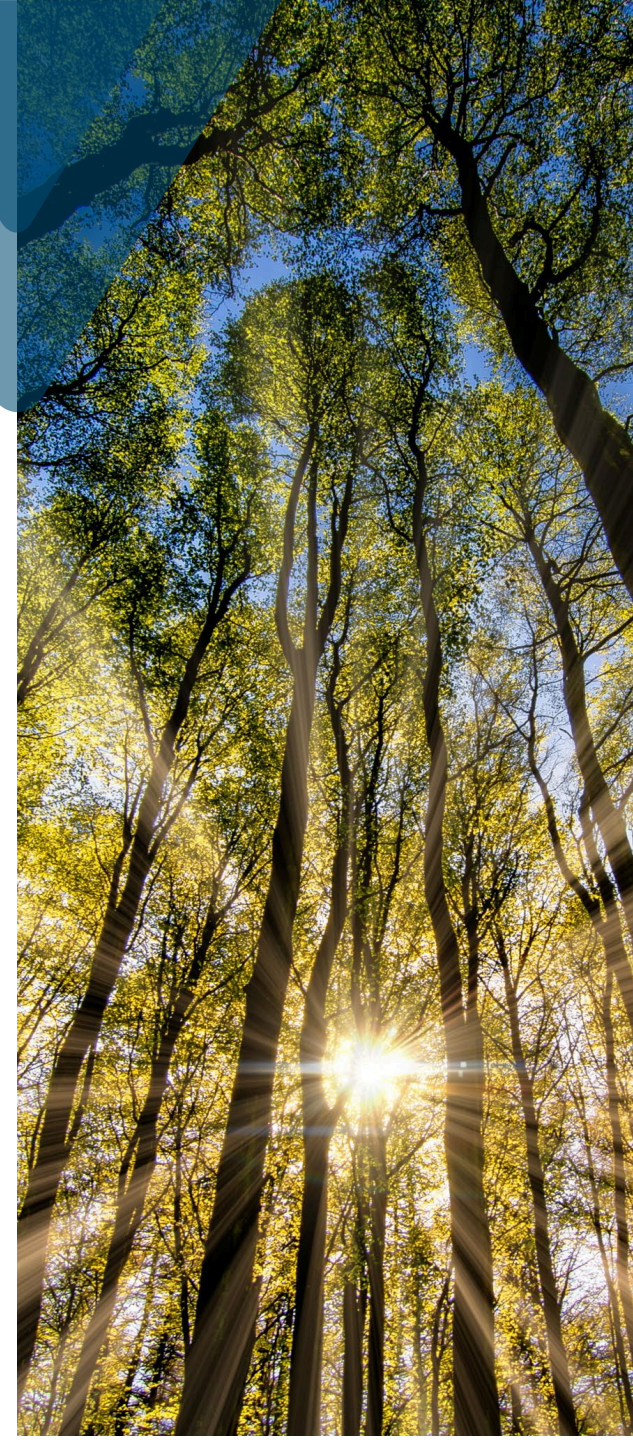



AIMING FOR LOWEST CO₂ FOOTPRINT IN THE LITHIUM INDUSTRY

Vulcan is developing the first and only net zero carbon, zero fossil fuels lithium project in the world¹.

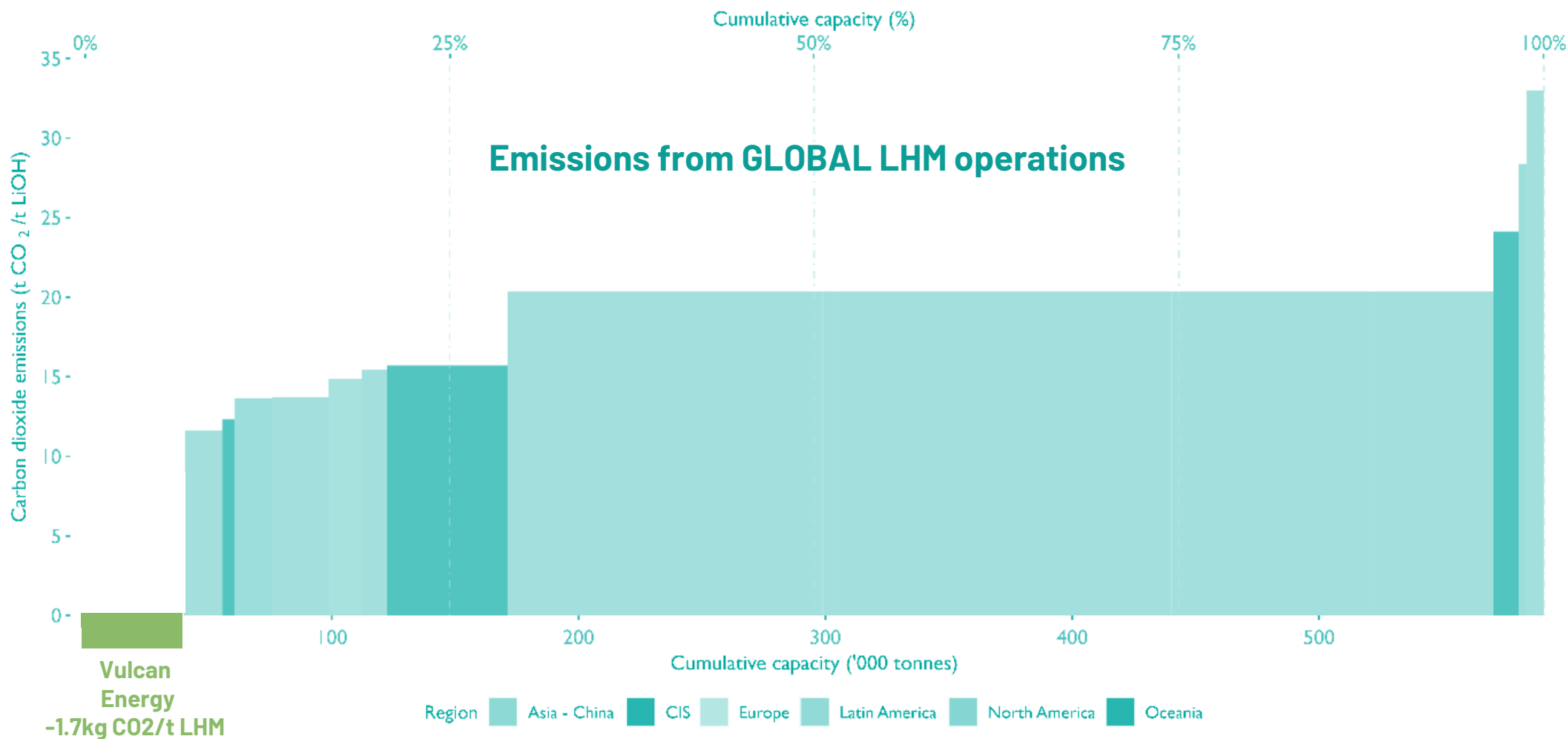

¹Sources: Fastmarkets projection for industry. Vulcan CO₂ value provided by Minviro. The CO₂ assessment is a cradle-to-gate study. It starts with the cradle: extraction of geothermal brine. Thermal energy of the brine is extracted and used for electricity and steam generation. Generated electricity is assumed to be exported to the German electrical grid. Part of the heat is exported for district heating, substituting natural gas use, and the rest of the heat is used for internal processes. It is assumed that of the electricity used throughout all processes 50% is sourced from the German grid and 50% is procured from additional wind generated electricity, on top of wind-based electricity that is already present in the German grid mix. Electricity, steam, hydrochloric acid (30% concentration) and sodium hypochlorite (15.8% concentration) are co-products of the lithium hydroxide monohydrate product. All co-products are accounted for using system expansion, meaning no allocation is required. The climate change impact for the lithium hydroxide monohydrate product for the assumptions described above is -1.7 kg CO₂ eq. per kg LiOH·H₂O. Vulcan is not aware of any other net zero carbon, zero fossil fuels lithium projects either in operation or development.

OVERALL LEP AND CLP WATER BALANCE

Vulcan's Zero Carbon Lithium™ Project has been engineered to have an extremely small water footprint¹

Location	Tonnes Water/LHM
Taro LEP	
Net freshwater input	0.58
Lionheart	
Net freshwater input	1.16
CLP	
Net freshwater input	0.08
Net High Purity water input	1.89
Total Water Consumption	3.71
Water in HCl	1.92
Water in LHM	0.43
Water in Products	2.35
Water Consumption Net of Products	1.36

¹Vulcan figures internal and calculated together with Hatch study as part of DFS, then incorporated into Minviro LCA study 2023, industry peer comparison study from Vulcan research of public company data, and as per the Minviro LCA study, 2021.

2023 – OUR SHORT TERM OBJECTIVES

DFS 1	Phase One DFS (complete)
Demo	Demo Plants to commence operation and first LHM production from demo
Drilling	Start drilling of new production/re-injection wells in Phase One area
Permits	Grant of relevant permits in line with development timeline for 2023
Funding	Secure funding: equity for Phase One, pursue public funding, substantially advance debt funding process
Execution	Build and deliver project execution model: organisation in place and award of key packages & contracts for Phase One
Phase+	Complete Phase Two definitive feasibility study



TARGET PROJECT TIMELINE - PHASE ONE

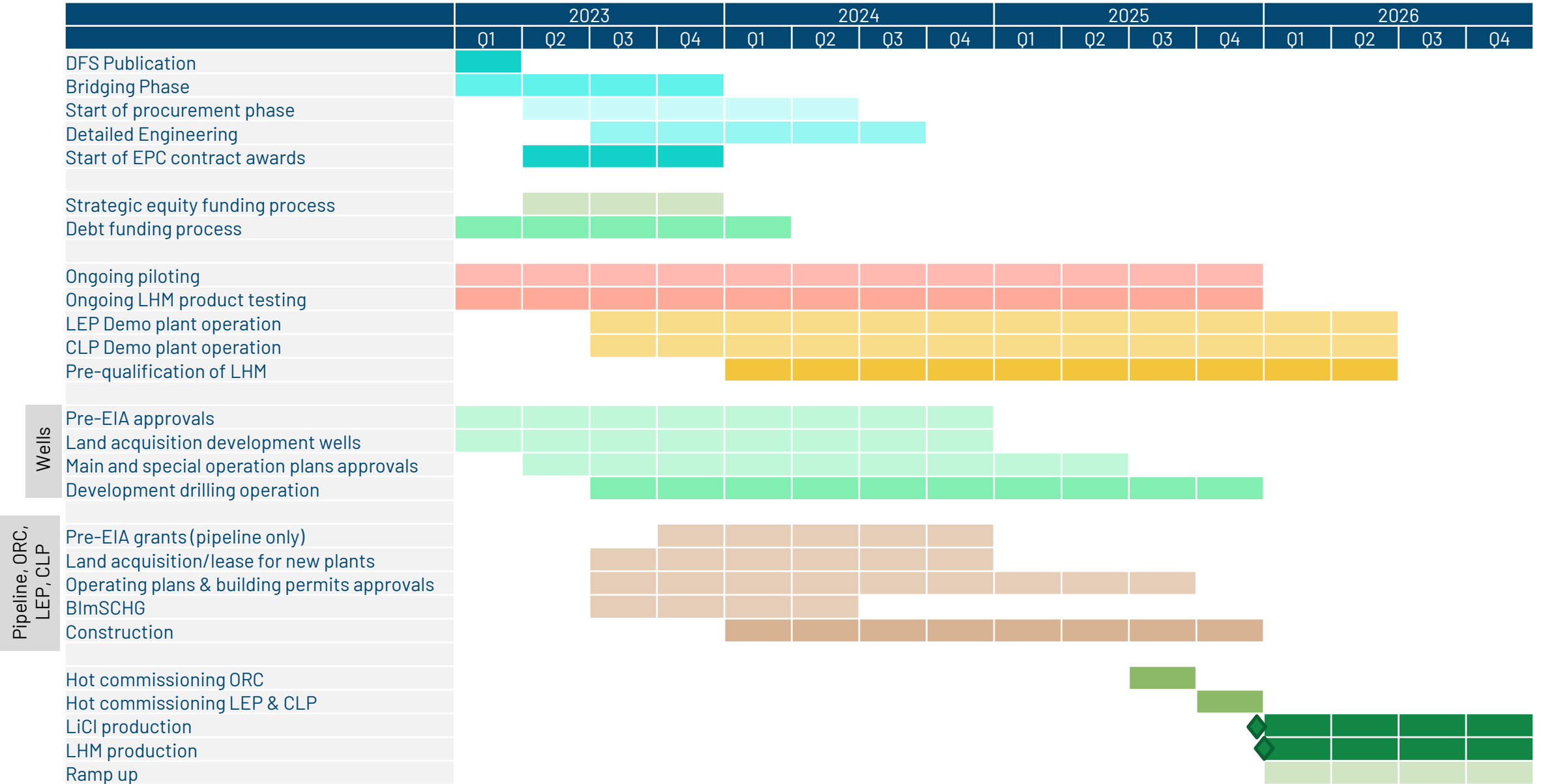

MATRIX ORGANISATION GEARED FOR EXECUTION AND DELIVERY

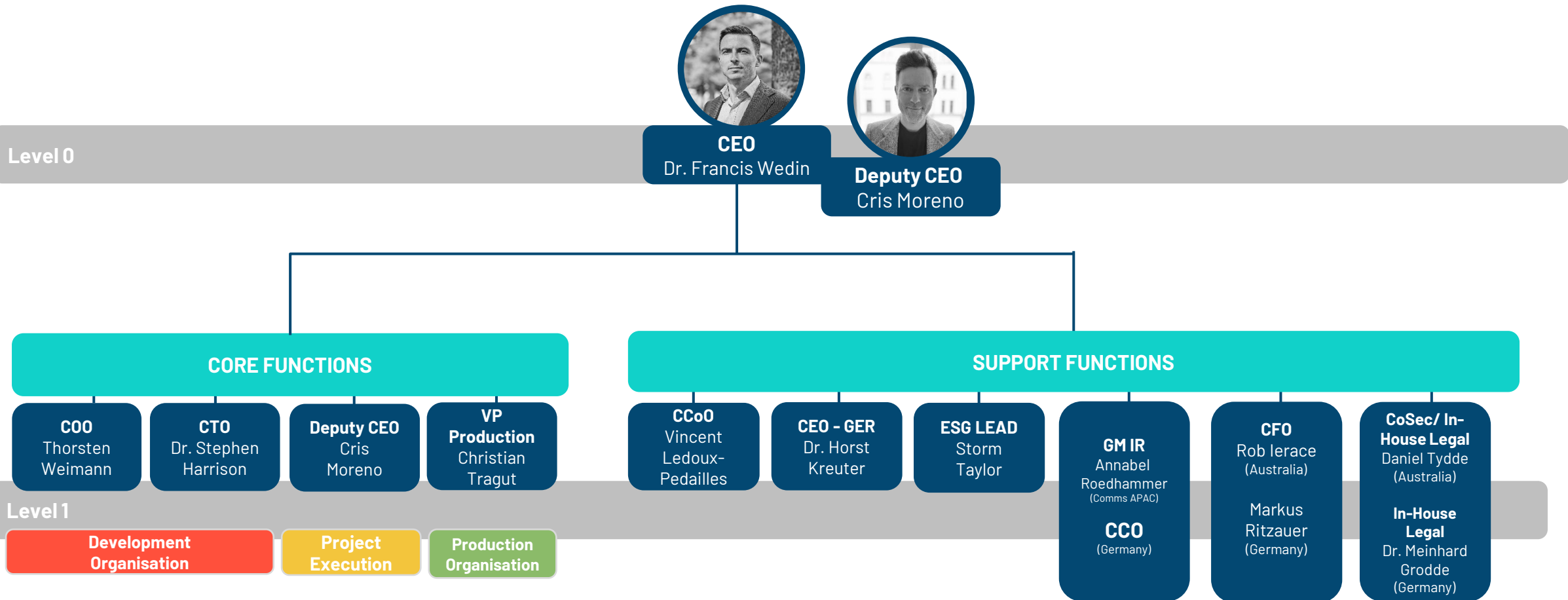

ROBUST TARGET PROJECT FINANCIALS AND STRATEGIC PROJECT¹

FUNDING TARGETED FROM A MIX OF EQUITY, DEBT AND GRANTS

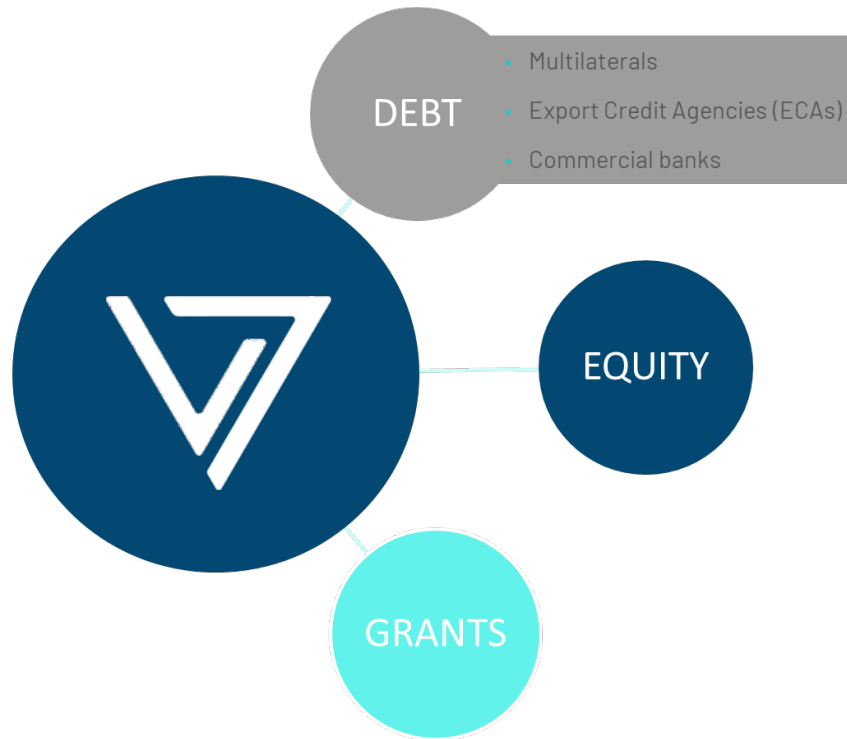

MULTIPLE TARGET OPTIONS FOR VULCAN

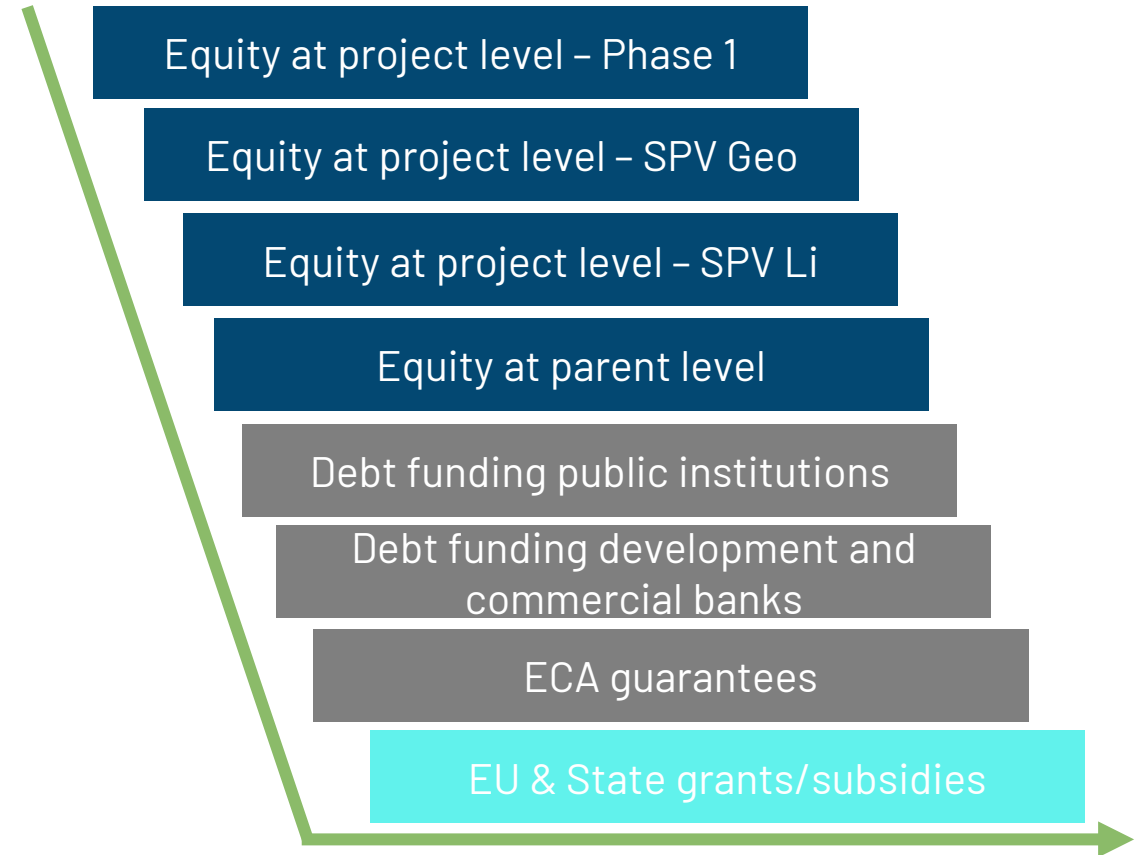

BNP PARIBAS appointed as Financial Advisor toward financing the Zero Carbon Lithium™ Project. Financing process commenced¹.

¹There are no guarantees that Vulcan will be able to raise the funding required for the further implementation of its Zero Carbon Lithium™ Project. For further information please see the risk factors in Appendices 6 and 7

CONCLUSIONS

- The **first integrated renewable energy, lithium extraction and lithium hydroxide refining project** development, seeking to supply the battery electric vehicle industry from Europe, for Europe.
- **World-leading sustainability credentials:** engineered specifically to be world-first zero Scope 1 fossil fuels, net zero GHG emissions from Scope 1, 2 and 3, low water consumption project.
- **Highly attractive financial model** from DFS.
- Company moving Phase One Project into **bridging engineering** phase, assisted by Hatch Ltd.
- Focus going forward on **transitioning to project execution** and operations company.
- Demonstration Plant to assist with **training operations team**.
- Team focused on **further de-risking** during project development, particularly during permitting process.
- Targeted **start of production end-2025**.
- **Financing process for Phase One commencing**, working with BNP Paribas as debt advisor. Equity financing at a project level, as well as parent level, being viewed as an option.



APPENDICES

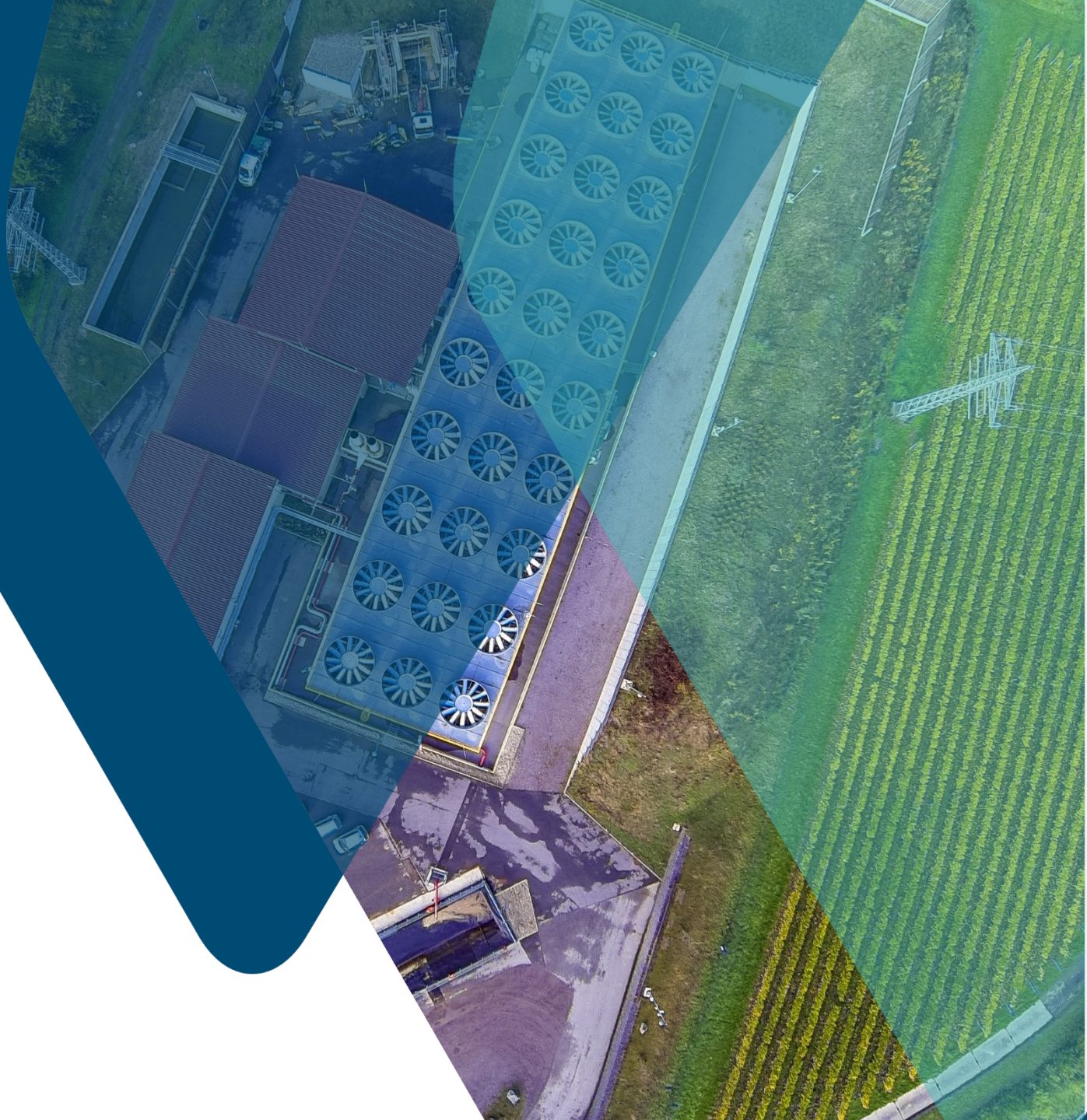

APPENDIX 1: BOARD OF DIRECTORS



Dr. Francis Wedin
Managing Director & CEO

Founder of Vulcan Zero Carbon Lithium™ Project. Lithium industry executive since 2014. Previously Executive Director of ASX-listed Exore Resources Ltd. Track record of success in lithium industry as an executive since 2014, including the discovery of three resources on two continents. PhD in Geology, MBA in Renewable Energy, global experience in battery metals sector.



Gavin Rezos
Chair

Executive Chair/CEO positions of three companies that grew from start-ups to the ASX 300. Extensive international investment banking experience. Investment banking Director of HSBC with senior multi-regional roles in investment banking, legal and compliance functions. Currently Chair of Resource and Energy Group, principal of Viaticus Capital, Non-Executive Director of Kuniko Limited and Non-Executive Chair Resources & Energy Group Limited.



Ranya Alkadamani
Non-Executive Director

Founder of Impact Group International. A communications strategist, focused on amplifying the work of companies that have a positive social or environmental impact. Experience in working across media markets and for high profile people, including one of Australia's leading philanthropists, Andrew Forrest and Australia's former Foreign Minister and former Prime Minister, Kevin Rudd.



Annie Liu
Non-Executive Director

Annie is the Executive Director of Purchasing for the Ford Model e Line, for all electric products and technology. Annie started her 20+ year career as an engineer at Microsoft before moving to Tesla where she progressed to Head of Supply Chain, Battery and Energy at Tesla. Annie is experienced in building and leading teams from product incubation stage to scale up and mature market bringing a unique blend of entrepreneurial initiative and ability to meet organisation and market growth needs.



Dr. Heidi Grön
Non-Executive Director

Dr. Grön is a chemical engineer by background and an accomplished business leader with over 22 years' experience in the chemicals industry. Since 2007, Dr. Grön has been a senior executive with Evonik, one of the largest specialty chemicals companies in the world, with a market capitalization of €14B and 32,000 employees.



Josephine Bush
Non-Executive Director

Member of the EY Power and Utilities Board. Led and delivered the EY Global Renewables and Sustainable Business Plan and spearheaded a series of major Renewable Market Transactions. Successfully advised on the first environmental yieldco London Stock Exchange listing, Greencoat UK Wind PLC. Ms. Bush is a Chartered Tax Advisor, holds an MA Law degree from St Catharine's College, Cambridge, and brings a wealth of experience in ESG strategic advisory.

A wealth of multi-disciplinary experience across the span of industries that we cover



Gender-balanced, majority-independent Board of Directors



Dr. Günter Hilken
Non-Executive Director

Dr. Hilken has over 35 years' experience in and a deep understanding of the German chemicals, renewables and infrastructure investment sectors and, through leading industry advocacy associations, the German Government at the State and Federal level. Dr. Hilken is a Senior Advisor to Macquarie Asset Management, Director of Currenta and President and Chairman of the Board of the German Federation of Industrial Energy Consumers (VIK).



Mark Skelton
Non-Executive Director

Mr Skelton has more than 35 years' experience including a 29-year tenure at BP and then at Fortescue Metals Group (Fortescue) in Project Development and general management. A senior leader and advisor with a proven record in delivering major projects, business transformation and developing organisational capability within the mining, energy and oil and gas industries, Mr Skelton has extensive project experience in Australia and internationally.

APPENDIX 2: SHARE PRICE AND CAPITAL STRUCTURE

ASX : VUL

Shares on Issue	143,435,301
Performance Shares	91,174
Performance Rights	8,742,801
Market Capitalisation at \$7.16 (undiluted as at 10 February 2023)	~\$1.03B
Cash Position (as at 31 Dec 2022)	€134M
Top 20 Shareholders	~61%
Management (undiluted)	~17%

Frankfurt: VUL

KEY SHAREHOLDERS

Dr. Francis Wedin and related parties	11.50%
Stellantis Group (PSA Automobiles)	8.00%
Vivien Enterprises Pte Ltd	5.77%
Hancock Prospecting Pty Ltd	5.64%

VUL SHARE PRICE (AUD) (1 MAR 2022 – 1 FEB 2023)

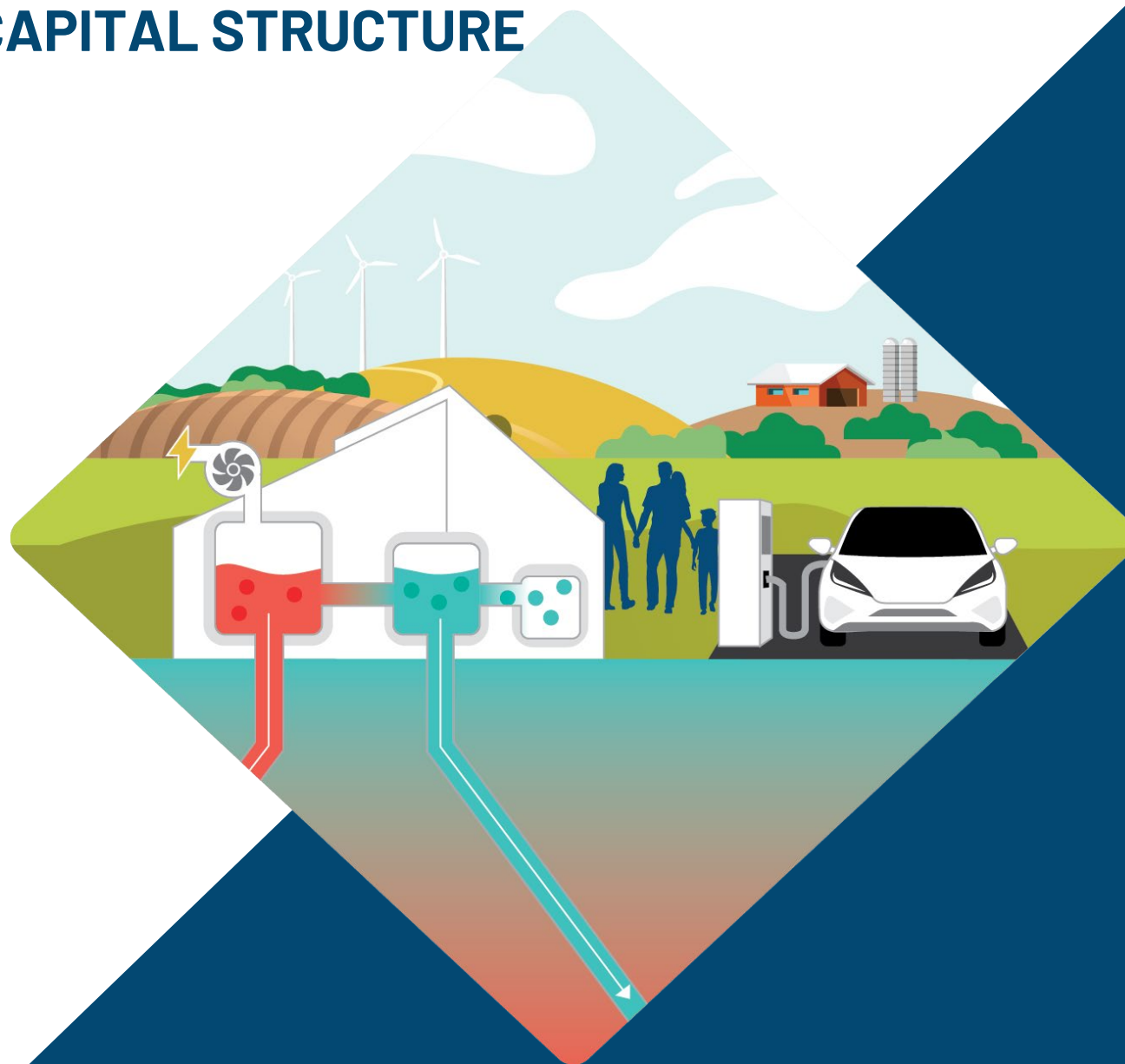
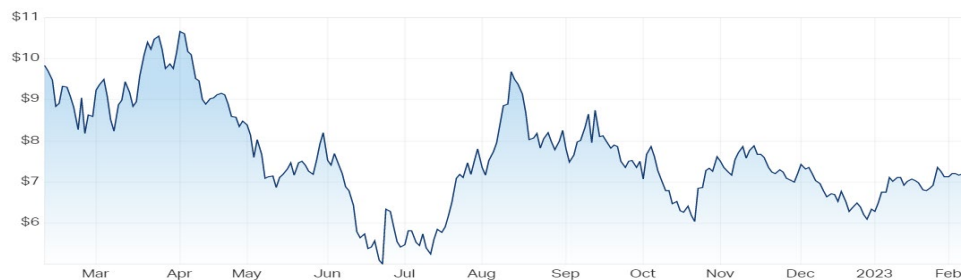

APPENDIX 3: DLE/DLS PROJECTS AND ASSETS - REFERENCES

Livent	https://s22.q4cdn.com/453302215/files/doc_presentations/2022/2022.11-Livent-Investor-Presentation.pdf
Lanke Lithium	https://www.linkedin.com/pulse/from-catamarca-qinghai-commercial-scale-direct-lithium-alex-grant/ http://www.asianmetal.com/news/1665421/Lanke-lithium-plans-to-launch-commercial-production-of-battery-grade-lithium-carbonate
Zangge Lithium	https://www.linkedin.com/pulse/from-catamarca-qinghai-commercial-scale-direct-lithium-alex-grant/
Jintai Lithium	https://www.linkedin.com/pulse/from-catamarca-qinghai-commercial-scale-direct-lithium-alex-grant/
Eramet/Tsingshan	https://www.eramet.com/sites/default/files/2022-05/2022-05-Eramet%20Investor%20Presentation-May%202022.pdf
Standard Lithium	https://www.standardlithium.com/projects/arkansas-smackover
Vulcan Energy	https://v-er.eu/wp-content/uploads/2021/12/2021-AGM-MD-presentation.pdf
Rio Tinto	https://www.rinconmining.com/wp-content/uploads/2021/10/Rincon-FINAL-E-210921-FINAL.pdf
CTR	https://www.cthermal.com/projects
Berkshire Hathaway	https://www.ft.com/content/c9760a4e-1a76-11e9-9e64-d150b3105d21
Lake Resources/Lilac	https://lakeresources.com.au/wp-content/uploads/2023/01/lke_kachi-resource_11-jan-23.pdf
Compass Minerals	https://s22.q4cdn.com/834578860/files/doc_presentations/2022/12/DB-Lithium-Battery-Supply-Chain-Conf-v4-(12.02.22).pdf
E3 Metals	https://www.e3lithium.ca/_resources/presentations/corporate-presentation.pdf?v=0.084



APPENDIX 4: EUROPEAN LITHIUM PROJECTS PEER COMPARISON REFERENCES

COMPANY ¹	CODE	PROJECT	STAGE	RESOURCE CATEGORY	RESOURCES M ONNES	RESOURCE GRADE (LI2O)	CONTAINED MT LCE TONNES	INFORMATION SOURCE
European Metals	ASX: EMH	Cinovec	PFS Complete	Indicated & Inferred	708.2	0.43	7.39	Annual Report June 22
Rio Tinto	ASX: RIO	Jadar	PFS Complete	Indicated & Inferred	144	1.80	6.12	Annual Report Dec 21
Infinity Lithium	ASX: INF	San Jose	PFS Complete	Indicated & Inferred	111.2	0.61	1.68	Annual Report June 22
Savannah Resources	AIM: SAV	Barroso	DFS Underway	Measured, Indicated & Inferred	27.0	1.06	0.71	Corporate Presentation December 2022 – Company Website

Note 1: Data provided for lithium focused peers with comparable project size and stage and published resource information



APPENDIX 5: EUROPEAN MACRO POLICY TAILWINDS IN VULCAN'S FAVOUR



European Commission President, Ursula von der Leyen

Ursula **von der Leyen**, President of the European Commission, said: *"We have a once in a generation opportunity to show the way with speed, ambition and a sense of purpose to secure the EU's industrial lead in the fast-growing net-zero technology sector. Europe is determined to lead the clean tech revolution. For our companies and people, it means turning skills into quality jobs and innovation into mass production, thanks to a simpler and faster framework. Better access to finance will allow our key clean tech industries to scale up quickly."*⁴

1 February 2023

European Policy Development



- Green Deal Industrial Plan
- New EU Battery Regulation
- Carbon Border Adjustment Mechanism
- Battery Passport
- ISO/TC 333 Lithium
- European Battery Alliance
- Critical Raw Materials List
- EIB new energy lending policy
- European Raw Materials Alliance

EV Mobility Transition

By the end of 2030 Europe aims to cut CO₂ emissions from cars by 55% and vans by 50%.

By 2035 the EU proposes to completely cut emissions from cars and vans. *A significant increase in the uptake of electric vehicles will be needed to achieve these goals.*⁵

Germany is aligned to the EU targets and has also set a target for 15 million EV's in the road by 2025.⁶

Commitments from our EV partners



100% of sales in Europe and 50% of sales in the United States to be battery electric vehicles (BEVs) by the end of this decade. We plan to have more than 75 BEVs and reach global annual BEV sales of five million vehicles by 2030.³



Volkswagen aims to be 100% carbon-neutral by 2050. Volkswagen's goal for 2030 is to reduce emissions per vehicle in Europe by 40 percent compared to 2018.¹

RENAULT GROUP

Reducing CO₂ emissions in use (tailpipe & fuels production) by 50% by 2030 in Europe. Reach zero CO₂ in Europe by 2050.²

¹<https://www.volkswagen-newsroom.com/en/on-the-way-to-zero-the-general-strategy-7226>

²<https://www.renaultgroup.com/en/our-commitments/respect-for-the-environment/carbon-footprint/>

⁴https://ec.europa.eu/commission/presscorner/detail/en/IP_23_510

⁵<https://www.eea.europa.eu/ims/new-registrations-of-electric-vehicles>

³<https://www.stellantis.com/en/news/press-releases/2022/march/dare-forward-2030-stellantis-blueprint-for-cutting-edge-freedom-of-mobility>

⁶<https://www.globaldata.com/media/power/german0electric-vechiles>

APPENDIX 6: KEY RISKS TECHNOLOGY / EXECUTION / RESOURCE

Risk Description	Mitigation
Technology: VULSORB™ industrial manufacturing capability still to be demonstrated.	Currently in discussions with a local toll manufacturer to manufacture VULSORB™, who is already supplying Vulcan for its Demo Plant. Similar to other sorbents which have also been tested in Vulcan's pilot plants, are commercially available and could be used instead.
Technology: VULSORB™ + HP Operation has limited pilot scale testing so far.	If HP Operation is not seen as successful, the Project can revert back to the proven LP mode of Operation, which has many thousands of hours of successful testwork.
Technology: Electrolysers – widely used in salts industry but not yet commercially used on lithium salts.	Extensive Demonstration Plant testwork conducted by NORAM and other companies on LiCl electrolysis over many years. Planned to be further backed up by operational tests in Electrolysis Demo Plant, using a commercial scale electrolyser, which is aimed to optimise process parameters and operating conditions.
Technology: Demo Plant operational data after design freeze in April could lead to change during Bridging or Execution Phase	Extensive pilot plant data already provides some risk mitigation. Expedite Demo Plant data during bridging and execution to optimise process parameters and operating conditions.
Execution: Delay in order of Long Lead Items (LLI) of Equipment packages and award of EPC/EPCm contracts and further supply chain issues	All LLI have been identified and clear schedule to be awarded and clear advancement of vendor data to support 3D model to achieve 60% model review ASAP. Bridging moving to E&P Phase rather than just Engineering and clearly identified LLI and award of EPCm, see Hatch updated Bridging phase scope and deliverables.
Execution: Some critical decisions by authorities on permitting pathway – risk of delay. There is no guarantee that Vulcan Group will be able to obtain all required approvals, licences and permits for lithium and geothermal renewable energy production in time or at all.	Proactive engagement with authorities, selection of sites outside of environmentally sensitive areas.
Execution: Brine production expansion drilling programme dependent on continued success of land purchase, permits and then significant ramp up in capability and capacity.	Proactive engagement with local stakeholders and authorities, focus on first areas in schedule
Execution: Bridging phase is front-end loaded with numerous intensive and parallel work streams including approvals, engineering, contracts and procurement, financing to meet early milestones and protect overall execution phase.	Project Directorate in place and on the ground, Integrated Level 2 schedule now developed showing key links between projects and what risk and workstream pushes what
Execution: Speed and ramp up of Project Execution teams to deliver projects	Vulcan group rolling out transition to Functional Organisation with Execution focus, Project Directorate and other key roles identified and recruitment ongoing
Execution: The target execution schedule (27 months from detail design to start of production) is a tight schedule	27 months is well benchmarked across other key Battery related projects in Europe and globally, key execution risks need mitigating early on and supported by early decision making
Economics: FX EUR/USD: all LHM offtakes are linked to a PRA with a USD index or a fixed price in USD	Commercial team to explore converting offtakes to EUR-linked pricing index when the European lithium market matures.
Economics: DFS CAPEX estimate is combination of Class 3 (+/-15%), accuracy and Order of Magnitude accuracy for the late Value Improvements.	DFS Phase took budgetary quotes at the top of the commodity cycle with high inflationary conditions. Key budgetary quotes related to HP mode equipment were re-budgeted by suppliers and included in DFS Cost Estimate. Contingency and Design Allowance are included where applicable. These opportunities are planned to be developed to the same detail and accuracy as the original estimate during Bridging and an Open Book Estimate (OBE) approach is planned to be used during Bridging to understand trends against DFS.
Resource: Brine flow rate risk	Due to field development plan simulation results, lower “per well” brine flow rate has been shown to be more optimal for lithium sweep, therefore more conservative brine flow rate assumptions have already been used, of 69l/s average (>100l/s in PFS). This is in line with the Vulcan's current geothermal wells and plant in operation. Use of 3D seismic targeting fault zones correctly and optimised for flow are expected to further reduce risk. Finally, measures such as side-track/double-completion drilling can be used to increase flow rates.
Resource: Unforeseen geological conditions impacting total resource	Integration of 3D seismic data into work plan. Expedite new production/re-injection well drilling to further reduce risk.
Resource: Seismicity events during ramp up of the field	Incorporate experience of the team in managing seismicity from Vulcan's existing geothermal operations, including extensive monitoring and “traffic light” system of warnings. Manage ramp-up sensibly and conduct best practice seismicity risk studies prior to commencing ramp up.

APPENDIX 7: KEY RISKS GENERAL

Risk Description	Mitigation
Markets: General demand for lithium hydroxide may decrease as a result of new market or technological developments and other factors. Any such factors resulting in a decrease in the general demand for lithium hydroxide may have a detrimental effect on Vulcan Group's business.	Vulcan closely monitors developments in the battery industry, and preferred battery chemistries. Vulcan notes that, whilst EU customers are investing in battery manufacturing which requires lithium hydroxide, other current battery types such as LFP use lithium carbonate, which Vulcan can switch the back-end of its process to making with relative simplicity. Future battery-types, such as solid state, use LiCl, which Vulcan produces as a precursor, giving flexibility.
Geopolitical: The Russian invasion of Ukraine, the sanctions imposed by numerous countries and international organizations in response thereto and countermeasures implemented by Russia have adversely affected, and may continue to adversely affect, the availability and price of equipment, components and energy, supply chains, international trade, financing conditions and the global economy at large, which has had, and may continue to have, a detrimental effect on Vulcan Group's business.	Vulcan has the ability to produce most of the power it needs and consume it internally, so is somewhat insulated from sharp price increases in power. Vulcan does not directly consume any fossil fuels, providing further mitigation. Vulcan will seek to work with suppliers to mitigate effects of equipment and materials price fluctuation, however there may still be supply chain interruptions and increases in the cost of equipment.
ESG: Vulcan Group may fail to achieve its sustainability ambitions or fail to maintain current or obtain potential future ESG ratings and sustainability-related certifications, each of which could have a material adverse effect on its business, assets, results of operations, financial condition, prospects and reputation.	Vulcan has appointed a Head of ESG and has a Board Director with very extensive ESG-related experience. Vulcan engages with expert third party consultants, including ERM and Baringa, to provide up to date advice on the changing ESG landscape, to ensure it maintains its status as an ESG-leader. In addition, Vulcan is ensuring that sustainability related topics are embedded within its engineering and procurement practices including setting executive individual and group KPI's with ESG baseline metrics.
Markets: Lithium prices are subject to unpredictable fluctuations, driven in part by changes in the balance of global supply and demand as well as international, economic and geopolitical trends and developments. Any decrease or significant volatility in the price of or demand for lithium could have a detrimental effect on Vulcan Group's business.	Vulcan has put in place a series of binding, take or pay lithium hydroxide offtake agreements for the first five years, and in one case the first ten years, of production. These offtake agreements are based on a basket of different mechanisms, providing some downside protection against lower prices. Vulcan is also targeting a very low OPEX, meaning it would be somewhat protected against lower prices.
Markets: Any decrease in the price or demand for geothermal energy may have a detrimental effect on Vulcan Group's business.	The portion of revenue derived from geothermal energy in Vulcan's financial model is very minor. In addition, Vulcan expects to sell power under a 20 year feed-in tariff under the German Renewable Energy Law. Finally, because Vulcan is a consumer as well as a seller of energy, the effect of lower prices would also be offset by lower OPEX costs.
Financial: Significant future funding will be required by Vulcan Group to support the further implementation of its Zero Carbon Lithium™ Project. If Vulcan Group is unable to obtain additional financing as needed on acceptable terms or at all, it may need to abandon its development plans or reduce and/or change their scope which may, in turn, adversely affect Vulcan Group's operations.	Vulcan is taking a multi-pronged approach to financing, which involves assessing the possibility for equity financing at a project level (geothermal, lithium extraction, lithium refining, or a combination), equity financing at a top-co level, debt financing and grant funding from public bodies. Vulcan is working with a multi-disciplinary team at BNP Paribas on a debt financing process, and has already attracted non-binding letters of intent from Export Credit Agencies in Europe. Vulcan is expecting support at a German Federal and European level. Additionally, Vulcan aims to be supported by its existing shareholders, including institutional investors and large corporates.
Technical: The resource estimates relating to Vulcan Group's current and future projects are subject to certain assumptions and interpretations which may prove to be inaccurate. Any material deviations may result in alterations to development plans which may, in turn, adversely affect Vulcan Group's operations.	Vulcan plans to regularly update its models as it gathers new data, including from the drilling of development wells in the Phase One areas, the sampling of brines from these wells, logging of core, and 3D seismic acquisition and processing. Resource estimates are planned to therefore be updated and refined accordingly, allowing Vulcan to progressively mitigate the risk as the project develops.
Financial: As it is envisaged to incur significant debt in the future, an increase in interest rates would likely increase Vulcan Group's costs for its future debt financing arrangements.	Because of its sustainability credentials, Vulcan expects to qualify for so-called "green financing", which can involve a reduced borrowing interested rate. This would provide some mitigation for rising interest rates. In addition, Vulcan is in discussions with European public funding institutions, including the lending arm of the EU and Export Credit Agencies.
Legal: Vulcan Group might be unable to adequately protect its intellectual property rights.	Vulcan has a granted utility patent and several patents pending, as well as granted and pending trademarks in a number of jurisdictions. Vulcan will continue to engage expert IP counsel to protect its rights going forward.

APPENDIX 7: KEY RISKS GENERAL CONT.

Risk Description	Mitigation
<p>Technical: Battery raw materials and geothermal energy exploration and development are high-risk undertakings and there is no assurance that Vulcan Group's exploration activities will result in the commercial extraction of lithium or sustainable production of geothermal renewable energy.</p>	<p>Vulcan uses modern geothermal industry best practice by incorporating 3D seismic data and analysis and has a world class team, with considerable local geological expertise to advance its exploration and consequently its production to progress towards sustainable production.</p>
<p>Social acceptance: Vulcan's projects may face opposition from local residents and other stakeholders, which may result in delays, additional costs, discontinuation of construction or operations and uncertainty.</p>	<p>All large-scale infrastructure projects require strong community engagement to ensure any concerns are addressed. Vulcan takes this extremely seriously and has resourced an experienced public and stakeholder relations team with deep local knowledge. We use geothermal industry best practice, and we are commencing community engagement in the various areas where we intend to develop projects. Our current engagement to date, which clearly and transparently explains our process to develop renewable heat and power, combined with sustainable lithium extraction has informed our view that we will achieve stakeholder acceptance and manage delays.</p>
<p>Loss of key personnel: Vulcan may lose its directors or other key personnel or may be unable to recruit or retain qualified personnel for key positions. Without such directors or key personnel Vulcan Group may not be able to successfully manage, develop and operate its business</p>	<p>Vulcan strives to create a safe, attractive, rewarding and engaged workplace to retain and incentivise its staff, including regularly engaging with staff through surveys and external remuneration consultants in an attempt to maintain this environment.</p>



APPENDIX 8: MODERN LI-BRINE PROJECTS CHOOSING DIRECT LITHIUM SORPTION (DLS)

Company ¹	Livent	Lanke Lithium	Zangge Lithium	Jintai Lithium	Eramet/ Tsingshan	Vulcan Energy	Rio Tinto	Compass Minerals	Berkshire Hathaway	Energy Source Minerals	CTR	Standard Lithium	Lake Resources/ Lilac	E3 Lithium
Asset name	Hombre Muerto	Qinghai	Qinghai	Qinghai	Centenario-Ratonos	Zero Carbon Lithium™	Rincon	Great Salt Lake	Salton Sea	ATLiS	Hell's Kitchen	Smackover	Kachi	Clearwater Lithium
Jurisdiction														
Lithium extraction technology	Sorption	Sorption	Sorption	Sorption	Sorption	Sorption	Sorption	Sorption	Sorption	Sorption	IX	IX	IX	IX
Technology provider	Proprietary	Undisclosed	Undisclosed	Undisclosed	Proprietary	Proprietary: VULSORB™	Undisclosed	ILiAD	Proprietary	Proprietary ILiAD	Lilac	Proprietary LiSTR	Lilac	Proprietary
Tech origin														
Geothermal	✗	✗	✗	✗	✗	✓	✗	✗	✓	✓	✓	✗	✗	✗
Start date	1998	2017	2018	2019	Construction	Development	Development	Feasibility	Feasibility	Feasibility	Development	Development	Development	Feasibility
Capacity (ktpa LCE)	50	20	20	7	24	48 ²	50	35	90	20	25	21	25	20
Zero fossil fuels in flow sheet	✗	✗	✗	✗	✗	✓	✗	✗	✗	✗	✗	✗	✗	✗
Disclosed strategic investments					Tsingshan \$375M 11/2021	Institutional Investors A\$320M ('21) Stellantis A\$76m ('22)	Rio Tinto \$825M 12/2021	Koch \$252M			GM \$?M 07/2021	Koch \$100M 11/2021	Lilac Up to \$50M 09/2021	Canadian Government \$27M
Offtakes (announced publicly)	 	✗	✗	✗	✗	 	✗	✗	✗	✗	 	✗	✗	✗

¹Refer to Appendix 3: Lithium Brine Projects and Assets – References. ²Based on 24ktpa for each of Phase 1 (from DFS) and 2 (from PFS) See Vulcan Integrated PFS announcement, Jan 2021. Values from PFS are lower confidence than the DFS and should be treated with caution until they are updated with more recent data. Note technical information disclaimer on slide 4

APPENDIX 9: PHASE ONE PRODUCTION STUDY AND RESERVES

- Detailed reservoir engineering and production simulation study conducted to achieve maximum “sweep” of lithium across the field.
- Planned well placement and brine flow rates optimised for sustainable lithium production over a long project life.
- Production simulation includes existing production wells within Phase One area and incorporates large database of well and seismic data.
- Simulation reviewed and audited by independent lithium brine specialists and O&G industry reservoir engineering experts².
- Phase One: 0.54Mt LCE Proven and Probable Reserves centered around production wells in core of the URVBF field.

Lionheart: INS, LAN, RND		
Reserves Classification	Lithium grade	Economic Reserves Volume at Wellhead Reference Point
	mg/l Li	tonnes LCE
Proved	181	196,353
Probable	181	153,546
TAR-KER		
		tonnes LCE
Probable	181	189,070

Phase One¹ Mineral Reserves Estimation

¹Phase 2 Reserves currently not updated since 2021 PFS, to be updated during current Phase 2 feasibility studies

²Refer to Competent Person Statement on slide 5.

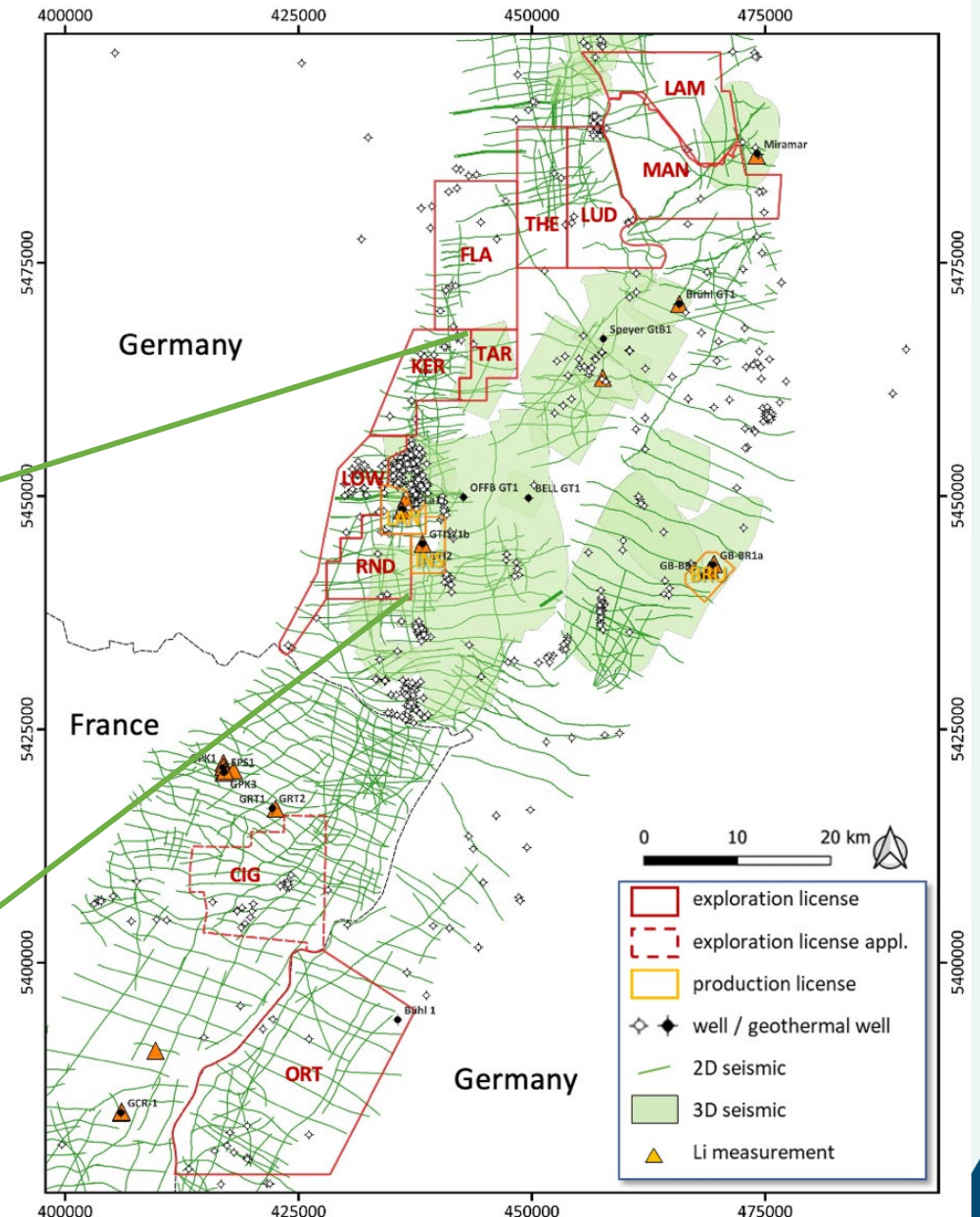

APPENDIX 10: UPPER RHINE VALLEY BRINE FIELD: MINERAL RESOURCE UPDATE



Licence	Reservoir	Classification	GRV km ³	Avg. NTG %	Avg. Phie %	Avg. Li mg/L	Elemental Li t	LCE ³ kt
Mannheim	BST	Indicated	4	90	10	153	54,111	288
	BST	Inferred	32	65	9	153	290,312	1,545
Ludwig	BST	Indicated	7	90	10	153	93,220	496
	BST	Inferred	22	65	9	153	199,226	1,060
Therese	BST	Indicated	2	90	10	153	29,907	159
	BST	Inferred	22	65	9	153	200,708	1,068
Flaggenturm	BST	Indicated	7	90	10	181	115,215	613
	BST	Inferred	37	65	9	181	391,201	2,082
Kerner	BST	Indicated	5	90	10	181	76,242	406
	BST	Inferred	13	65	9	181	132,558	705
Kerner (East)	*MUS, BST, ROT	Indicated	4.3	73	8	181	66,708	355
Taro	*MUS, BST, ROT	Indicated	14.5	73	8	181	237,362	1,263
Landau (South)	*MUS, BST, ROT	Measured	7.4	73	8	181	102,383	545
	BST	Indicated	1.2	90	11	181	22,220	118
Insheim	*MUS, BST, ROT	Measured	9	73	8	181	127,779	680
Rift (north)	*MUS, BST, ROT	Measured	10.1	73	8	181	134,132	714
	*MUS, BST, ROT	Indicated	11.9	73	8	181	178,000	946
Ortenau	*MUS, BST, ROT	Indicated	57	73	8	181	659,013	3,507
	BST	Inferred	105	73	8	181	1,883,212	10,024
Total LCE						mg/L		kt
		Measured				181		1,939
		Indicated				178		8,151
		Inferred				172		16,484

Note 1: Mineral Resources are not Ore Reserves and do not have demonstrated economic viability.
Note 2: The weights are reported in metric tonnes (1,000 kg or 2,204.6 lbs). Numbers may not add up due to rounding of the resource value percentages.
Note 3: Reservoir abbreviations: MUS – Muschelkalk Formation, BST – Buntsandstein Group; ROT – Rotliegend Group.
Note 4: To describe the resource in terms of industry standard, a conversion factor of 5.323 is used to convert elemental Li to Li₂CO₃, or Lithium Carbonate Equivalent (LCE).
Note 5: NTG and Phie averages have been weighted to the thickness of the reservoir.
Note 6: GRV refers to gross rock volume, also known as the aquifer volume.
Note 7: Mineral Resources are considered to have reasonable prospects for eventual economic extraction under current and forecast lithium market pricing used in the DFS with application of Vulcan's DLS processing.

PHASE ONE

Total URVBF Resource: Inferred 16.5Mt LCE @ 172mg/l Li, Indicated 8.2 Mt LCE @ 178 mg/l Li, Measured 1.94 Mt LCE @ 181 mg/l Li.
Total Phase One Resource (Measured and Indicated): 4.6 Mt LCE @ 181 mg/l Li
Total Resource (all classifications): 26.6 Mt LCE @ 175 mg/l Li
Refer to Competent Person Statement on slide 5.

APPENDIX 11: PERMITTING PROCESS

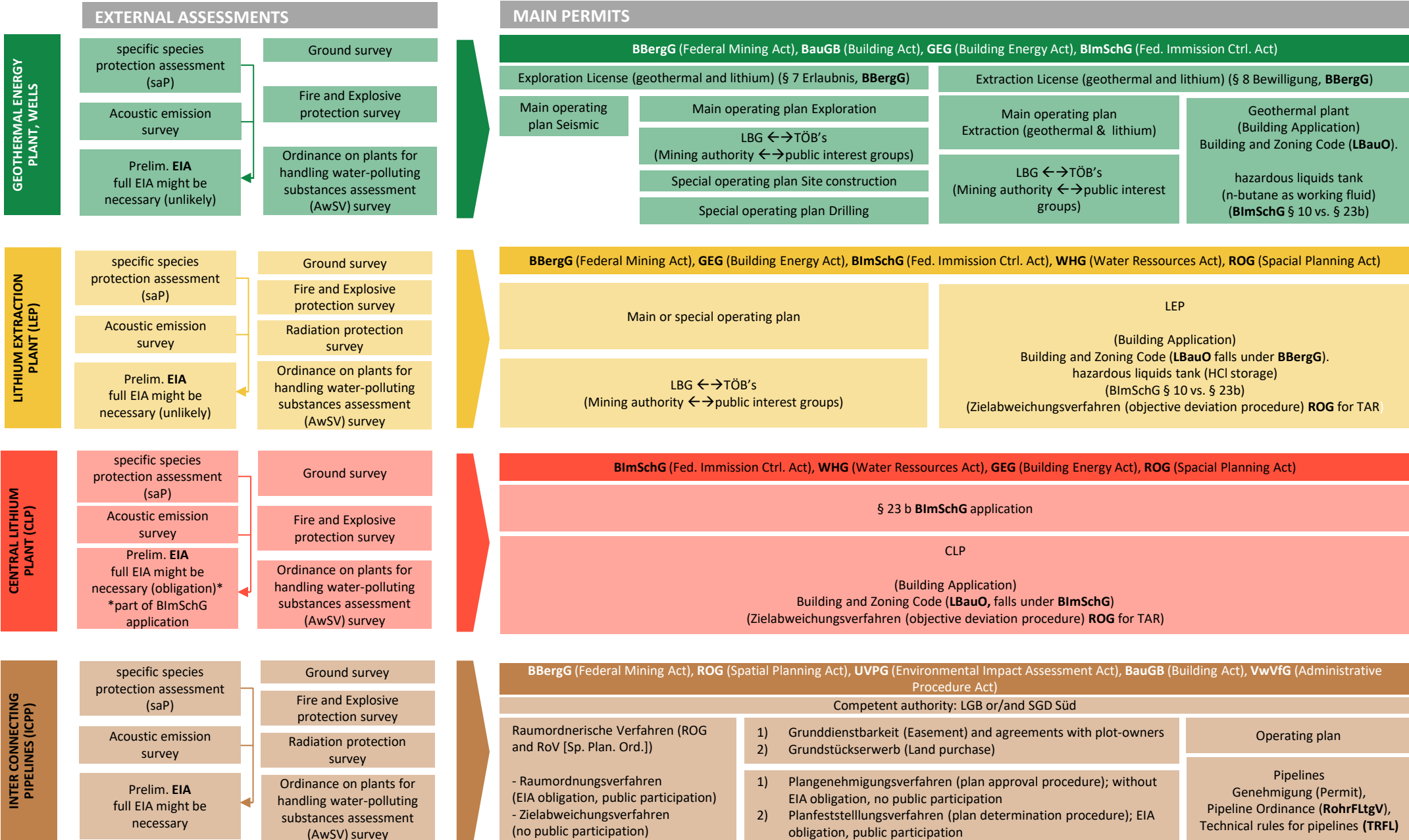

APPENDIX 12: INTEGRATED PROJECT DELIVERY MODEL

Strategy moving towards project execution and delivery model

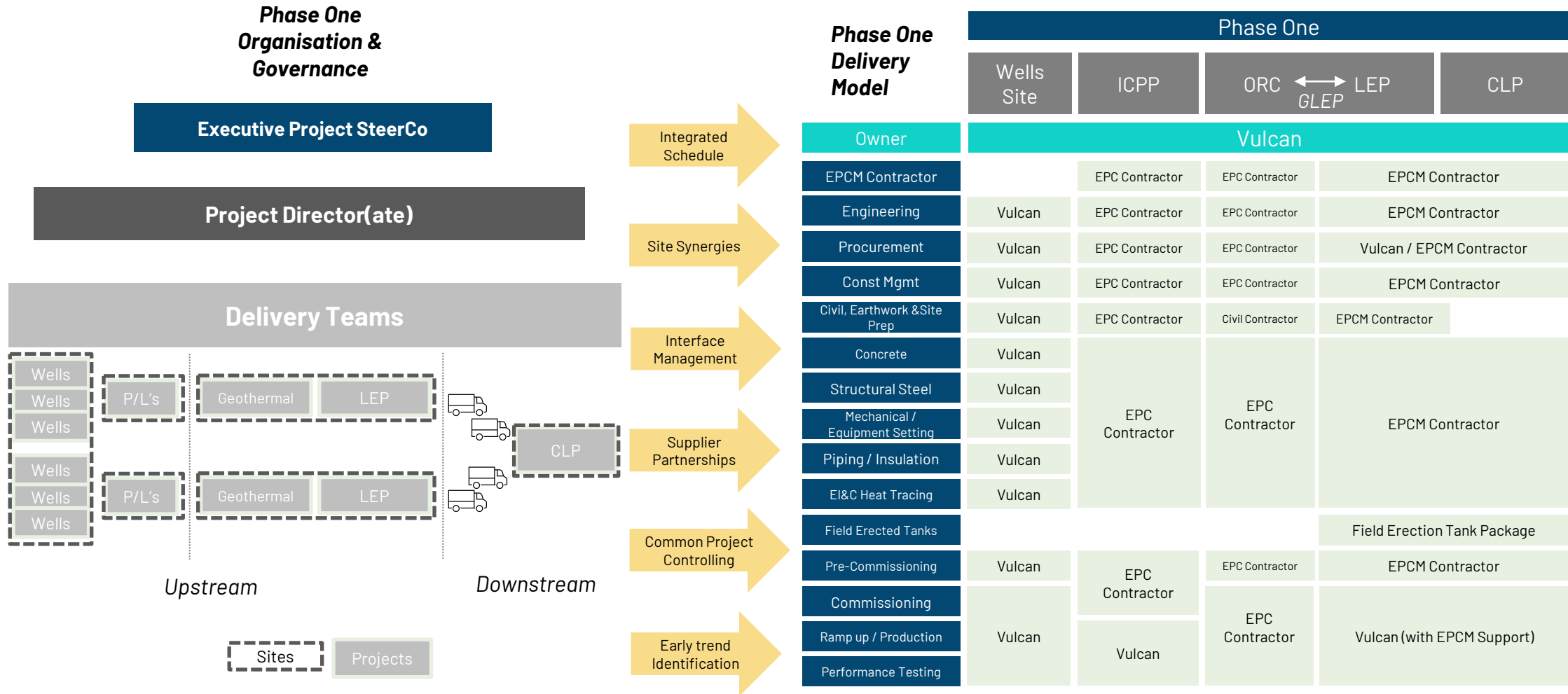

Well Sites Intermediate Heat Exchanger Piping System Geothermal Operations Lithium Extraction Transport Lithium Conversion End-market

LIONHEART SECTOR

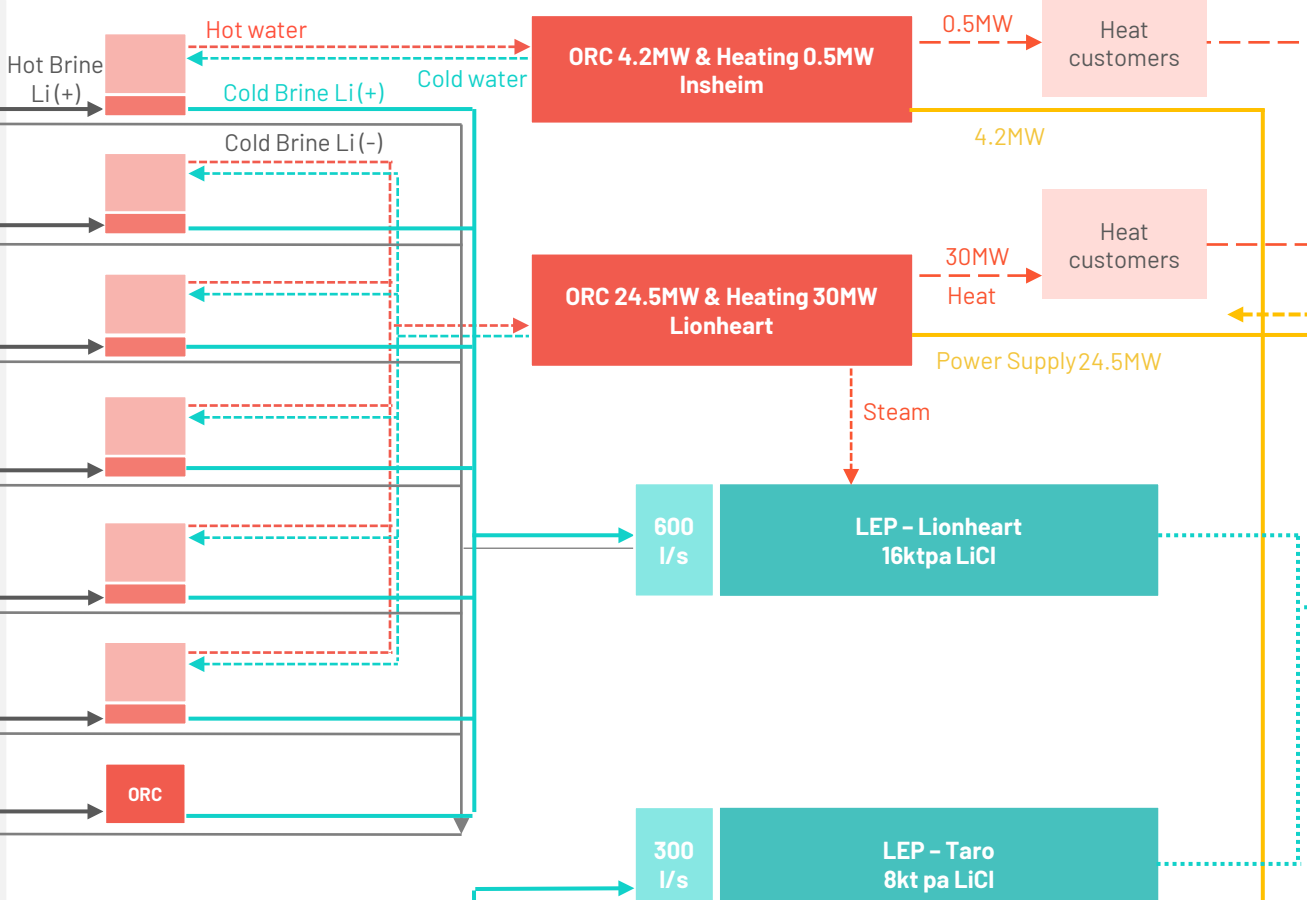
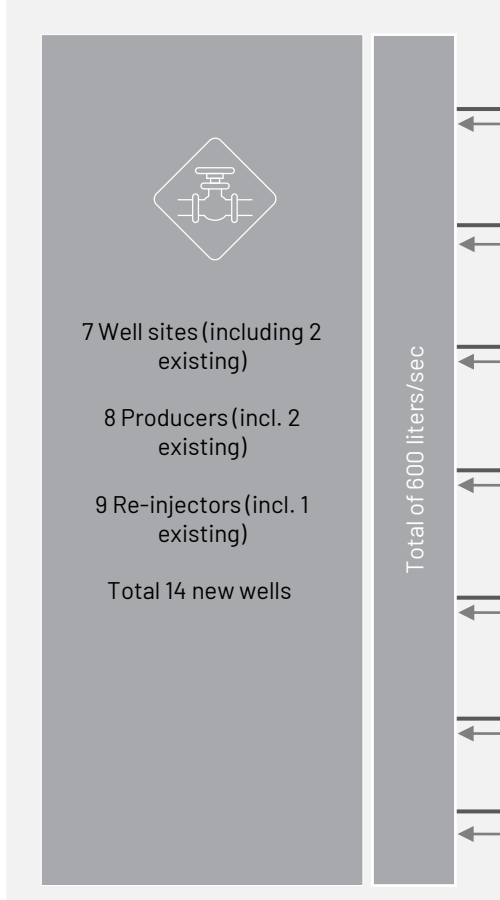

TARO SECTOR

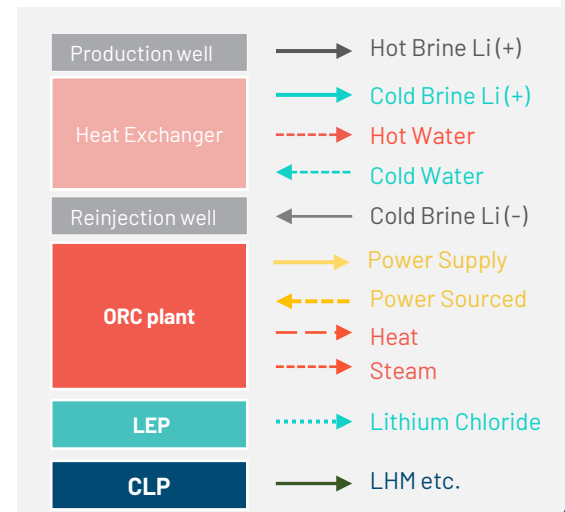
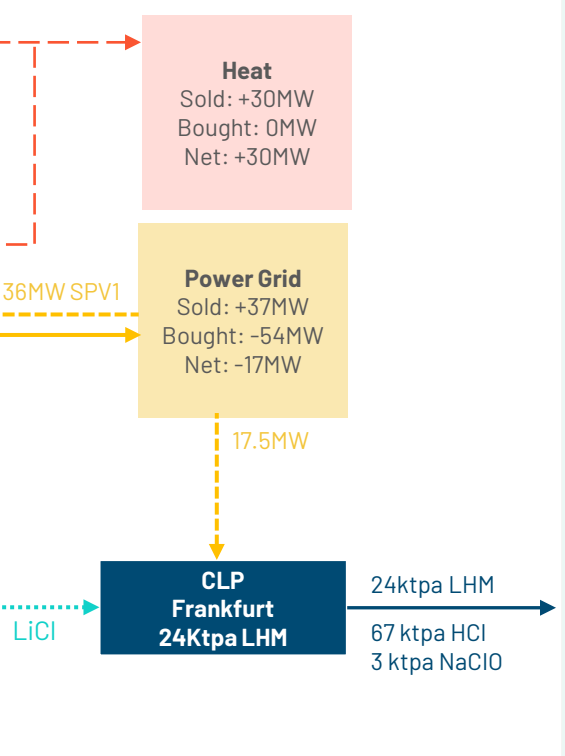
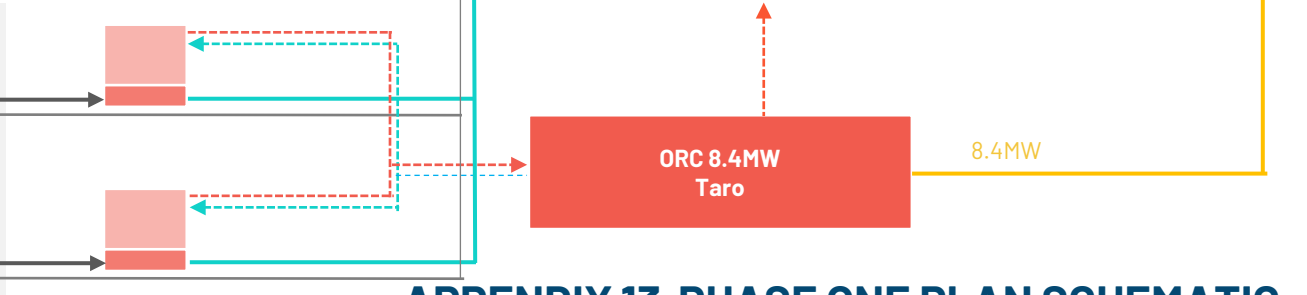
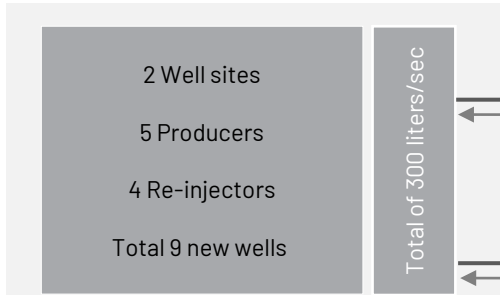

APPENDIX 13: PHASE ONE PLAN SCHEMATIC

Note: All numbers represent process flow modelling as part of Phase One plan.



APPENDIX 14: FINANCIAL DEFINITIONS

- CAPEX = Capital Expenditure in tangible and intangible assets
- EBIT = Earnings before interest and taxes
- EBITDA = Earnings before interest, taxes, depreciation and amortisation
- IRR = Internal Rate of Return
- Net Income (EAT) = Earnings after tax
- NPV = Net Present Value
- NPV_8 = Net Present Value using a discount rate of 8%
- OPEX = Operating expenditure including reagents, operating supplies, maintenance supplies, water, steam, nitrogen, energy, labour, trucking, services and other costs. Operating expenditure excludes corporate overhead costs for DFS Phase One purposes.
- Operating Margin = Profit on sales after costs of production, expressed as a percentage
- Payback = Period of time required for the return on an investment to repay the total initial investment

Note: These financial definitions are alternative performance measures that are not defined or specified under IFRS or AASC standards and for which there are no generally accepted reporting formats