

# Drilling confirms major helium system at North Rukwa Project.

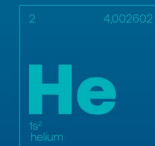

Shaun Scott  
Executive Chairman

January  
2024



# Disclaimer

This presentation has been prepared by Noble Helium Limited (ACN 603 664 268) (**Noble Helium or Company**) and contains background information about Noble Helium's current situation at the date of this presentation. The presentation is in summary form and does not purport to be all inclusive or complete. This presentation should be read in conjunction with the Company's other periodic and continuous disclosure announcements lodged with the Australian Securities Exchange.

Recipients should conduct their own investigations and perform their own analysis in order to satisfy themselves as to the accuracy and completeness of the information, statements and opinions contained in this presentation. This presentation is for information purposes only. Neither this presentation nor the information contained in it constitutes an offer, invitation, solicitation or recommendation in relation to the purchase or sales of shares or other securities in any jurisdiction. This presentation is not a prospectus, product disclosure statement or other offering document under Australian law (and will not be lodged with the Australian Securities and Investments Commission) or any other law.

This presentation does not constitute investment or financial product advice (nor tax, accounting or legal advice) and has been prepared without taking into account the recipient's investment objectives, financial circumstances or particular needs and the opinions and recommendations in this presentation are not intended to represent recommendations of particular investments to particular persons. Recipients should seek professional advice when deciding if an investment is appropriate. All securities involve risks which include (among others) the risk of adverse or unanticipated market, financial or political developments.

This presentation may include forward-looking statements. Forward-looking statements are only predictions and are subject to risks, uncertainties and assumptions which are outside the control of Noble Helium. Actual values, results or events may be materially different to those expressed or implied in this presentation. Given these uncertainties, recipients are cautioned not to place reliance on forward looking statements.

Whilst this presentation is based on information from sources which are considered reliable, no representation or warranty, express or implied, is made or given by or on behalf of the Company, any of its directors, or any other person about the accuracy, completeness or fairness of the information or opinions contained in this presentation. No responsibility or liability is accepted by any of them for that information or those opinions or for any errors, omissions, misstatements (negligent or otherwise) or for any communication written or otherwise, contained or referred to in this presentation. Neither the Company nor any of its directors, officers, employees, advisers, associated persons or subsidiaries are liable for any direct, indirect or consequential loss or damage suffered by any person as a result of relying upon any statement in this presentation or any document supplied with this presentation, or by any future communications in connection with those documents and all of those losses and damages are expressly disclaimed.

No reserves have been assigned in connection with the Company's property interests to date, given their early stage of development. Unrisked Prospective Helium Volumes have been defined. However, estimating helium volumes is subject to significant uncertainties associated with technical data and the interpretation of that data, future commodity prices, and development and operating costs. There can be no guarantee that Noble Helium will successfully convert its helium resource to reserves and produce that estimated volume.

## Competent Person's Statement

The prospective volumes are for helium, which are not hydrocarbons. However, Netherland, Sewell & Associates, Inc. have used the definitions and guidelines set forth in the 2018 Petroleum Resources Management System (**SPE-PRMS**) approved by the Society of Petroleum Engineers as the framework to classify these helium volumes as "prospective". The SPE-PRMS is specifically designed for hydrocarbons, which helium is not, however the principles and methods for hydrocarbon gas resource estimation are directly applicable to helium gas volume estimation.

The prospective helium volumes included in this presentation should not be construed as petroleum reserves, petroleum contingent resources, or petroleum prospective resources. They represent exploration opportunities and quantify the development potential in the event a helium discovery is made. The information in this presentation which relates to prospective helium volumes is based on, and fairly represents, in the form and context in which it appears, information and supporting documents prepared by, or under the supervision of, Alexander Karpov and Zachary Long .

Alexander Karpov is an employee of Netherland, Sewell & Associates, Inc. Alexander Karpov attended Texas A&M University and graduated in 2001 with a Master of Science Degree in Petroleum Engineering, and attended the Moscow Institute of Oil and Gas and graduated in 1992 with a Bachelor of Science Degree in Petroleum Geology. Alexander Karpov is a Licensed Professional Engineer in the State of Texas, United States of America and has in excess of 26 years of experience in petroleum engineering studies and evaluations. Alexander Karpov has sufficient experience to qualify as a qualified petroleum reserves and resources evaluator as defined in the ASX Listing Rules.

Zachary Long is an employee of Netherland, Sewell & Associates, Inc. Zachary Long attended Texas A&M University and graduated in 2005 with a Master of Science Degree in Geophysics, and attended the University of Louisiana at Lafayette and graduated in 2003 with a Bachelor of Science Degree in Geology. Zachary Long is a Licensed Professional Geoscientist in the State of Texas, United States of America and has in excess of 16 years of experience in geological and geophysical studies and evaluations. Zachary Long has sufficient experience to qualify as a qualified petroleum reserves and resources evaluator as defined in the ASX Listing Rules.

Alexander Karpov, Zachary Long and Netherland, Sewell & Associates, Inc. have each consented to the inclusion in this presentation of the matters based on this information in the form and context in which they appear.

# Green helium for a high-tech world.

A ground-floor investment in the potential discovery and development of the world's largest **green helium** reserve.

**01**  
Helium market is accelerating



**02**  
World class helium assets



**03**  
Proven helium system at North Rukwa



**04**  
Commercialisation coming into view



# There's no technology without helium.

It's an irreplaceable input for many important technologies with significant demand growth from manufacturers of semiconductors used in computers, mobile phones, cars, (even kids' toys).

The global helium market size is expected to grow from an estimated US\$5 billion in 2023 to over **US\$8 billion in 2030.**

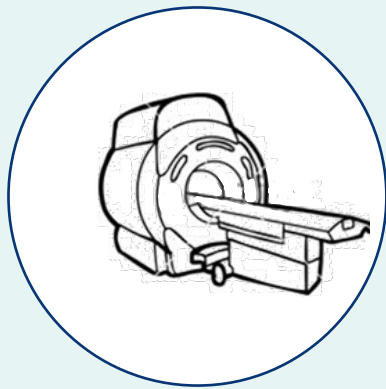

MRI 22%

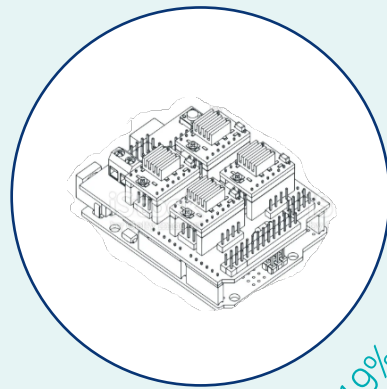

Electronics 19%

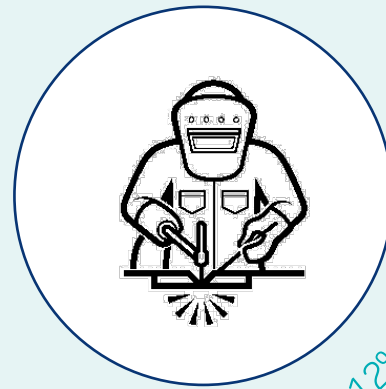

Metal fab 12%

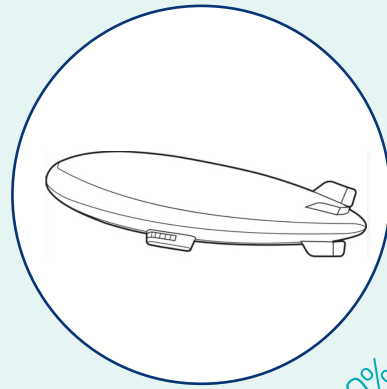

Lifting 10%

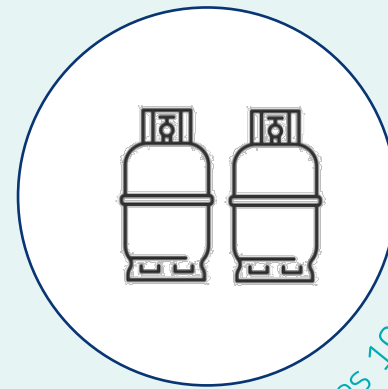

Spec Gases 10%

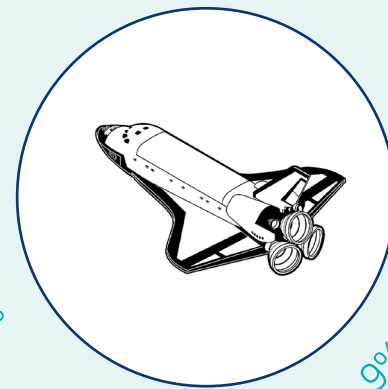

Aerospace 9%

## The high price of helium means a little makes a lot.

Revenue from 1,000 Mscf/day



As a gas, helium has similar exploration/ production costs per Mscf as traditional oil and gas.

Production required for \$1 million/day revenue

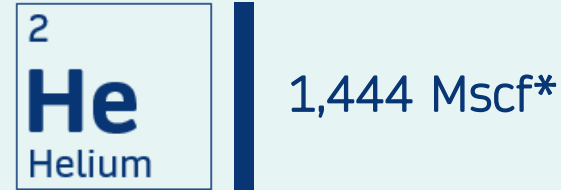

At the current pricing, we can get the same revenue as a domestic gas project with less than 2% of the helium production.

\*Long term bulk helium price of US\$450 at 0.65 conversion versus the current domestic gas cap of A\$12

# Mbelele: the beginning of the story not the end game!

The number of helium shows at all levels across both wells demonstrates that this is a prolific helium producing system.

- Mbelele 1 & 2 are the first two wells at the North Rukwa Project.
- Simple shallow vertical wells to start in a new remote basin.
- Only tested the Upper, Middle & Lower lake beds. The Nsungwe, Galula and Karoo are yet to be explored.
- The quantity and quality of the reservoirs exceeded expectations.
- Helium is extremely rare and there are few places in the world with the helium potential of the North Rukwa.

Noble has only explored the top third of the North Rukwa Basin and Mbelele represents only one of up to 10 leads.

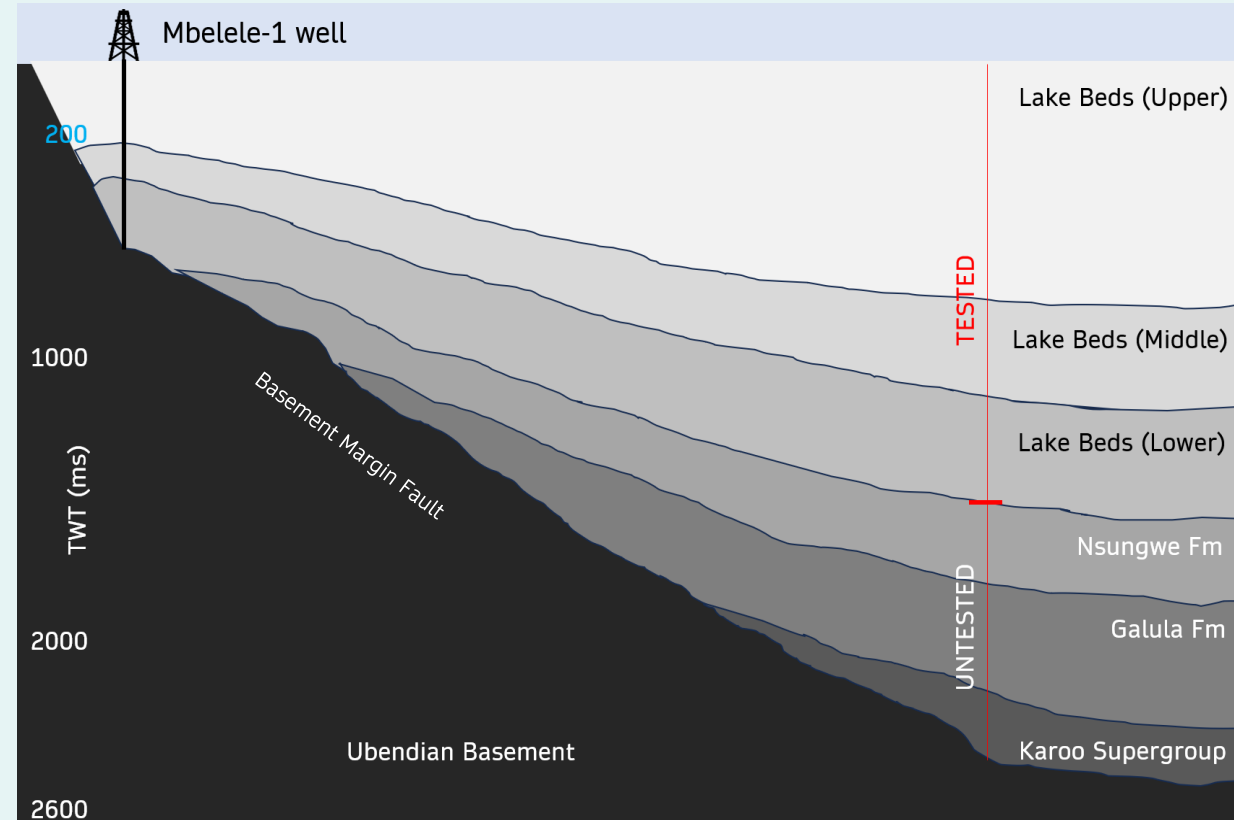

# Mbelele Prospect: what we've found.

- Probable 10-15m free gas cap around 85m.
- Multiple reservoir zones filled with helium-rich fluids at or very close to fully saturated.
- 47.5m net reservoir in Mbelele-1 and 163.0m net reservoir in Mbelele-2.
- Very high permeability and excellent porosity ie very high flow potential across all reservoirs.
- Helium concentration estimated at 2-3% from 223m sample. USA average concentration of 0.35%\*.

\*Source: CNN article dated 4 January 2024  
<https://www.cnn.com/2024/01/04/africa/renergen-helium-south-africa-spc-intl/index.html>

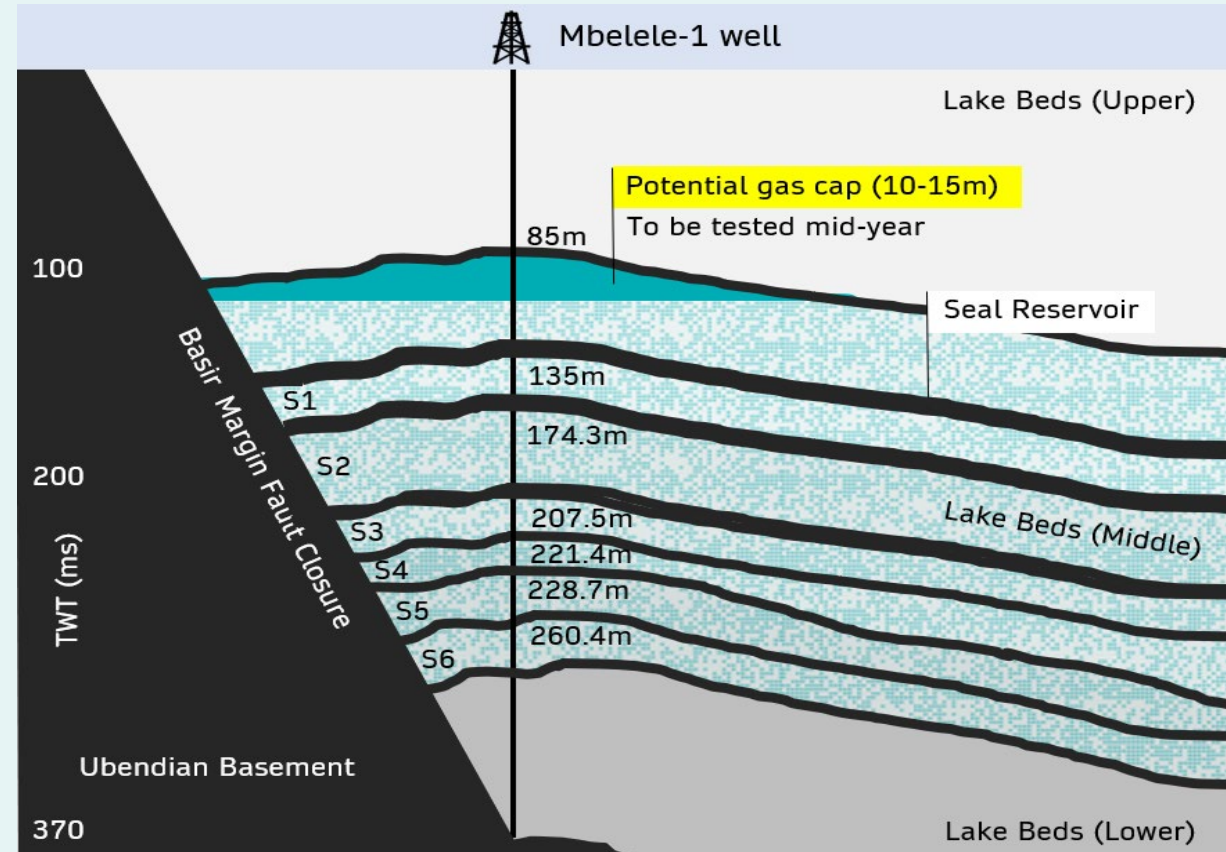

# What's next?

01

Lab results from well samples to confirm helium concentration and saturation levels.

02

Updating our Petrel model with the data gathered from the Mbelele wells.

03

Working with UQ to model the helium saturated.

04

Re-drill gas cap to obtain a gas sample and flow.

05

Small low-cost pilot to de-pressurise the helium saturated reservoirs and prove commercial flow rates.

06

Continue to mature additional targets within North Rukwa with a focus on the deeper untested targets.

07

Ongoing discussions with potential off-takers to monetise Mbelele.

Funding in place to achieve all of the below:





---

## Why test the helium saturated water?

---

01

Helium is a rare, critical, in demand industrial gas.

02

As noted early, we can get the same revenue as a gas project with less than 2% of the production.

03

Multiple on-site tests demonstrated that helium liberated quickly from the water samples with minor pressure reduction.

04

The water appears to be at or close to gas saturation i.e. as full as it can be of gas.

05

Lab results from well samples to confirm helium concentration and saturation levels – will be a critical input to our model.

06

Small low-cost pilot to de-pressurise the helium saturated reservoirs and prove commercial flow rates – will be a function of helium content, flow rate and well cost.

07

Water is the primary pathway for helium migration from source and the basin is full of helium saturated water, so the size of the prize is large.

## Early monetisation opportunity.

Negotiations advanced with potential off-takers to manage logistics and fund downstream facilities.

- Helium liquefaction plant on site with potential to process around **500mscf per day** (200,000mscf/year = 0.2Bcf/year). Only 2Bcf required for company-making 10-year contract.
- Simple, low-cost field development and gas gathering system.
- Off-taker would truck liquid helium iso-containers on black-top road to Port of Dar es Salaam.
- Direct access to national power grid and water.

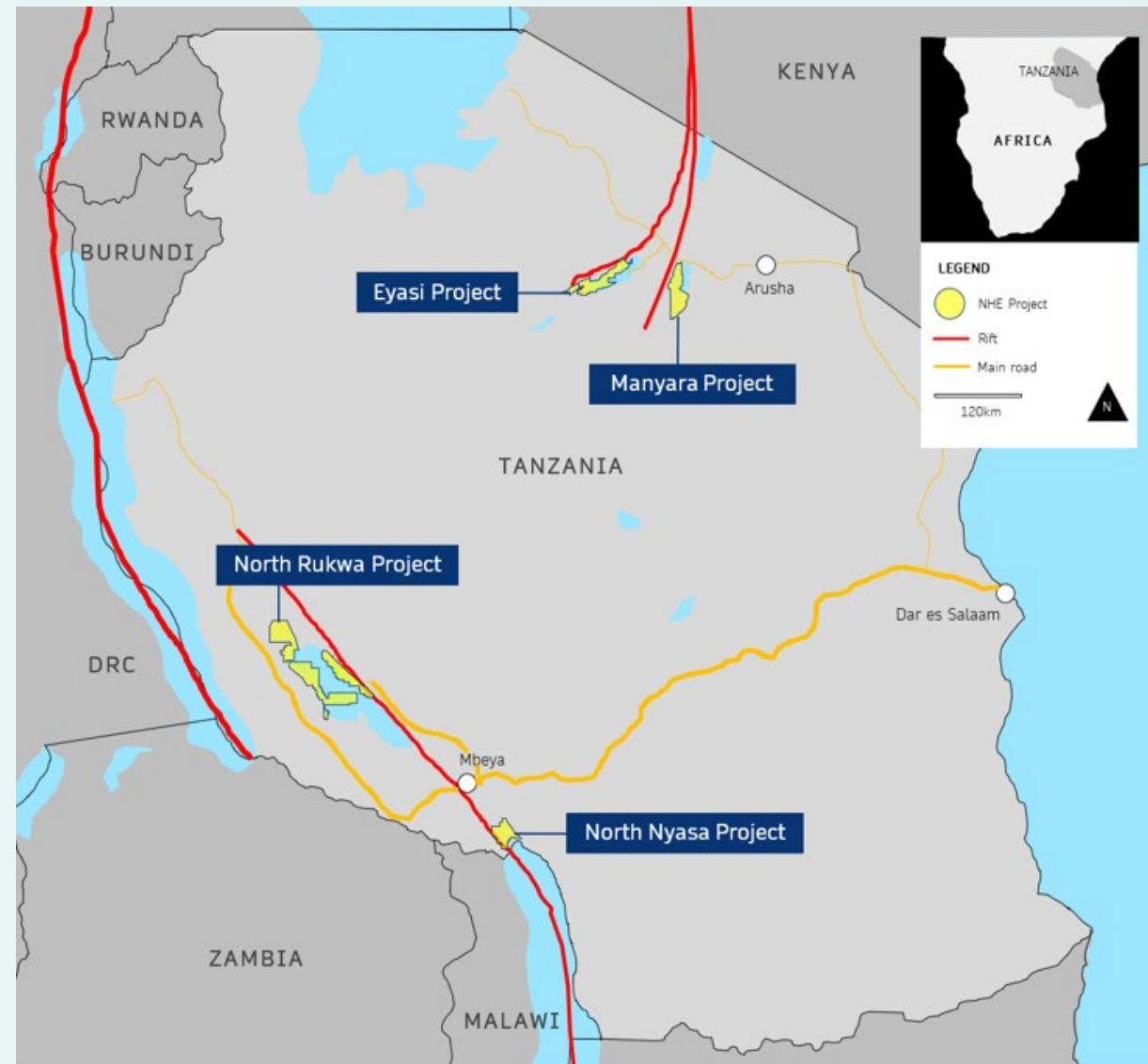

## We're also working with two of the world's foremost helium geoscientists.

Noble Helium commissioned, and has licensed, the world's first 'Helium Atlas' from Global Helium Resources, who's two foremost helium experts – Dr. Jon Gluyas of Durham University and Dr. Chris Ballentine of Oxford – were key in its development.

- A detailed study of all the helium prospects in the world.
- The Atlas has confirmed Tanzania as likely to host the best helium prospects in the world.
- Access to Drs Gluyas and Ballantine and the 'Helium Atlas' will also help Noble Helium in selecting future helium project acquisitions.

We're writing the book on helium. **Literally.**



# Noble Helium is led by experienced oil and gas pioneers.



**Shaun Scott**  
Executive Chairman

Helped pioneer Queensland coal seam gas industry from “novelty” status to a \$20 billion per year export industry.

As CEO of Arrow Energy Ltd, Shaun led the growth of that business from a \$20m coal seam gas explorer until its \$3.5 billion acquisition by Shell and Petro-China.

Highly experienced independent non-executive director on publicly listed and private company boards. Currently a non-executive director of ASX listed Comet Ridge Ltd.



**Justyn Wood**  
Chief Executive Officer

The Exploration Geophysicist who helped put the East African Rift System on the world oil and gas map.

Justyn has nearly 30 years of E&P industry experience in both technical and management roles at Hardman Resources, Chevron Australia, Repsol Australia and Oil Company of Australia.

Made key contributions to the first oil discoveries in South America’s Guyana margin as well.



**Prof Andrew Garnett**  
Non-Executive Director

Prof. Garnett is currently the Director of the University of Queensland’s research Centre for Natural Gas (CNG), working closely with the main LNG project proponents in Queensland, Australia. Has over 25 years of international experience in senior technical, management and executive roles in the upstream oil and gas sector including with Shell and Schlumberger.



**Eddie King**  
Non-Executive Director

Former investment banker and current director of CPS Capital Group, a stockbroking and corporate advisory firm specialising in small to medium high growth companies. Executive Chairman of Rubix Resources Ltd (ASX: RB6), Executive Director of Ragnar Metals Ltd (ASX: RAG), Non-Executive Chairman of Bindi Metals Ltd (ASX: BIM), Eastern Resources Ltd (ASX: EFE) and Great Northern Minerals (ASX: GNM) plus a Non-Executive Director of M3 Mining Ltd (ASX: M3M), Queensland Pacific Metals Ltd (ASX: QPM)



**Greg Columbus**  
Non-Executive Director

Over 30 years of experience in Energy, and Oil & Gas including technical, commercial, executive, and non-executive roles. During this time, he has gained valuable business experience in delivering large, complex energy and oil & gas projects and has throughout the course of his career, also demonstrated strong strategic vision in leadership roles. Has also been involved in numerous M&A activities, most recently as the Independent Non-executive Chairman of Warrego Energy.



**Kent Masters**  
Anchor Investor

A core early investor in Noble Helium, Kent is Chairman, CEO and President of Albermarle, one of the world’s largest lithium companies. As former Executive Director of Linde, the world’s largest industrial gas company by market share and revenue (capped at ~US\$160B), Kent held responsibility for the Americas, Africa, East Asia, South Pacific. And helium. He knows his industrial gases and has a network that stretches across the world and includes project developers and off-takers.

# Invest in the future of helium.

A ground-floor investment in the potential discovery and development of the world's largest **green helium** reserve.

01

Helium market is accelerating



02

World class helium assets



03

Proven helium system



04

Commercialisation in view



# Contact

T: + 61 (0)8 9481 0389  
E: [info@noblehelium.com.au](mailto:info@noblehelium.com.au)

**Registered Office**  
Noble Helium Limited  
Level 8, London House  
216 St. Georges Terrace  
Perth WA 6000



# Our primary green helium doesn't come from fossil fuels.

Surface gas sampling in and around the Noble's tenements indicate that helium trapped underground is "Primary Helium" (associated with nitrogen rather than hydrocarbon gas).

- 95% of the world's current helium supply is associated with fossil fuel energy production.
- Our helium liquefaction plant will be powered by 100% renewable hydro-electric power
- Critical materials such as green helium has sustainability credentials which are highly desirable.

## Primary and Green Helium

In Tanzania, Primary Helium is being released from basement with Nitrogen and being trapped as a mixed gas in layers of reservoir and seal rocks, just like a conventional natural (methane) gas field.

