

Battery selection confirms longer battery duration at lower capital cost, enhancing Project economics

Frontier Energy Limited (ASX: FHE; OTCQB: FRHYF) (Frontier or the Company) is pleased to provide an update on the battery procurement process for the Stage One development of its Waroona Renewable Energy Project (Project), which comprises a 120MW solar facility and integrated four-hour 80MW battery.

HIGHLIGHTS

- Final battery technology selection has resulted in a 12% increase in the battery duration to approximately 4.5 hours, compared to 4 hours in the Definitive Feasibility Study¹ (DFS)
- The improved battery duration will increase Project revenue compared to the DFS, as more energy can be sold during peak electricity price periods, whilst Reserve Capacity Payments (RCP) will also be higher than previously forecast
- Despite this significant improvement, the capital cost for the battery has fallen by approximately 5% compared to the DFS (DFS estimate – \$118.5 million)
 - Frontier has narrowed its selection of preferred battery partners to two, both Tier 1 rated manufacturers
- The Company's funding strategy continues to progress strongly with both debt financing and strategic partnering well advanced

CEO Adam Kiley commented: "The Company is in the fortunate position that the cost of the two largest capital items, solar panels and battery, have fallen significantly since the release of the DFS in February.

Battery prices have fallen due to a combination of factors, including falling raw materials prices, improvement in supply chain, and reportedly weaker than anticipated demand, resulting in an ample supply of batteries in the current market.

This unique situation is to Frontier's advantage, with improved battery capacity resulting in increased duration (approximately 4.5 hours compared to 4 hours in the DFS), increasing Project revenue while at the same time achieving a lower capital cost.

The Company continues to progress its funding strategy, with both debt financing and strategic partnering processes well advanced."

¹ See ASX announcement 29 February 2024

Final battery selection confirms longer battery duration at a lower capital cost, enhancing Project economics

As part of the Stage One development of the Project, Frontier concluded that the optimal strategy for Project development consists of a 120MW solar facility and an 80MW/320 MWh battery, i.e. the battery is capable of storing and discharging 80MW for 4 hours.

Frontier selected a DC coupled system, the lowest capex and most efficient way of integrating battery storage into new renewable energy installations such as the Waroona solar facility. In a DC coupled system, the battery is connected directly to the DC side of the renewable energy source, the solar panels. DC coupling eliminates the need for an additional inverter to convert DC to AC since the battery system operates directly with the DC electricity generated by the renewable source. See Image 1.

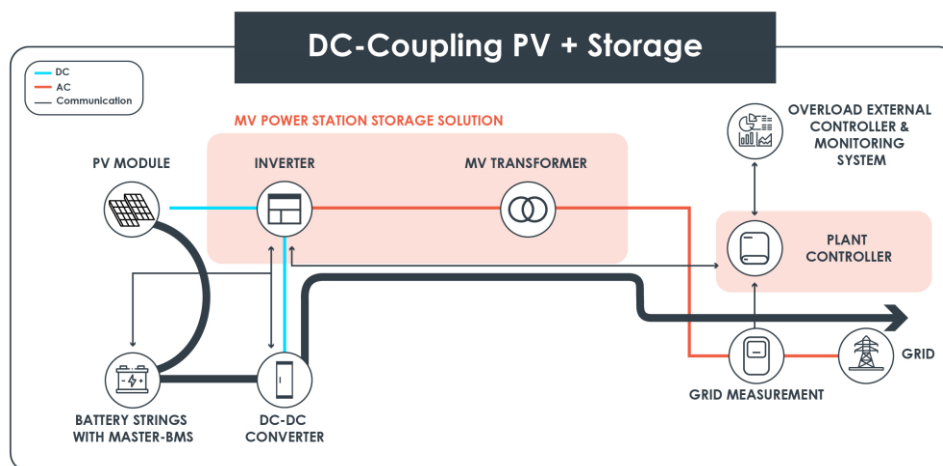

Image 1: DC Coupling PV plus storage

Lithium Iron (Fe) Phosphate (LFP) batteries have been selected for the Project as they are proven technology with superior safety, longer cycle life, higher energy density, faster charging capabilities, wider operating temperature range, and more favourable to the environment than other battery technologies.

Utility-scale LFP batteries experience capacity degradation over time due to factors like calendar aging, cycle aging, temperature, state of charge management, manufacturing quality, and usage patterns. These factors contribute to a gradual reduction in the battery's capacity and performance over its lifespan. The DFS assumed a degradation curve which was based on offers received at the time, that had a degradation of ~16% over the initial 10 years and ~26% over the first 20 years of battery life. See Image 2.

The Company's competitive tender process has delivered significant improvements compared to the DFS. Frontier has narrowed its selection of the preferred battery partners to two, both of which are rated as Tier 1 battery manufacturers.

Battery capacity has increased to approximately 4.5 hours, a rise of 12% compared to the DFS specifications of 4 hours. Despite this material capacity increase, the capital cost of the battery has reduced by approximately 5% from the original estimate of \$118.5m in the DFS. The improved MWh from the original DFS compared to the latest technology selected is highlighted in Image 2 below.

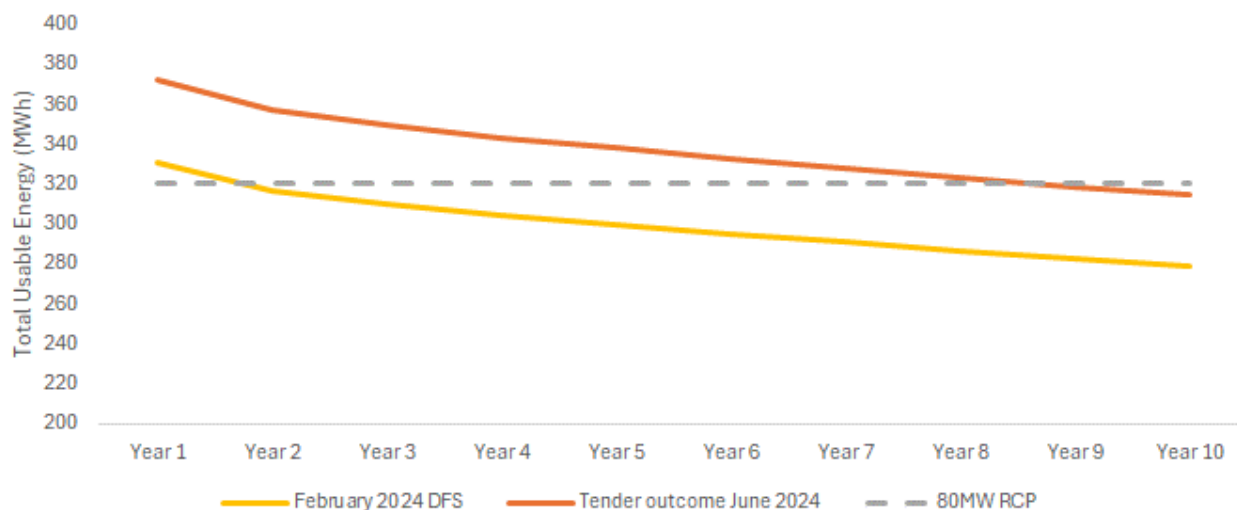

Image 2: Battery degradation curve

The improvements in the Project's battery technology effectively mean it can deliver more energy over time. This significantly enhances RCP revenue compared to the DFS, where the 4-hour power level dropped below 80MW (320 MW/h) from year 2 due to the natural degradation (Image 2).

The larger storage capacity also enables additional storage of electricity during times of low pricing (morning / lunch) and dispatch during times of peak pricing.

Authorised for release by Frontier Energy’s Board of Directors.

To learn more about the Company, please visit www.frontierhe.com, or contact:

Adam Kiley
CEO
 +61 8 9200 3428
akiley@frontierhe.com

Grant Davey
Executive Chair
 +61 8 9200 3428



About Frontier Energy

Frontier Energy Ltd (ASX: FHE; OTCQB: FRHYF) is developing the Waroona Renewable Energy Project located 120km south of Perth in Western Australia.

Waroona has the potential to become one of Western Australia's largest standalone renewable energy projects, as the Company controls 868ha of adjoining freehold land whilst also having approvals in place for a connection onto the WA electricity network (SWIS) with a terminal adjacent to the Project.

The Company released a positive DFS on a Stage One development that consists of a 120MW solar farm and 80MW 4-hour battery.

Frontier is fully committed to making the Project one of WA's major renewable energy hubs, incorporating multiple value-adding initiatives including batteries and green hydrogen, with full renewable energy potential of more than 1GW based on connection capacity.

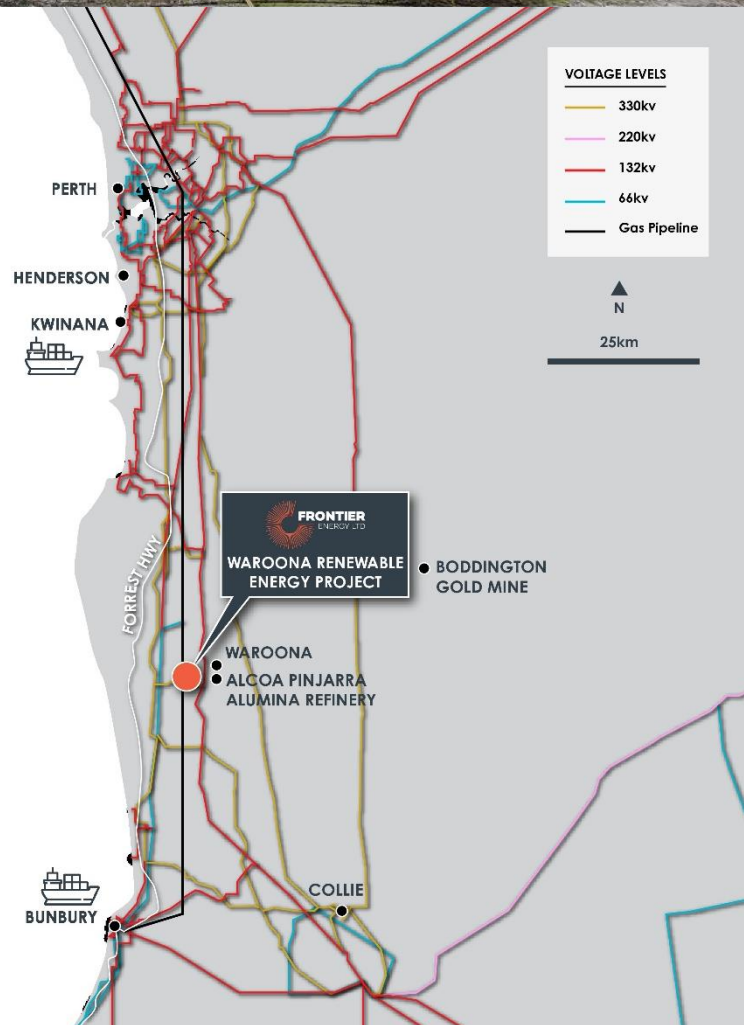

Directors and Management

Mr Grant Davey
Executive Chairman

Mr Adam Kiley
Chief Executive Officer

Mr Chris Bath
Executive Director

Ms Dixie Marshall
Non-Executive Director

Ms Amanda Reid
Non-Executive Director

Registered Office

Level 20, 140 St Georges Terrace
Perth WA 6000

Share Registry

Automatic Registry Services
Level 5, 126 Philip Street
Sydney NSW 2000

For a comprehensive view of information that has been lodged on the ASX online lodgement system and the Company website, please visit asx.com.au and frontierhe.com, respectively.