

## HAZER PILOT PLANT TESTING EXCEEDS CAPACITY TARGETS BY 300%

- **Testing has commenced on 2nd Generation Pre-Pilot Plant (herein referred to as “FBR Pilot Plant”).**
- **Nominal hydrogen and graphite production capacity targets exceeded by nearly 300%; with capacities of ~8 kg/d hydrogen and ~29 kg/d graphite achieved.**
- **A total of 40 kg of graphite and 10 kg of hydrogen has been produced from five initial test runs; with the largest haul from a single run being 12.4 kg of graphite.**
- **Testing now focussed now on optimisation of hydrogen and graphite purity.**

**PERTH, AUSTRALIA, 9th AUGUST 2018:** Hazer Group Ltd (“Hazer”) (ASX: HZR) has successfully upgraded and commissioned the 2nd Generation Pre-Pilot Plant with multiple test runs exceeding capacity targets by 300%. Due to this significant increase in capacity of this plant, it will now be referred to as the Fluid Bed Reactor Pilot Plant (“FBR Pilot Plant”).

Initial testing of the FBR Pilot Plant conducted over the past month focussed on validating operations of the new systems and increasing the average production capacity for both graphite and hydrogen product. Testing will continue but with the focus shifting to optimising the purity of the products in conjunction with a rigorous regime of extended continuous operation testing.

FBR Pilot Plant Testing stages completed and forward timelines

- |    |                                 |            |
|----|---------------------------------|------------|
| 1. | Increased system capacity       | ✓          |
| 2. | Increased product purity        | Q3 2018    |
| 3. | Increased run duration (>24hrs) | Q3/Q4 2018 |

“Since the 1st Generation Pre-Pilot Plant<sup>1</sup> results, we rapidly progressed the technical development of the Hazer process. In doing so, we have exceeded our expectations and now have a true Pilot Plant with a proven production capacity that is a relevant demonstration of Hazer’s reactor technology. Our focus is now shifting to the commercialisation phase where we will develop multiple strategies to generate revenue from this exciting new technology,” said Acting CEO Mark Edwards.

1. Refer to ASX Announcement “Pre Pilot Plant Performance Improvements and Upgrades update” released on 19 July 2018.

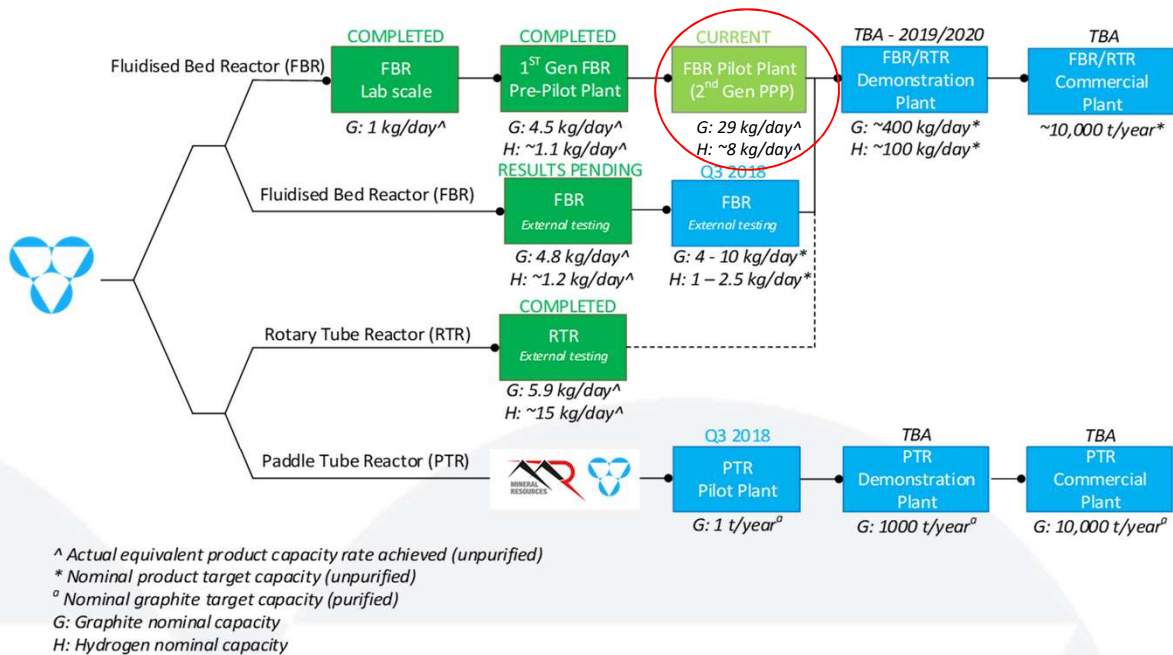

Figure 1: The Hazer Pilot Plant (circled in red) contributes to the overall development of a commercial pathway. Refer to ASX announcement “Corporate & Technical Development Update” released on 19th June 2018 for more details.

### SUCCESSFUL STAGE 1 TESTING RESULTS

Initial test runs on the FBR Pilot Plant have already achieved nominal average graphite production rates as high as ca. 29 kg/d of graphite and ca. 8 kg/d of hydrogen, representing an increase of over 650% of the maximum demonstrated production capacity of the 1st Gen PPP<sup>1</sup>, and nearly 300% of targeted capacities.

A total of 40 kg of graphite has been produced from five initial tests runs with the largest run producing 12.4 kg of graphite. This graphite will be used for downstream application and characterization evaluation.

The corresponding total hydrogen production from the five runs was 10 kg and the largest run produced 3 kilograms. This hydrogen is vented along with the reaction tail gas.

	Lab FBR* COMPLETED		1st Gen PPP COMPLETED		FBR Pilot Plant (2nd Gen PPP) ONGOING		Demonstration plant (TBA)	
	Target	Achieved	Target	Achieved	Target	Achieved	Target	Achieved
Graphite - Nominal capacity	1 kg/d	1.5 kg/d	1 kg/d	4.5 kg/d	10 kg/d	29 kg/d	400 kg/d	TBA
Graphite - Single run production	1 kg*	1 kg	1 kg	0.9 kg	10 kg	12.4 kg	TBA	TBA
Graphite - Maximum purity	75%	78%	85%wt	87%wt	90% wt	80% wt	TBA	TBA
Hydrogen - Nominal capacity	Not tested	Not tested	0.25 kg/d	~1.1 kg/d	2.5 kg/d	~8 kg/d	100 kg/d	TBA
Hydrogen - Maximum purity	Not tested	Not tested	50% vol	51% vol	60% vol	49% vol	TBA	TBA

\*Sub optimal reaction conditions and non-continuous operation

Table 1: Key performance results and targets for each FBR development stage.

---

“The next stage of testing on the FBR Pilot Plant will be to focus on the purities of the hydrogen and graphite products, even though they are already in commercial ranges, further optimisation will improve economics before they are post purified using conventional systems,” said Mr Edwards.

1. Refer to ASX Announcement “Pre Pilot Plant Performance Improvements and Upgrades update” released on 19 July 2018.

[ENDS]

#### **ABOUT HAZER GROUP LTD**

Hazer Group Limited (“Hazer” or “The Company”) is an ASX-listed technology development company undertaking the commercialisation of the Hazer Process, a low-emission hydrogen and graphite production process. The Hazer Process enables the effective conversion of natural gas and similar feedstocks, into hydrogen and high quality graphite, using iron ore as a process catalyst.

For further information, investor or media enquiries, please contact:

#### **Tom Murrell**

Email: [contact@hazergroup.com.au](mailto:contact@hazergroup.com.au)

Phone: +61 417 984 996

#### **Hazer Group Limited - Social Media Policy**

Hazer Group Limited is committed to communicating with the investment community through all available channels. Whilst ASX remains the prime channel for market sensitive news, investors and other interested parties are encouraged to follow Hazer on Twitter (@hazergroupltd), LinkedIn, Google+ and Youtube.

