

WESTERN AREAS LTD

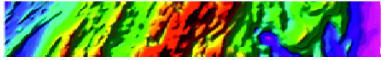

HALF YEAR RESULTS PRESENTATION

Half Year Ended 31 December 2014

FEBRUARY 2015



DISCLAIMER AND FORWARD LOOKING STATEMENTS

This presentation is being furnished to you solely for your information and for your use and may not be copied, reproduced or redistributed to any other person in any manner. You agree to keep the contents of this presentation and these materials confidential. The information contained in this presentation does not constitute or form any part of any offer or invitation to purchase any securities and neither the issue of the information nor anything contained herein shall form the basis of, or be relied upon in connection with, any contract or commitment on the part of any person to proceed with any transaction.

The distribution of this presentation in jurisdictions outside Australia may be restricted by law, and persons into whose possession this presentation comes should inform themselves about, and observe, any such restrictions. This is not for distribution or dissemination in the U.S.

The information contained in this presentation has been prepared by Western Areas Ltd. No representation or warranty, express or implied, is or will be made in or in relation to, and no responsibility or liability is or will be accepted by Western Areas Ltd, employees or representatives as to the accuracy or completeness of this information or any other written or oral information made available to any interested party or its advisers and any liability therefore is hereby expressly disclaimed. No party has any obligation to notify opinion changes or if it becomes aware of any inaccuracy in or omission from this presentation. All opinions and projections expressed in this presentation are given as of this date and are subject to change without notice.

This document contains forward-looking statements including nickel production targets and cost estimates. These statements are based on assumptions and contingencies that are subject to change without notice, and certain risks and uncertainties that could cause the performance or achievements of Western Areas Ltd to differ materially from the information set forth herein. Often, but not always, forward looking statements can generally be identified by the use of forward looking words such as “may”, “will”, “expect”, “intend”, “plan”, “estimate”, “anticipate”, “continue”, and “guidance”, or other similar words and may include, without limitation, statements regarding plans, strategies and objectives of management, anticipated production and expected costs. Western Areas Ltd undertakes no obligation to revise these forward-looking statements to reflect subsequent events or circumstances. Individuals should not place undue reliance on forward-looking statements and are advised to make their own independent analysis and determination with respect to the forecasted periods, which reflect Western Areas Ltd’s view only as of the date hereof.

The information within this PowerPoint presentation was compiled by Western Areas management, but the information as it relates to mineral resources and reserves was prepared by Mr. Dan Lougher and Mr. Andre Wulfse. Mr. Lougher and Mr. Wulfse are full time employees of Western Areas Ltd. Mr. Lougher and Mr. Wulfse are members of Australian Institute of Mining and Metallurgy (AusIMM) and have sufficient experience which is relevant to the style of mineralisation and type of deposit under consideration and to the activity which they are undertaking to qualify as Competent Persons as defined in the 2012 Edition of the ‘Australasian Code for Reporting of Exploration Results, Mineral Resources and Ore Reserves’(2012 JORC Code). Mr. Lougher and Mr. Wulfse consent to the inclusion in this presentation of the matters based on the information in the form and context in which it appears. The information contained in this presentation in relation to the New Morning Deposit was prepared and first disclosed under the 2004 Edition of the JORC Code. It has not been updated since to comply with the 2012 JORC Code on the basis that the information has not materially changed since it was last reported.

For the Purposes of Clause 3.4(e) in Canadian instrument 43-101, the Company warrants that Mineral Resources which are not Mineral Reserves do not have demonstrated economic viability.

AGENDA

- Full Year Financials and FY15 Guidance
- Operations
- Offtake & Nickel Market
- Corporate
- Exploration & Growth Outlook

Explore



Mine



Produce



Sales



WESTERN AREAS LTD

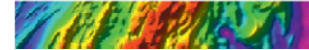

HALF YEAR FINANCIALS AND FY15 GUIDANCE UPDATE



KEY TAKEAWAYS – HALF YEAR

- **LTIFR of 1.00** – one of the lowest in the mining industry
- 13,257t nickel in ore production averaging 5.0% nickel grade
- Nickel in concentrate production of 12,945t
- A\$2.37/lb (US\$2.11/lb) cash cost in concentrate (guidance was A\$2.70/lb to A\$2.80/lb):
 - Remains best in class in Australia
 - Significant reduction over the previous half year of A\$2.56/lb
- Capital, Mine Development and Exploration Expenditure incurred A\$34.7m:
 - Well within full year guidance range of A\$70m to A\$80m
- Pre-Financing Cashflow of A\$52.9m
 - 20% increase of A\$8.5m versus 2HFY14, despite A\$1.08/lb decrease in the nickel price
 - 175% increase of A\$33.6m versus 1HFY14, with A\$1.14/lb increase in the nickel price
- Reported NPAT of A\$23.6m:
 - Realised nickel price reduction leading to negative QP of A\$17.0m before tax (+A\$22.2m in 2H15)
 - QP was adjusted for the January's nickel price movement, therefore go forward benchmark for QP is favorable based on forecasts
- Net cash increased A\$43.4m to A\$53.7m from 6 months ago
- Fully franked interim dividend of 3c (threefold increase on 1HFY14)

FINANCIAL SNAPSHOT

1st Half Highlights (\$'000)	1H FY 2014 (Jul -Dec 13)	2H FY 2014 (Jan -Jun 14)	1H FY 2015 (Jul -Dec 14)
Mine Production (tonnes Ni)	15,697	14,872	13,257
Mill Production (tonnes Ni)	13,020	12,596	12,945
Recovery	89%	89%	90%
Sales Volume (tonnes Ni)	12,963	12,793	12,894
Cash Costs (A\$/lb)	2.41	2.56	2.37
Realised Nickel Price (A\$/lb)	6.98	9.20	8.12
Nickel Revenue	143,374	176,704	164,938
EBITDA	65,411	92,804	74,862
EBIT	20,723	48,596	42,168
NPAT	2,671	22,789	23,553
Pre-Financing Cashflow	19,252	44,402	52,885
Net Cash	(135,300)	10,337	53,745
Dividend (cents)	1.0	4.0	3.0

Sales tonnages extremely consistent

Unit costs continue to reduce

Realised nickel price decreased A\$1.08/lb from 2HFY14

EBITDA impacted by lower nickel price and negative QP of A\$17.0m

Pre-financing cashflow increases with lower operational costs and interest expense and working capital timing

Improved cashflow allowed increased interim dividend

INCOME STATEMENT

Earnings Data (\$'000)	1H FY 2014	2H FY 2014	1H FY 2015
Realised Nickel Price (A\$/lb)	6.98	9.20	8.12
Nickel Revenue	143,374	176,704	164,938
EBITDA	65,411	92,804	74,862
Depreciation & Amortisation	(44,688)	(41,092)	(32,535)
Impairment	-	(3,116)	(159)
EBIT	20,723	48,596	42,168
Interest Expense	(13,431)	(13,161)	(7,863)
Tax	(3,025)	(9,284)	(10,039)
Underlying NPAT	4,267	26,151	24,266
FinnAust expenditure	(1,596)	(3,362)	(713)
NPAT	2,671	22,789	23,553
Dividend (cents)	1.0	4.0	3.0
Earnings per share (cents)	1.6	10.6	10.1

Commentary (1H15 v 1H14)

- Nickel price up A\$1.12/lb in 1H15 on weaker AUD and stronger US nickel price
- D&A down due to less ore tonnes extracted at higher than reserve grade
- Interest expense down due to debt repayment on 2 July 2014
- Reported NPAT up 782% due to improved nickel price and lower costs, partially offset by increased taxation

Commentary (1H15 v 2H14)

- Ni price down A\$1.08/lb which flowed through with negative QP of A\$17.0m vs positive QP of A\$22.2m in 2H14
- D&A down due to less ore tonnes extracted at higher than reserve grade
- Interest expense reduced through debt repayment of A\$95.2m
- Carbon credit income down A\$5m, however new power contract under negotiation
- Royalty payments increased (\$3.0m) at Flying Fox with increased tonnes from Lounge Lizard

INCOME STATEMENT WATERFALLS

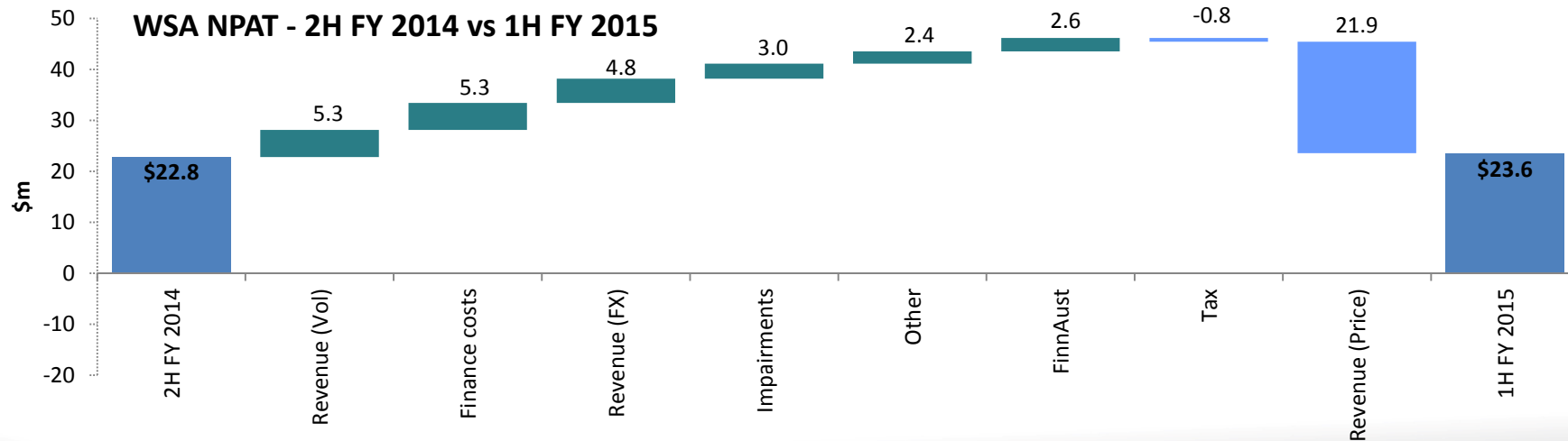
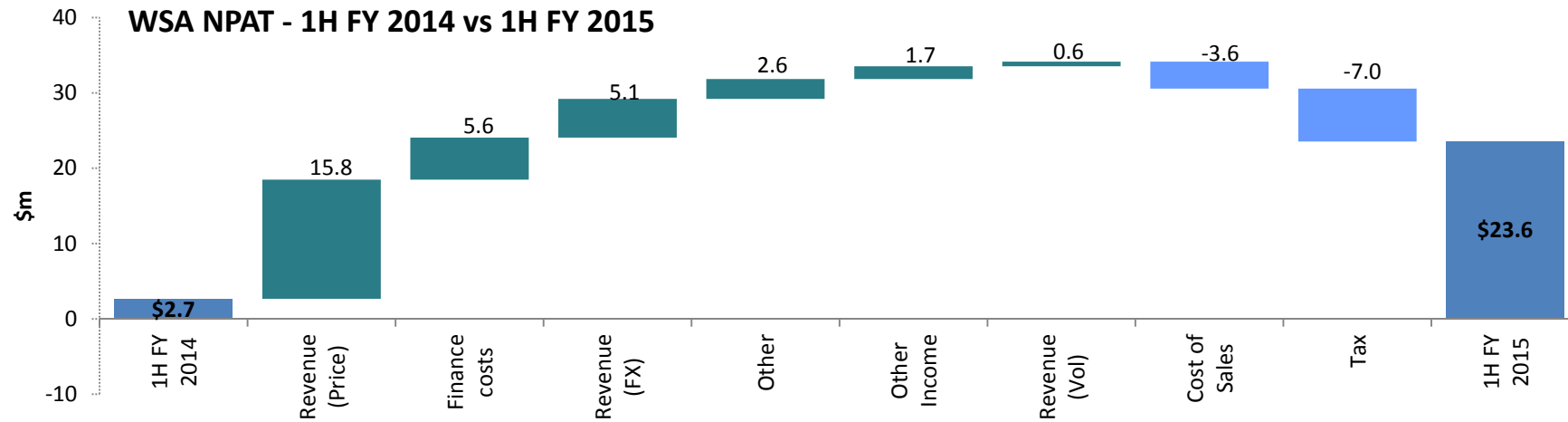

CASHFLOW STATEMENT

Cashflow Statement (\$'000)	1H FY 2014	2H FY 2014	1H FY 2015
Operating Cashflow	49,201	67,829	87,583
<i>Less:</i>			
Exploration	(9,976)	(7,059)	(8,529)
FinnAust Investment	(2,370)	-	-
Mine Development	(15,629)	(13,809)	(22,431)
Capital Expenditure	(1,974)	(2,559)	(3,738)
Pre-Financing Cashflow	19,252	44,402	52,885
Investment activities	-	(406)	(50)
Proceeds from Share Issues	-	106,342	-
Proceeds/(Costs) from Financing	(71)	(2,378)	(126)
Dividends Paid	-	(2,323)	(9,303)
Repayment of convertible bond	-	(15,000)	(95,198)
Net Cashflow	19,181	130,637	(51,792)
Cash at Bank	99,900	230,537	178,745

Commentary (1H15 v 1H14)

- Operating cashflow A\$38.4m higher due to the realised nickel price up A\$1.07/lb and improvement in working capital
- Higher mine development with Spotted Quoll North brought into production
- Convertible bond repaid on 2 July 14 for A\$95.2m which has led to a reduction in interest costs
- Final 4c fully franked dividend paid

Commentary (1H15 v 2H14)

- Operating cashflow higher despite a lower nickel price with improved working capital movement (lower debtors) and lower payments to suppliers
- Higher dividend in 1H15 and debt repayments were offset by an equity raise in Feb 14

CASHFLOW STATEMENT WATERFALL

WSA Cashflow - 1H FY 2014 vs 1H FY 2015

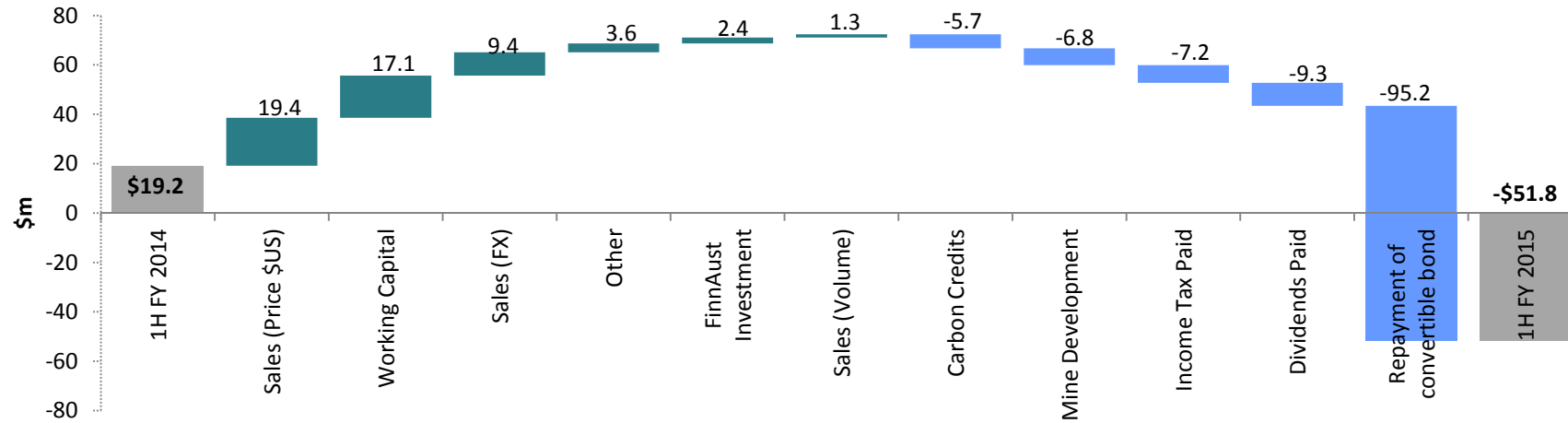

WSA Cashflow - 2H FY 2014 vs 1H FY 2015

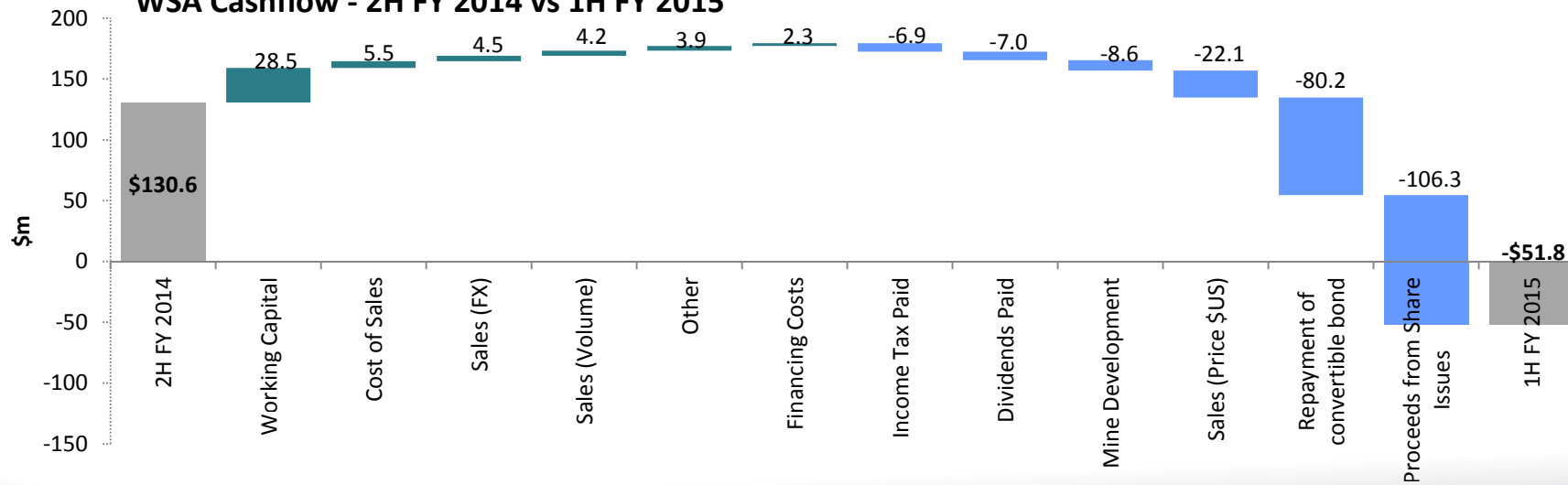

BALANCE SHEET

Balance Sheet	1H FY 2014	2H FY 2014	1H FY 2015
Cash at Bank	99,900	230,537	178,745
Receivables	19,240	31,261	14,813
Stockpiles & Inventory	40,376	39,207	29,916
PP&E	106,314	102,290	98,298
Exploration & Evaluation	43,259	47,008	54,238
Mine Development	225,559	206,434	205,202
Other	2,211	1,798	1,424
TOTAL ASSETS	536,859	658,535	582,636
Trade & Other Payables	33,526	31,318	28,794
Short Term Borrowings	112,380	107,886	134,003
Long Term Borrowings	138,267	141,575	26,093
TOTAL LIABILITES	284,173	280,779	188,890
SHAREHOLDERS EQUITY	252,686	377,756	393,746

Commentary

- Net Cash of A\$53.7m at 1H15 versus net debt of A\$135.3m at 1H14, when allowing for the full face value of convertible bonds (CB) (A\$125.0m)
- Capital Management strategy has worked:
 - A\$15.0m and A\$95.2m CB repaid in CY14
 - A\$125.0m CB to be repaid on 2 July 15 from cash
 - A\$125.0m finance facility from ANZ fully undrawn
 - CB interest and cost savings around A\$12m in FY15 and combined A\$24m from July 15
- Receivables at 1H15 lower due to timing of payments
- Flexible balance sheet able to fund growth

UPDATED FY15 GUIDANCE

Target	Original Guidance	Recommended Guidance
Mine Production (Nickel in Ore)	25,000 to 27,000 tonnes	Mid-range of guidance
Nickel in Concentrate Production	24,500 to 25,500 tonnes	Upper end of guidance
Unit Cash Cost of Production (Nickel in Concentrate)	A\$2.70/lb to A\$2.80/lb	A\$2.40/lb to A\$2.50/lb
Capital Expenditure & Mine Development	A\$50m to A\$60m	No change
Exploration	A\$20m	No change

Comments

- ✓ Nickel in concentrate production tracking to upper end of guidance
- ✓ Unit costs guidance improved by A\$0.30/lb (approx A\$18m):
 - ✓ Reductions in all major operating contracts
 - ✓ Productivity improvements
 - ✓ Positive reconciliation to reserve, particularly at Flying Fox

WESTERN AREAS LTD



NICKEL MARKET



NICKEL PRICE MOVEMENTS

24 Month Nickel Price

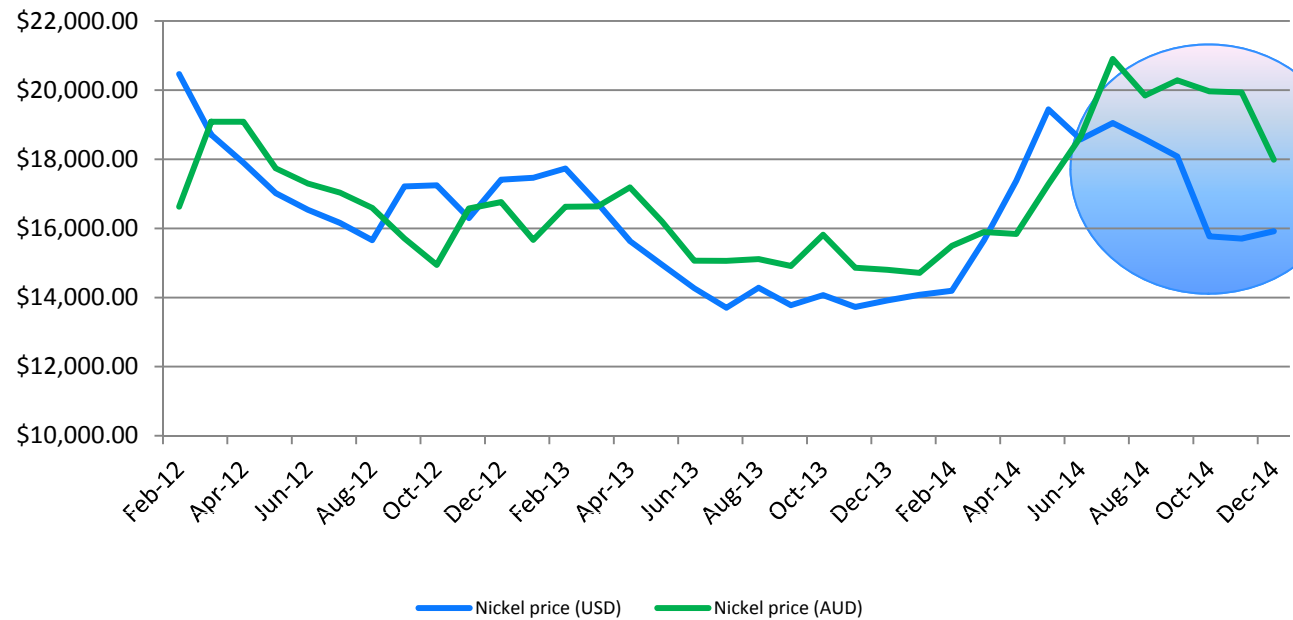

1H15 fall is USD nickel,
 partially offset by
 decreasing AUD

NICKEL PRICE DRIVERS

There are a number of factors that influence the nickel price including:

1. Level of global nickel supply
2. Cost and capacity of Chinese nickel pig iron (“NPI”) production
3. Indonesian nickel laterite export ban / Philippine response
4. Global stainless steel demand
5. Shorter term political factors



What we believe is occurring:

- Chinese ore stocks may run out mid-year with ore stocks on the decline
- Monsoon season now starting to bite Philippine exports
- NPI producer stockpiles greater than anticipated and ore blending has extended life
- LME stocks have continued to rise due to Chinese hidden stocks
- Stainless steel demand on balance remains strong in China

The fundamental market conditions and forecasts point to a nickel price rally late Q2 in CY15

CHINESE ORE STOCKPILES

Chinese Nickel Ore Stocks Total (Mt)

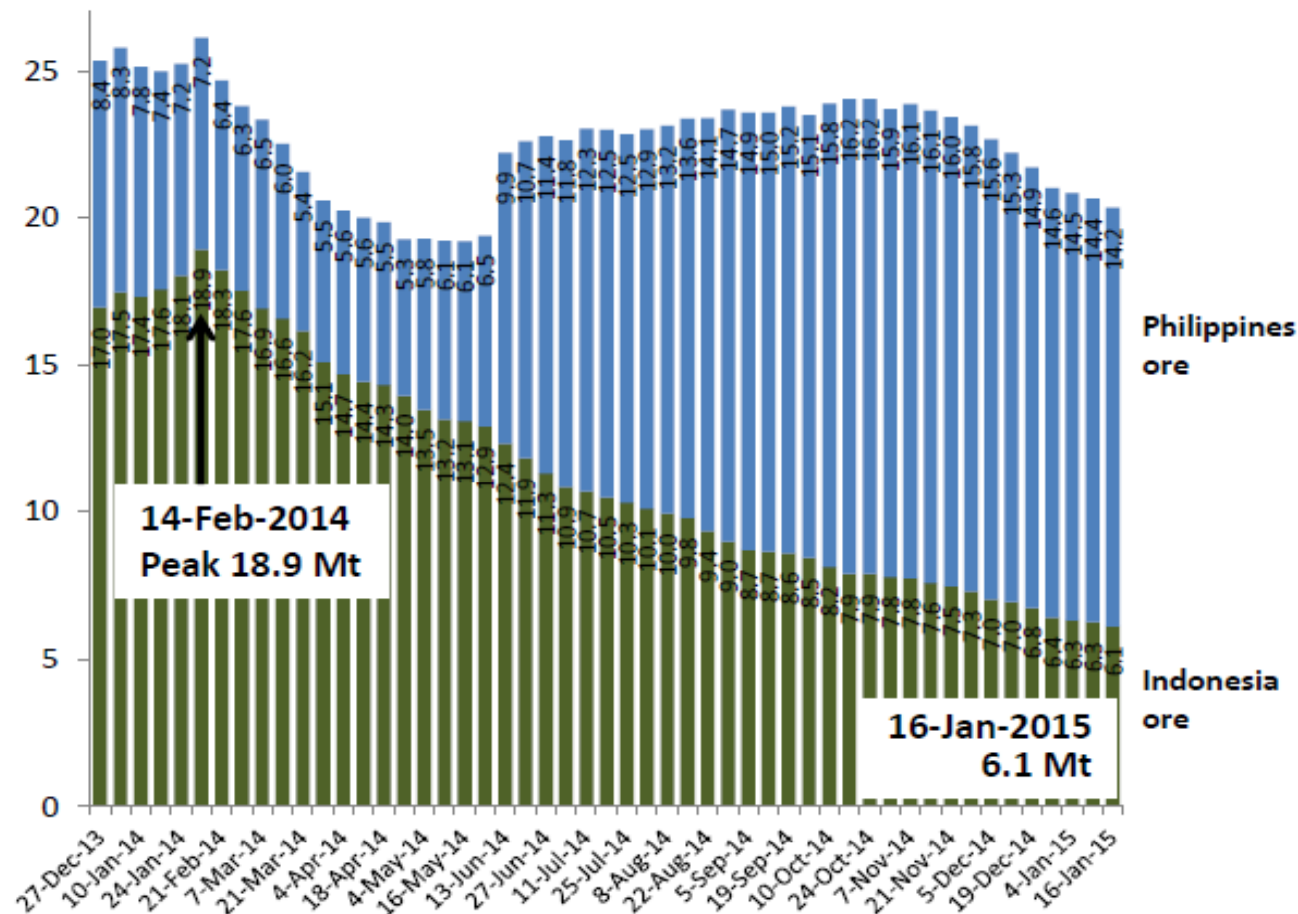

Source: Royal Nickel

NICKEL MARKET DYNAMICS

- Indonesia in a unique position in respect of high Ni grade, low Fe product
- Very strong message from the Indonesian government that **the ban is permanent**
- Reduction in Chinese NPI and Ferronickel from Japan of approximately 300ktpa contained nickel
- Approvals for Indonesian based NPI take a minimum of 18 months, plus construction, power supply and skilled labour issues mean that any meaningful production in at least 5 years away
- Nickel market deficits set to start in CY15, assuming 4% nickel demand growth and the Indonesian ban holding

World Saprolite Resources (Mt Ni contained)

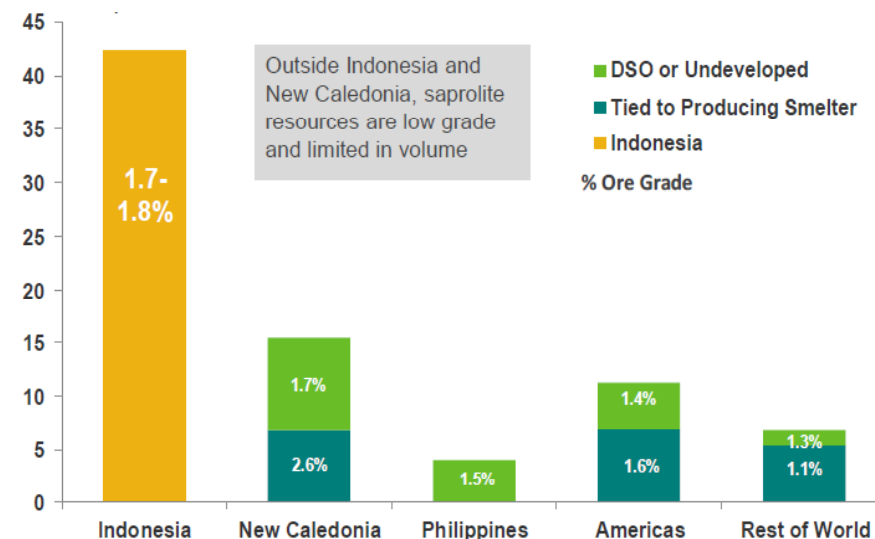

WESTERN AREAS LTD

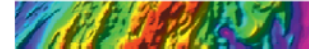

OPERATIONS



LOCATION, LOCATION, LOCATION.....

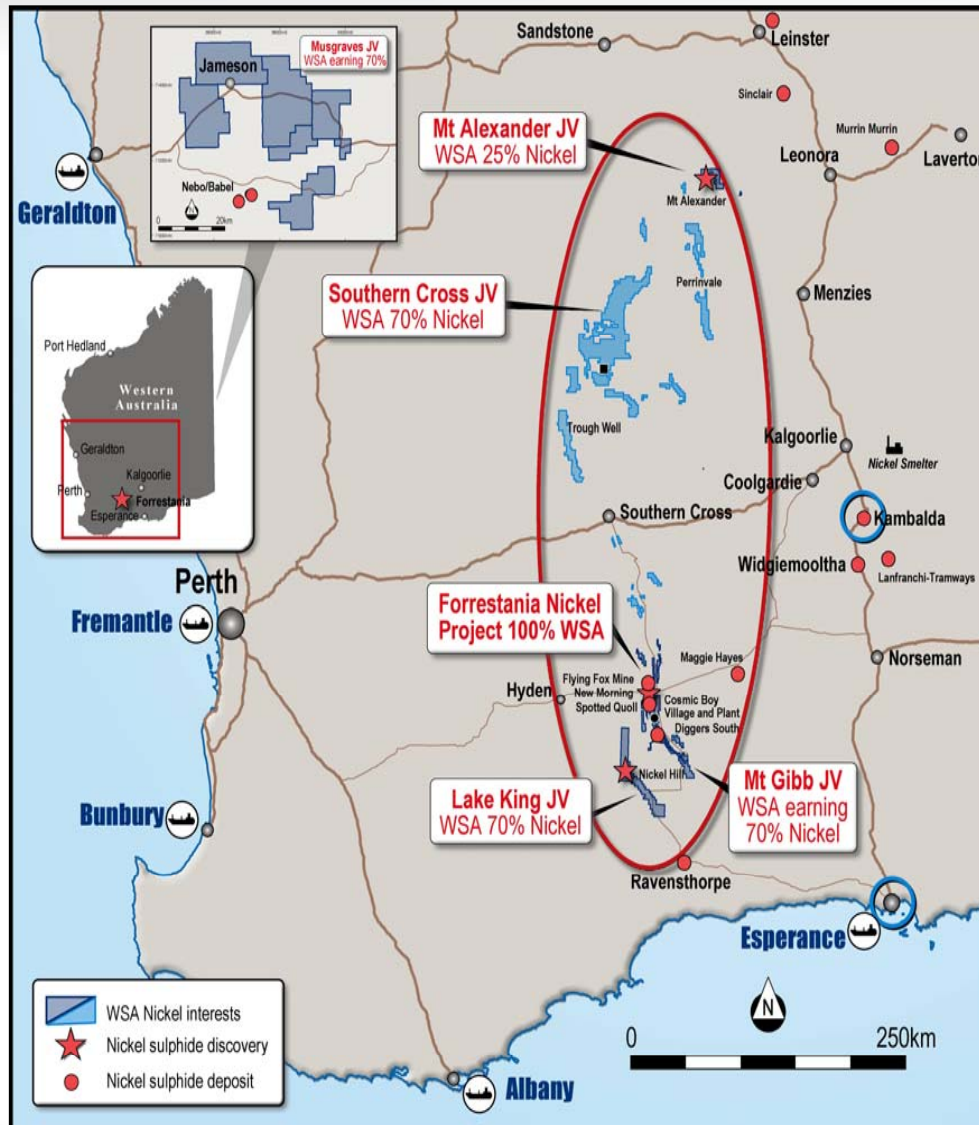

Some Facts

- FIFO & DIDO mine site – no near town infrastructure like Kalgoorlie, Kambalda and Port Hedland
- 55 minute flight to Forrestania
- Once you arrive at site:
 - 5 minutes from camp
 - 5 minutes from mill
 - 20 minutes from mines
- Use of local and WA based contractors
- 500 bed camp with excellent recreation facilities and IT infrastructure
- Extremely low headcount turnover due to culture, quality of mines, quality of camp and flat management structure
- Half-way between sale points at Kambalda and the Esperance Port

WESTERN AREAS ARE SAFE AREAS

Continuous Safety Improvement

- LTIFR 1.00
- Flying Fox >535 days LTI free
- Spotted Quoll >1,350 days LTI free
- Exploration >2,370 days LTI free
- Cosmic Boy Concentrator >550 days LTI free
- Contractors and employees fully integrated into a site wide commitment

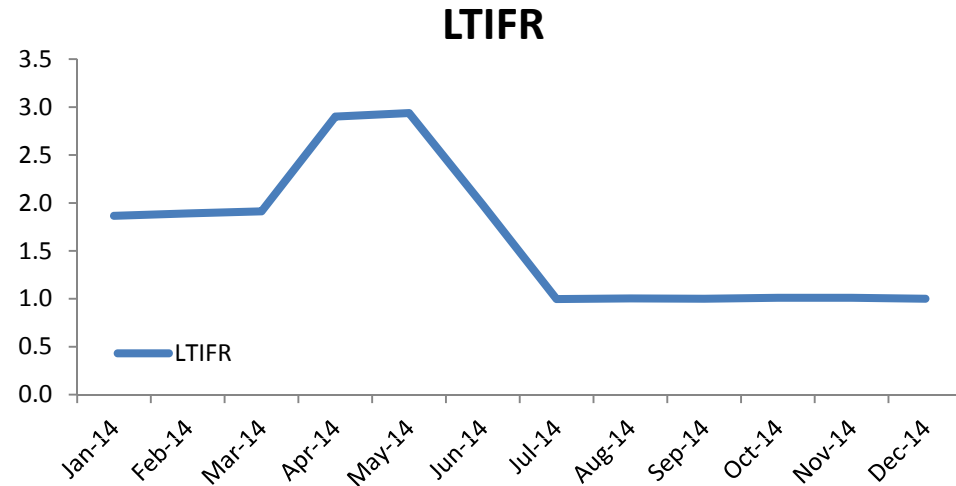

Environment & Social

- No environmental breaches
- Strong local commitments to schools and associations around Forrestania, Perth Zoo (Western Quoll) and Starlight Children's Foundation WA



OPERATING HIGH GRADE MINES



Lounge Lizard 10m wide face of 7% Massive Nickel Sulphide

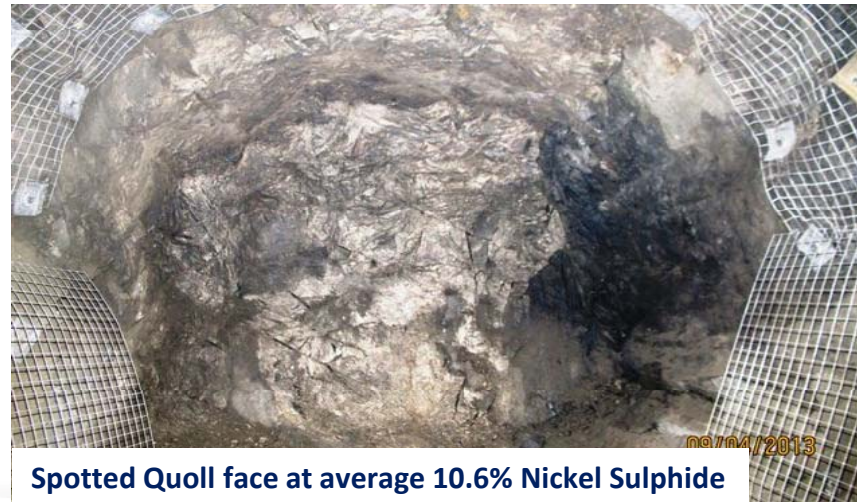

Spotted Quoll face at average 10.6% Nickel Sulphide

FLYING FOX MINE

Mineral Resource and Ore Reserve

- Reserve upgrade announced:
 - Added 7,572t nickel grading 6.5%
- High Grade (excluding disseminated sulphide resource) **Mineral Resource: 1.72Mt @ 5.2%** Ni containing 89,328 Ni Tonnes
- **Ore Reserve: 1.44Mt @ 4.1%** Ni containing 58,533 Ni Tonnes
- Underground drilling program to extend Mineral Resource remains a focus
- 1HFY15 – 129,219t @ 5.0% Ni for 6,498t Ni
- Recent exploration highlights in T5 and T6 include:
 - T5 – 3.3m @ 9.5% nickel
 - T6 – 3.5m @ 5.6% nickel

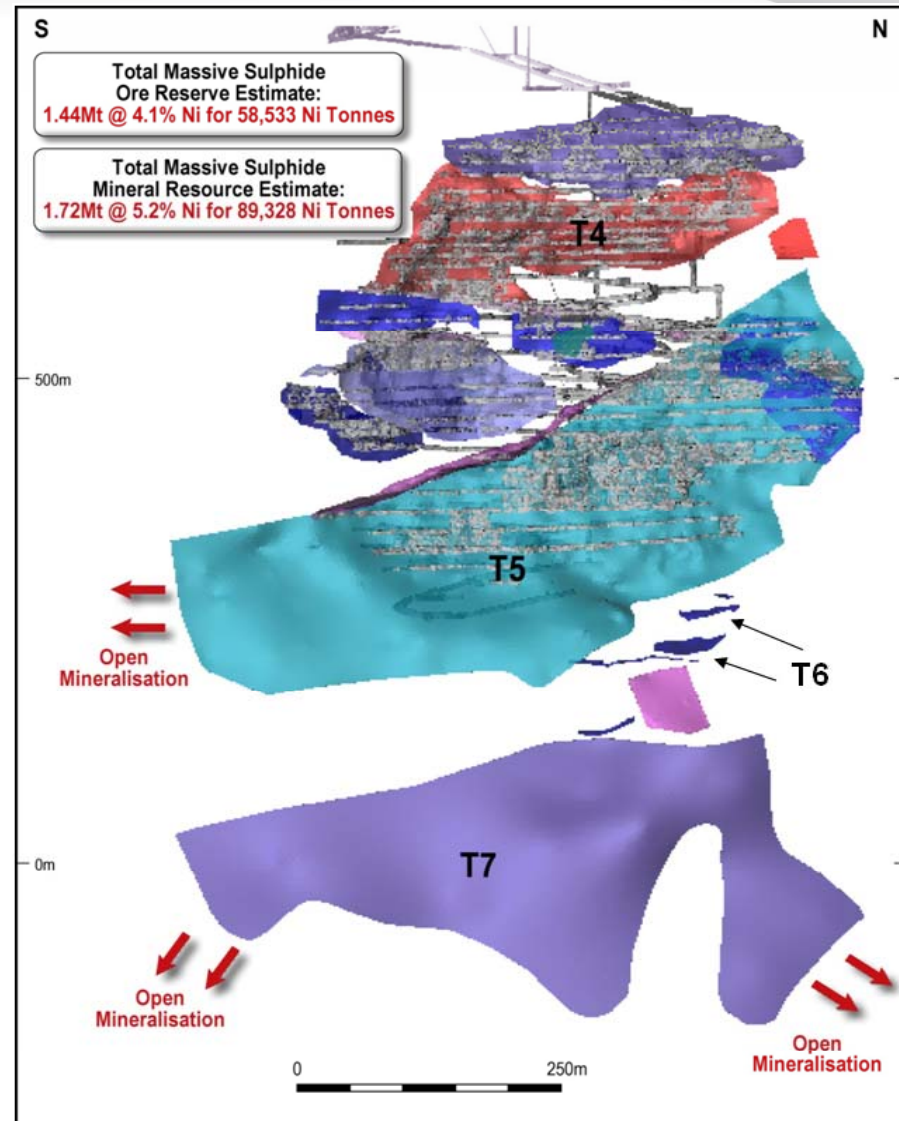

SPOTTED QUOLL MINE

Mineral Resource and Ore Reserve

- **Mineral Resource: 3.11Mt @ 5.5% Ni** containing 169,654 Ni tonnes
- **Ore Reserve: 2.86Mt @ 4.1% Ni** containing 116,222 Ni tonnes
- Remains open at depth and to the North
- Already around a 10 year mine life on Reserve

Production

- 1HFY15 – 136,770t @ 4.9% Ni for 6,759t Ni
- Top-down mining using paste fill

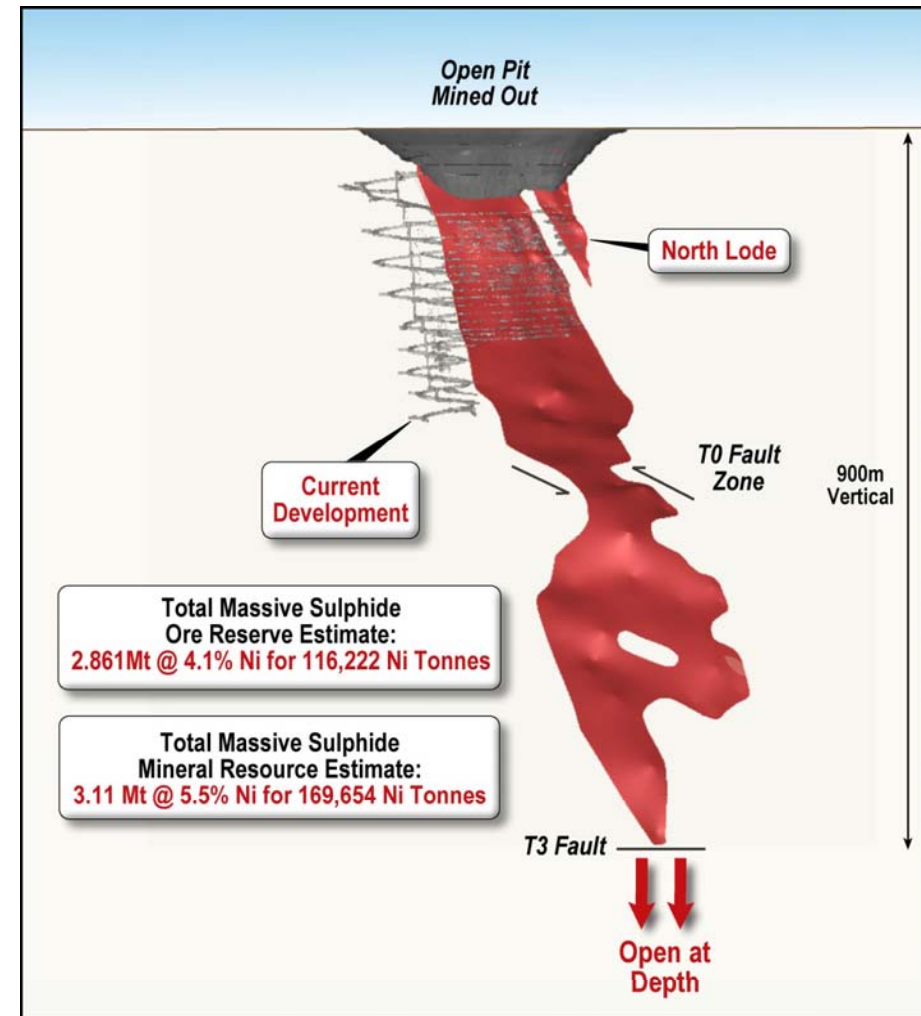

FORRESTANIA NICKEL CONCENTRATOR

Concentrator Summary

- Current nameplate capacity of 550,000tpa of ore but is achieving throughput 9% above capacity
- Nickel concentrate output circa 25,000tpa Ni
- Concentrate grades of around 14.0% Ni
 - Premium blending product (Fe/Mg ratio >15:1)
 - Desirable to smelters
- 14,000t of concentrate storage capacity

Export Infrastructure and Logistics

- Access to >1400 sealed shipping containers
- No environmental issues
- Using 25 trucks for concentrate transportation
- Shipping contract in place, FOB Esperance Port

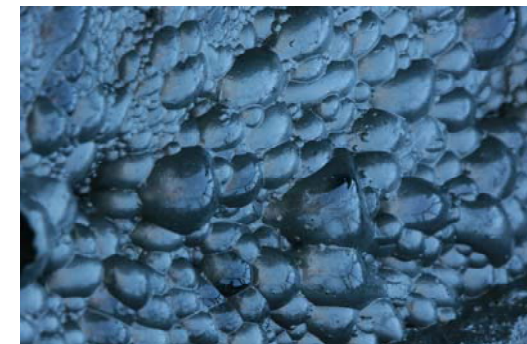

MILL RECOVERY ENHANCEMENT PROJECT

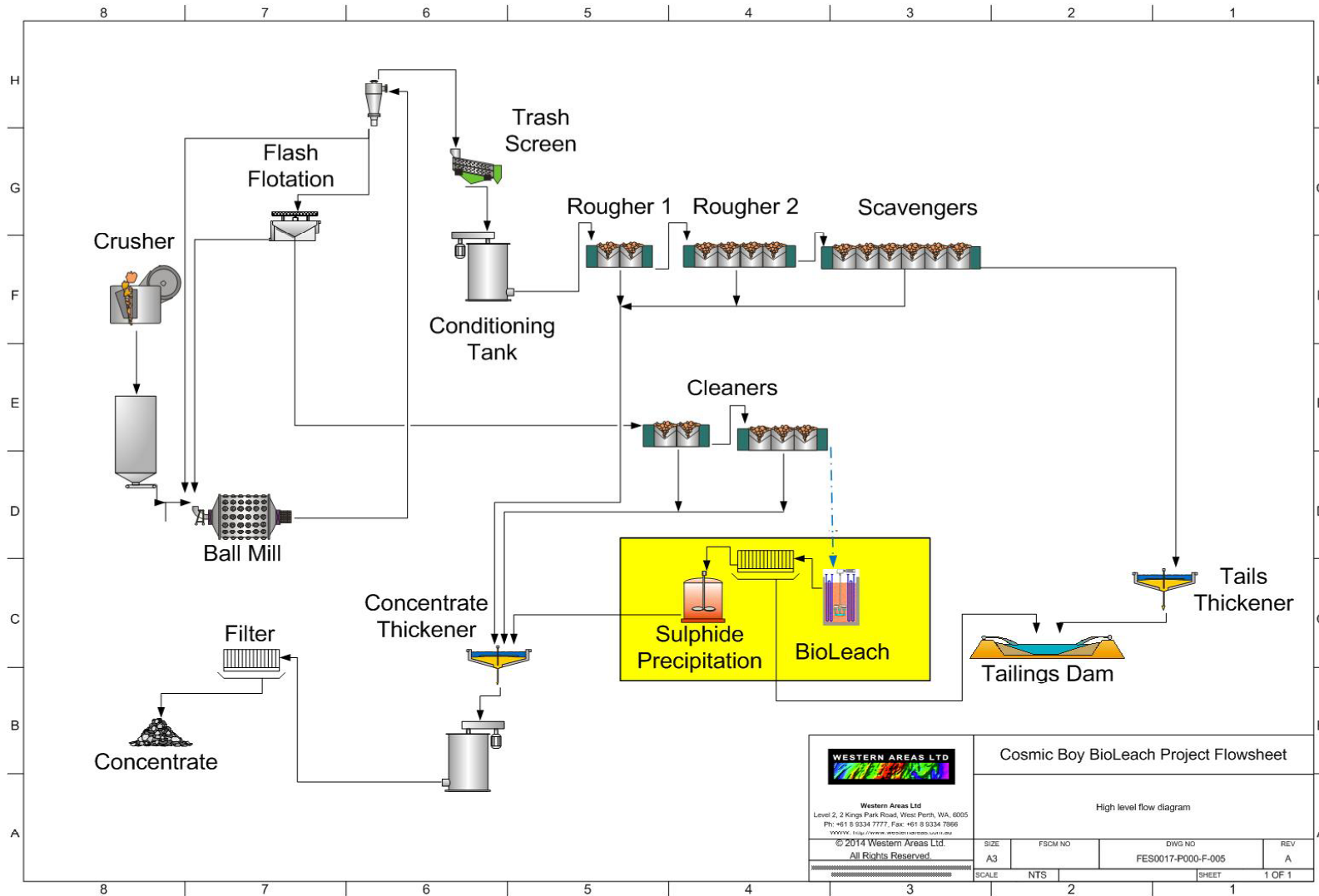

MILL RECOVERY ENHANCEMENT PROJECT

- Currently progressing through feasibility study
- Increase average nickel recoveries from 89% up to 93%
- Approximately 6 month construction time
- Early indicative capex of around A\$20m
- Quick payback and potentially operational early FY16
- The treatment of the Flash Cleaner Stream utilises the BioHeap® cultures on a continuous basis produced from a Bacterial farm
- Very short residence time of 5-7 days
- Operation at elevated pH eliminates the need for iron and arsenic precipitation circuits. Hence reduced CAPEX
- Sulphide precipitation circuit produces a high grade nickel sulphide product (~50% nickel)



INDEPENDENT PRODUCER – OFFTAKE CONTRACTS

Offtake Contracts

- FOB Terms
- Very competitive payable percentage of LME

Offtake Tender Announced

- Recently awarded Jinchuan a two year contract (26,000t of contained nickel)
- Tightness in smelter supply being experienced
- Global nickel sulphide grades in decline

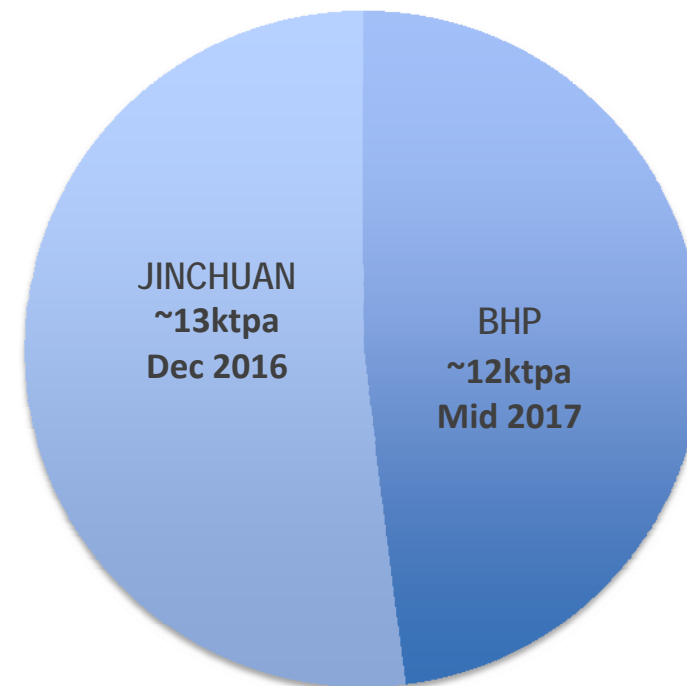

DECEMBER QUARTERLY REPORT

Tonnes Mined		2013/2014		2014/2015		YTD
		Mar Qtr	Jun Qtr	Sep Qtr	Dec Qtr	Total
Flying Fox						
Ore Tonnes Mined	Tns	79,328	67,966	65,097	64,122	129,219
Grade	Ni %	4.1%	5.1%	5.2%	4.9%	5.0%
Ni Tonnes Mined	Tns	3,243	3,479	3,384	3,114	6,498
Spotted Quoll - Underground						
Ore Tonnes Mined	Tns	71,614	58,497	68,446	68,324	136,770
Grade	Ni %	4.8%	4.8%	4.8%	5.1%	4.9%
Ni Tonnes Mined	Tns	3,466	2,801	3,276	3,483	6,759
Total - Ore Tonnes Mined	Tns	150,942	126,463	133,543	132,446	265,989
Grade	Ni %	4.4%	5.0%	5.0%	5.0%	5.0%
Total Ni Tonnes Mined	Tns	6,709	6,280	6,660	6,597	13,257
Tonnes Milled and Sold		Mar Qtr	Jun Qtr	Sep Qtr	Dec Qtr	Total
Ore Processed	Tns	147,544	151,232	153,474	152,407	305,881
Grade	%	4.8%	4.7%	4.7%	4.7%	4.7%
Ave. Recovery	%	90%	89%	90%	90%	90%
Ni Tonnes in Concentrate	Tns	6,344	6,336	6,511	6,434	12,945
Ni Tonnes in Concentrate Sold	Tns	6,418	6,374	6,648	6,246	12,894
Total Nickel Sold	Tns	6,418	6,374	6,648	6,246	12,894
Financial Statistics		2013/2014		2014/2015		DEC
		Mar Qtr	Jun Qtr	Sep Qtr	Dec Qtr	YTD
Group Production Cost/lb						
Mining Cost	A\$/lb	1.84	1.99	1.82	1.55	1.68
Haulage	A\$/lb	0.06	0.05	0.06	0.06	0.06
Milling	A\$/lb	0.43	0.43	0.44	0.43	0.44
Admin	A\$/lb	0.21	0.16	0.20	0.21	0.21
By Product Credits	A\$/lb	(0.02)	(0.02)	(0.02)	(0.02)	(0.02)
Cash Cost Ni in Con	A\$/lb	2.52	2.61	2.50	2.23	2.37
Cash Cost Ni in Con/lb	US\$/lb	2.26	2.43	2.31	1.91	2.11
Exchange Rate US\$ / A\$		0.90	0.93	0.93	0.86	0.89

Some Facts

- **Best cost performance in three years at A\$2.23/lb (US\$1.91/lb) in Q2 and materially below guidance**
- Grades and waste dilution management lead to strong reserve reconciliation – particularly at Flying Fox
- Remarkable consistency of production and other physicals
- Mill continues to beat nameplate by 10%

WESTERN AREAS LTD



EXPLORATION AND GROWTH OUTLOOK



FORRESTANIA TENEMENTS

Regional Geology

- 120km strike length (600 sq km) of prospective Forrestania Nickel Project, within 400km long nickel province
- Six ultramafic belts
- Nickel sulphide deposits and most occurrences in two belts (Eastern and Western)
- Western Ultramafic Belt hosts the high grade Flying Fox, Spotted Quoll and New Morning deposits

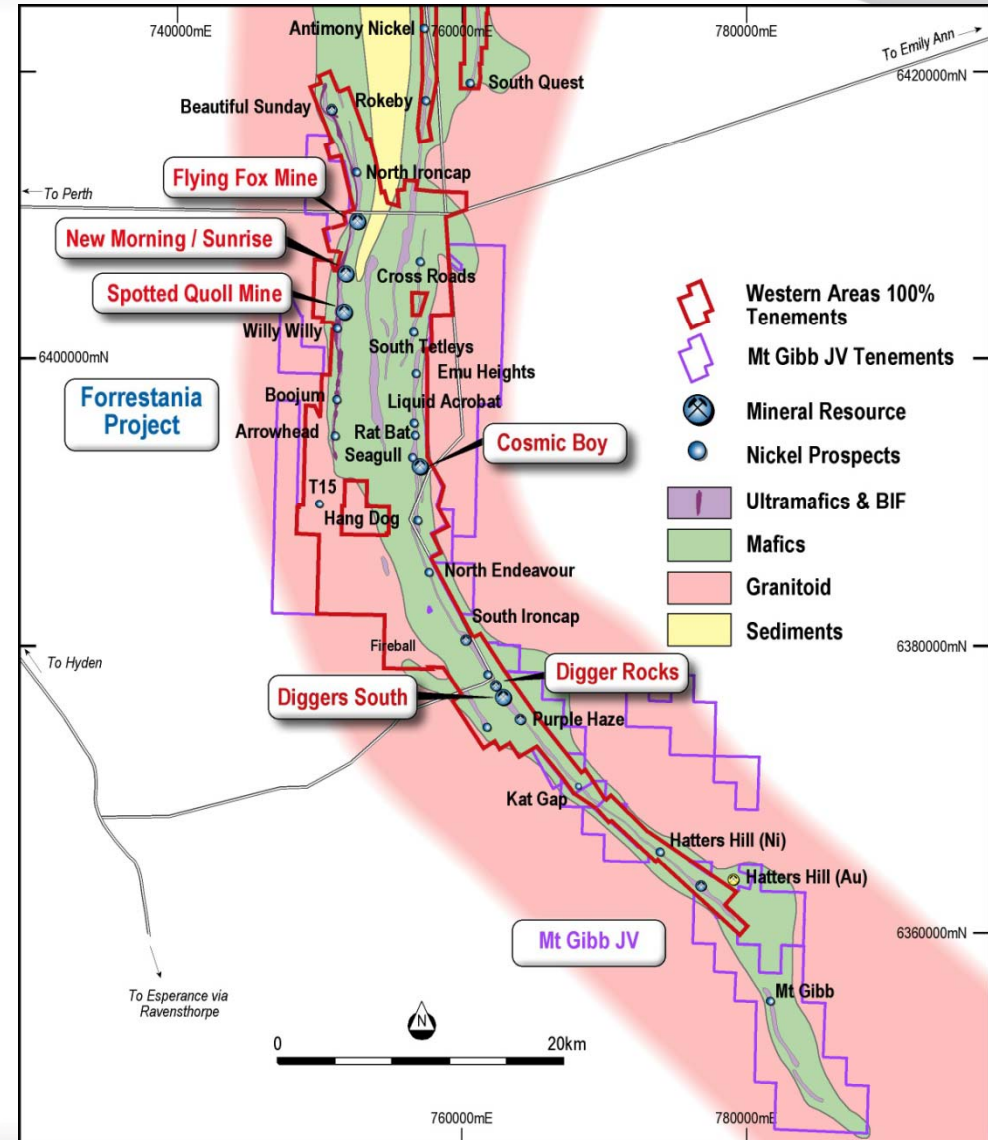

SHORT TERM – NEAR MINE EXPLORATION

- Exploration spend in FY15 likely >\$20m
- Drilling priority within 8km long zone (below). New discovery would access existing mine infrastructure. Systematic approach

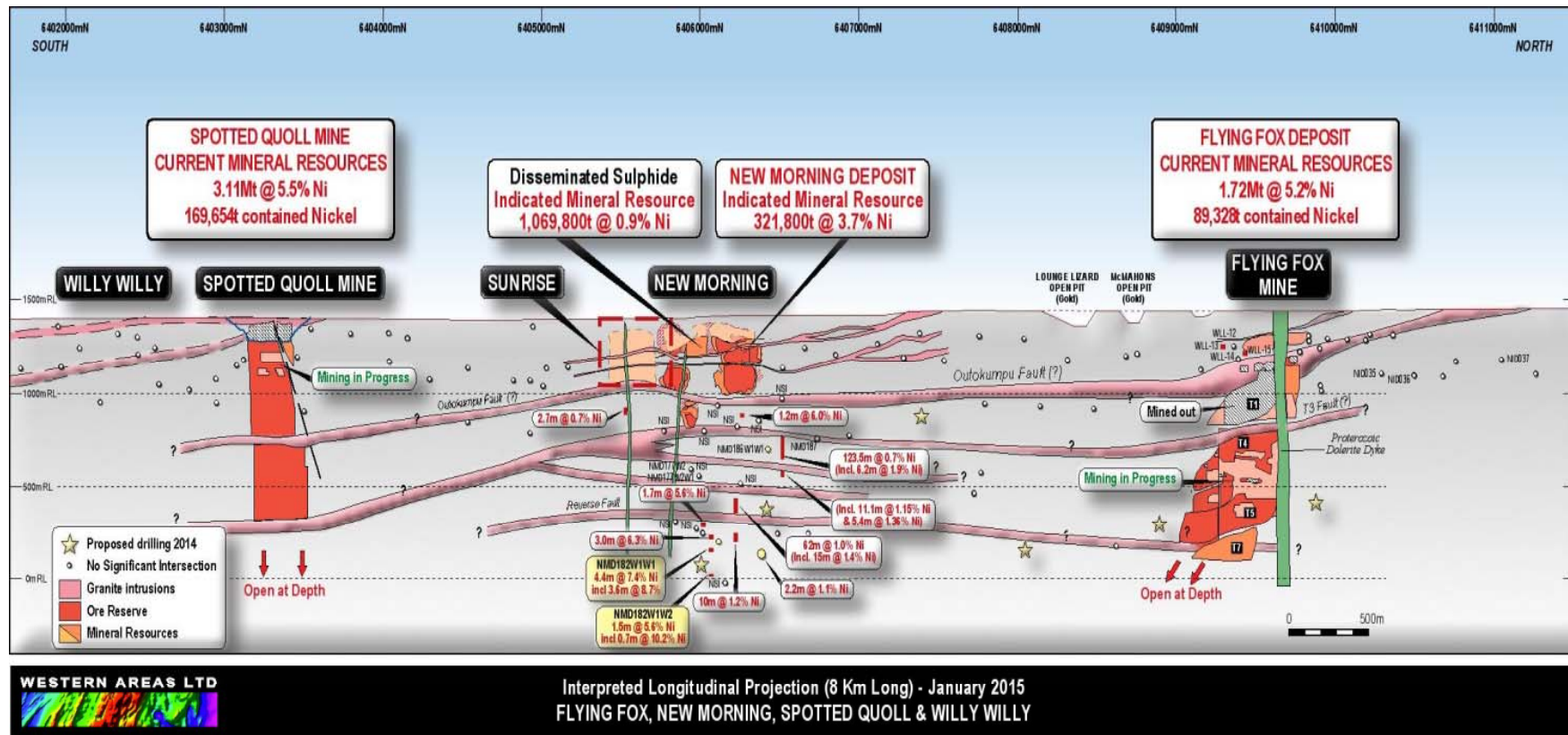

NEW MORNING

- 2.5km from Flying Fox and 2.8km from Spotted Quoll
- All material approvals in place, potential major capex savings & accessible from either mine
- Open Pit and shallow underground studies commenced
- Massive sulphide Indicated Resource of 321.8kt @ 3.7% nickel
- Significant intersections:
 - 4.4m @ 7.4% nickel including 3.6m @ 8.7% nickel
 - 3.0m @ 6.3% nickel including 2.4m @ 7.6% nickel
 - 1.5m @ 5.6% nickel including 0.7m @ 10.2% nickel
- Recent shallow hit of 54m @ 1.7% nickel from 38m (including 2.5m @ 5.0% nickel)

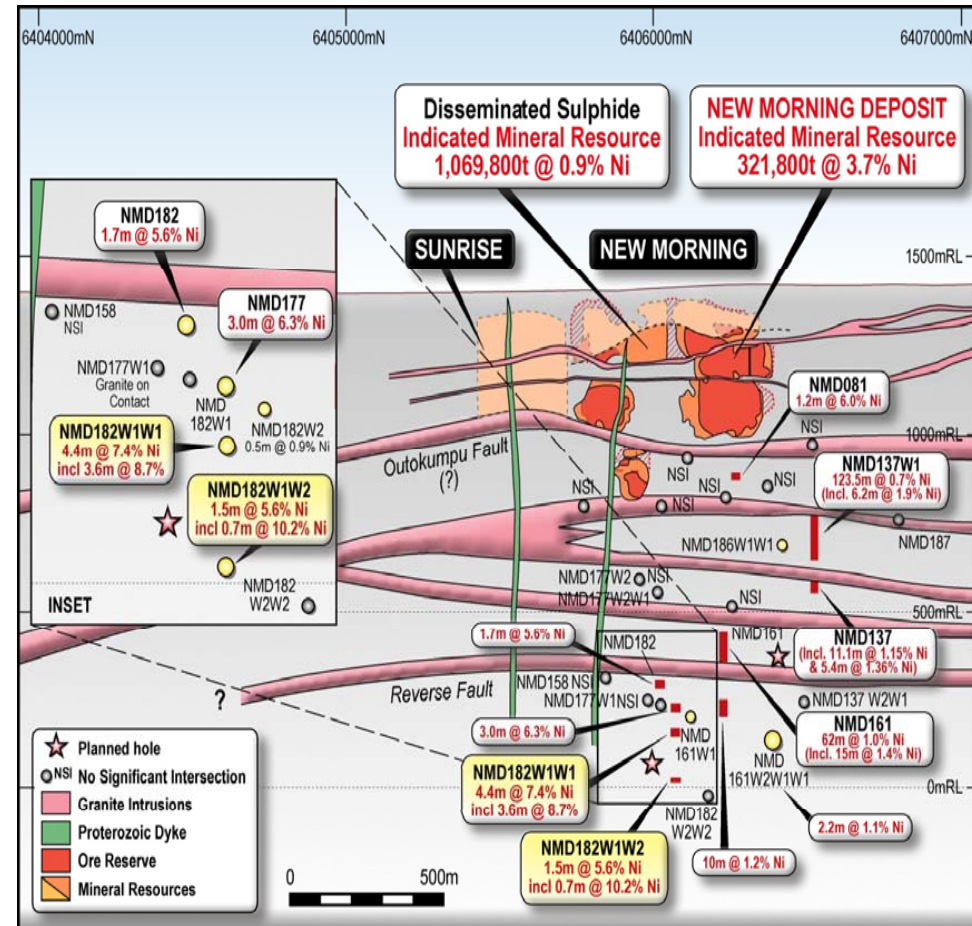

WESTERN GAWLER JOINT VENTURES

- Part of regional exploration strategy
- Two separate Farm-In Agreements with Gunson Resources Ltd and Monax Mining Ltd:
 - A\$0.8m on each to earn 75% over 2 years
 - Further A\$0.4m on each for 90% over additional 18 months
 - Close to existing infrastructure
 - Total area 2,746km²
- First mover advantages targeting massive high grade poly-metallic mineralisation
- Potential to host mafic-ultramafic intrusive related deposits
- High resolution airborne geophysics completed (57,477km were flown)
- Numerous features likely to represent large mafic-ultramafic intrusions.
- Targeted and basement lithology drilling program mid 2015

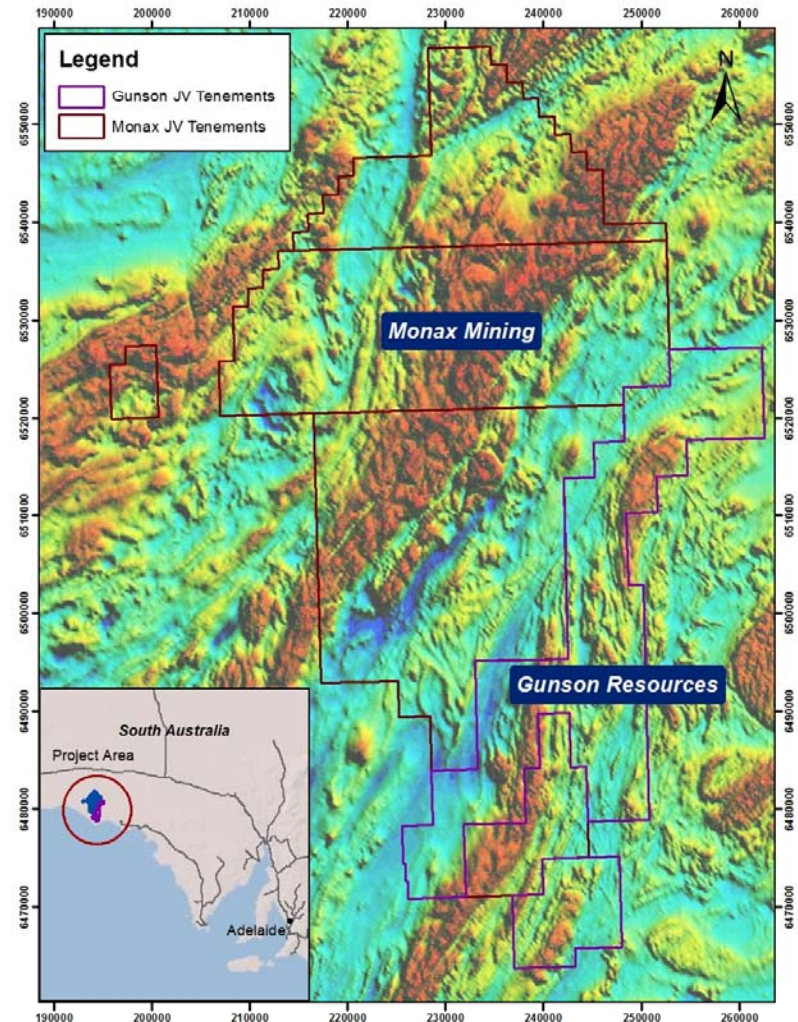

FINLAND – FINNAUST MINING PLC PROJECTS

- Listing on AIM completed in December 2013 and 60% WSA owned post listing
- Current market cap circa A\$10m
- 300km long base metal province in Finland
- Numerous nickel/copper/zinc mines & occurrences
- Recent drilling at the Hammaslahti Project:**
 - 5.6m at 3.2% Cu, 2.7% Zn, 0.7% Pb, 71gpt Ag and 0.76 gpt Au from 196.80m downhole.
 - Includes 8.65m at 2.2% Cu, 2.0% Zn, 0.5% Pb, 47gpt Ag and 0.50 gpt Au.
- Drilling commenced for potential extensions and repetitions to known copper deposits
- Geophysics proving very effective in defining targets - ZTEM survey completed

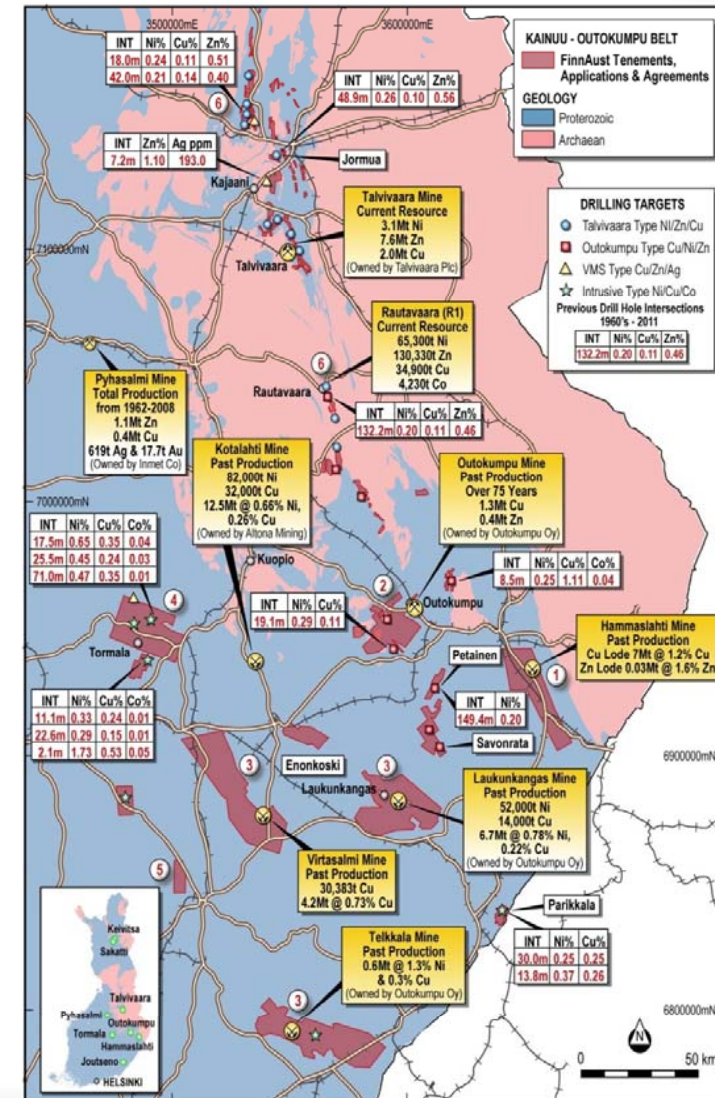

WESTERN AREAS VALUE EQUATION

- High Grade = Margin
- Survival

Highest Grade Nickel Globally



- Returns to shareholders in Dividends

Cashflow Positive



- Guidance continually met or exceeded

Strong Track Record of Delivery



- Looming shortage of nickel post Indo ban

Nickel Price Primed for Upside



- New mine successfully brought on in 24 months

History of Discovery and Development



- Flexibility in meeting future demands or opportunities

Strong Balance Sheet



WESTERN AREAS LTD

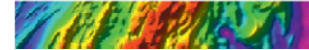

THE END



CORPORATE OVERVIEW

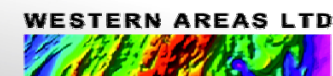

Board & Senior Management

Name	Position
Ian Macliver	Independent Non-Executive Chairman
Dan Lougher	Managing Director & CEO
David Southam	Executive Director
Joseph Belladonna	Chief Financial Officer & Company Secretary
Julian Hanna	Non-Executive Director
Richard Yeates	Independent, Non-Executive Director
Craig Readhead	Independent, Non-Executive Director
Tim Netscher	Independent, Non-Executive Director

Key Information

as at 12 February 2015

Share price	4.32
52 week high/low (A\$)	5.30 / 3.28
Shares outstanding (m)	232.6
Market Capitalisation (A\$m)	1,004.8
Cash (A\$m) ¹	178.7
Debt (A\$m) ¹	125.0
Undrawn ANZ Facility	125.0

1. Cash as at 31 December 2014 and face value of the convertible bond debt