

The ASDM logo consists of the letters 'ASDM' in a white, bold, sans-serif font, centered within a dark blue oval. This oval is superimposed on a larger, light blue circle that is partially visible at the top of the page.

ASDM

Rights Issue Prospectus

Advanced Surgical Design
& Manufacture Limited

ACN 066 281 132



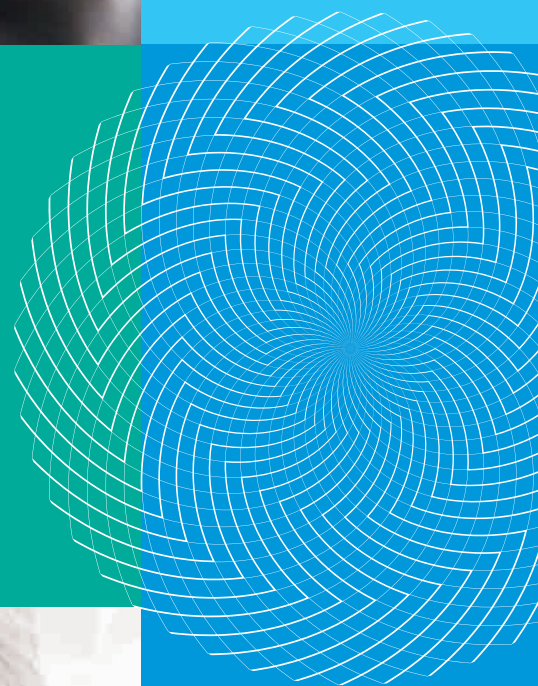

For a non-renounceable pro rata Rights Issue of New Shares and Top Up Shares by Advanced Surgical Design & Manufacture (“ASDM”) Limited to Eligible Shareholders at an Offer Price of \$0.05 each on the basis of 23 New Shares for every 50 Shares held at the Record Date to raise up to approximately \$1,006,279 before costs. The last date for acceptance and payment in full is 5.00 p.m. AEDT on 21 October 2014.

Important Notice

This document is important and requires your immediate attention. It should be read in its entirety. If you do not understand its contents or are in doubt as to the course you should follow, you should consult your broker, your accountant or other professional adviser.

Neither Advanced Surgical Design & Manufacture Limited nor any other person guarantees the performance of the New Shares and Top Up Shares offered pursuant to this Prospectus, or the performance of Advanced Surgical Design & Manufacture Limited, or the return on any investment.

Important Notices

This Prospectus is dated 26 September 2014.

A copy of this Prospectus was lodged with ASIC on 26 September 2014. ASDM will apply to ASX for quotation of the New Shares within 7 days after the date of this Prospectus. Neither ASIC nor the ASX take any responsibility for the contents of this Prospectus or the merits of the investment to which this Prospectus relates.

No securities will be allotted, issued or sold on the basis of this Prospectus later than 13 months after the date of this Prospectus.

This is a prospectus for an offer of continuously quoted securities (as defined in the Corporations Act) of Advanced Surgical Design & Manufacture Limited ("ASDM"; ASX: AMT) and has been prepared in accordance with Section 713 of the Corporations Act. Accordingly, this Prospectus does not contain the same level of disclosure as an initial public offering prospectus.

Disclaimer

In preparing this Prospectus, regard has been had to the fact that ASDM is a disclosing entity for the purposes of the Corporations Act. You should read this document in its entirety before deciding whether to invest in New Shares and Top Up Shares. In particular, you should consider the key risks that could affect the performance of ASDM or the value of an investment in ASDM, some of which are outlined in **Section 5**. However, the information provided in this Prospectus is not financial product advice and has been prepared without taking into account your investment objectives, financial circumstances or particular needs. Before

deciding whether to apply for New Shares and Top Up Shares, you should consider whether it is a suitable investment for you in light of your own investment objectives and financial circumstances and having regard to the merits or risks involved. If, after reading this Prospectus you have any questions about the Offer, or if you have any doubt, consult with your professional advisers before deciding whether to apply for New Shares and Top Up Shares. There are risks associated with an investment in ASDM and the New Shares and Top Up Shares offered under this Prospectus must be regarded as a speculative investment. The New Shares and Top Up Shares offered under this Prospectus carry no guarantee with respect to return on capital investment, payment of dividends or the future value of the New Shares or Top Up Shares.

Except as required by law, and only then to the extent so required, neither ASDM nor any other person warrants the future performance of ASDM, or any return on any investment made under this Prospectus.

As the Offer is non-renounceable you are unable to sell or transfer your Entitlement.

The information contained in this Prospectus has been prepared by ASDM and is the responsibility of ASDM. No person is authorised to give any information or make any representation in connection with the Offer described in this Prospectus which is not contained in this Prospectus. Any information or representation not contained in this Prospectus may not be relied on as having been authorised by ASDM in connection with the Offer. ASDM has prepared this document based on information available to

it at the time of preparation and none of ASDM, its associates or its advisers assumes any responsibility for the accuracy or completeness of that information.

Forward looking statements

Some of the statements appearing in this Prospectus may be in the nature of forward looking statements, including statements of current intention, statements of opinion and predictions as to possible future events. You should be aware that such statements are not statements of fact and there can be no certainty of outcome in relation to the matters to which the statements relate. Forward looking statements are subject to many inherent risks and uncertainties before actual outcomes are achieved. Actual outcomes may differ materially from the events, intentions or results expressed or implied in any forward looking statement in this Prospectus. To the full extent permitted by law, ASDM, the persons named in this Prospectus and any person involved in the preparation of this Prospectus makes no representation or warranty (express or implied) as to the accuracy or likelihood of fulfilment of any forward looking statement, or any intentions or outcomes expressed or implied in any forward looking statement. You are cautioned not to place undue reliance on any forward looking statement having regard to the fact that the outcome may not be achieved.

Restrictions on Distribution

This Prospectus does not constitute an offer in any place in

which, or to any person to whom, it would not be lawful to make the Offer. The distribution of this Prospectus in jurisdictions outside Australia and New Zealand may be restricted by law and persons who come into possession of this Prospectus should seek advice and observe any such restrictions. Any failure to comply with such restrictions may constitute a violation of applicable securities laws. It is the responsibility of any Applicant to ensure compliance with any laws of a country relevant to their Application. Return of a duly completed Entitlement and Acceptance form or payment in accordance with such form will be taken by ASDM as a representation that there has been no breach of such laws, that the Applicant is an Eligible Shareholder and that the Applicant is physically present in Australia or New Zealand.

Shareholders outside Australia and New Zealand should refer to **Section 2.8** of this Prospectus for further details.

The New Shares and Top Up Shares being offered to residents of New Zealand under this Prospectus are offered in reliance on the Securities Act (Overseas Companies) Exemption Notice 2002 (New Zealand).

This Prospectus has not been registered, filed with or approved by any New Zealand regulatory authority under the *Securities Act 1978* (New Zealand). This Prospectus is not an investment statement or prospectus under New Zealand law and is not required to, and may not, contain all the information that an investment statement or prospectus under New Zealand law is required to contain. The New Shares and Top Up Shares have not been, nor will they be,

registered under the United States Securities Act of 1933 or the securities laws of any other state in the United States and may not be offered or sold to, or for the account or benefit of, US persons.

New Share Trading

Individual applicants are responsible for determining their allocations of New Shares and Top Up Shares (if applicable) before trading in them. Eligible Shareholders trade in New Shares and Top Up Shares (if applicable) before receiving confirmation of their allocation at their own risk.

Prospectus Availability

This Prospectus is available in electronic form at www.asx.com.au, and copies of documents lodged with ASIC in relation to ASDM may be obtained from, or inspected at, an ASIC office.

Persons who access the electronic form of this Prospectus must ensure they download and read the entire Prospectus. The offer of New Shares and Top Up Shares pursuant to this Prospectus is available only to Shareholders of ASDM as at the Record Date and who are resident in Australia or New Zealand.

ASDM Shareholders may also obtain a hard copy of this Prospectus by calling ASDM's share registry Link Market Services Limited by telephone on 1300 911 275 (within Australia) and +61 1300 911 275 (outside Australia) between 8:30 am and 5:30 pm Monday to Friday.

Financial Amounts and Time

All references to currency are to Australian dollars and all references to time are to AEDT time, unless otherwise indicated.

Exposure Period

This Prospectus will be circulated during the Exposure Period. The purpose of the Exposure Period is to enable this Prospectus to be examined by market participants prior to the raising of funds. You should be aware that this examination may result in the identification of deficiencies in this Prospectus and, in those circumstances, any application that has been received may need to be dealt with in accordance with Section 724 of the Corporations Act.

Applications for Shares under this Prospectus will not be processed by ASDM until after the expiry of the Exposure Period. No preference will be conferred on applications lodged prior to the expiry of the Exposure Period.

Enquiries

If you have any enquiries in relation to the Offer please contact ASDM's share registry Link Market Services Limited by telephone on 1300 911 275 (within Australia) and +61 1300 911 275 (outside Australia) between 8:30 am and 5:30 pm Monday to Friday.

Glossary

Terms and abbreviations used in this Prospectus are explained in the Glossary at **Section 7** of this Prospectus.

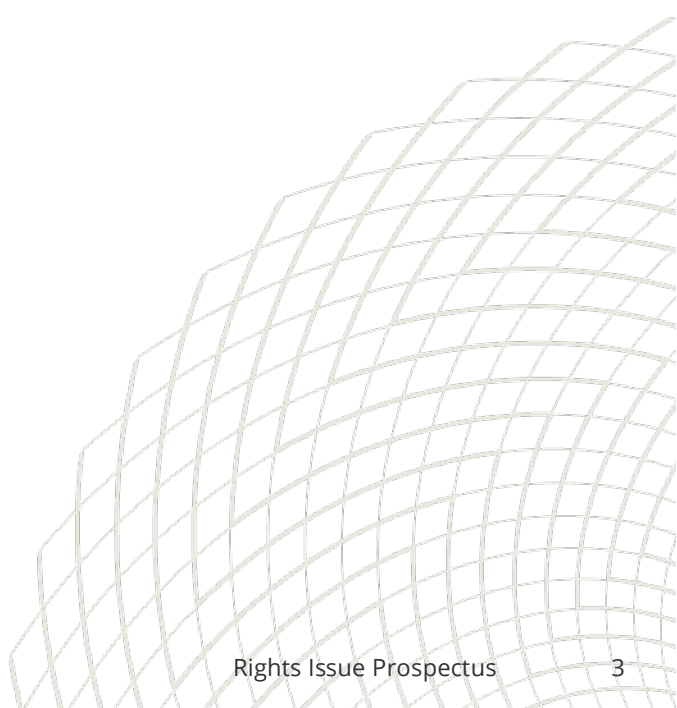

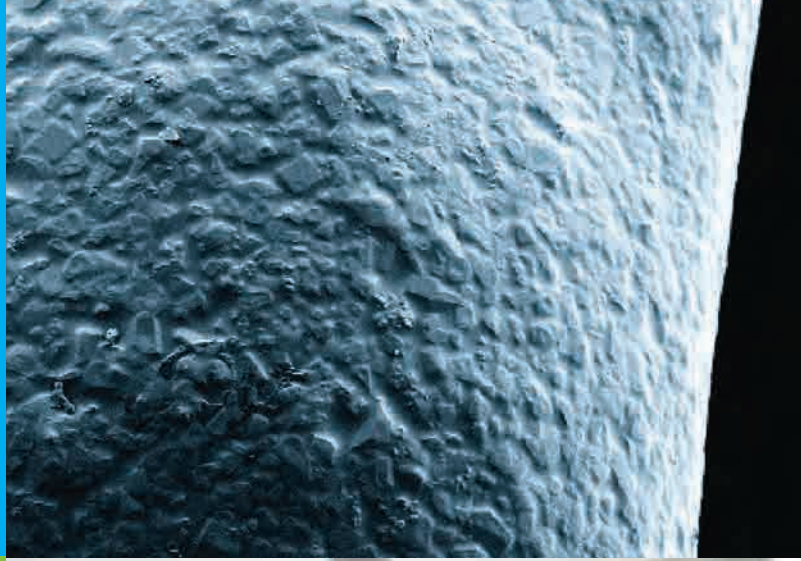

Table of Contents

Important Notices	1
Chairman's Letter	8
Key Offer Information	12
Important Dates and Important Notes	12
1. Overview	14
2. Details of the Offer	18
3. How to Apply	24
4. Effect of the Offer on ASDM	27
5. Key Risks	34
6. Additional Information	42
7. Glossary	56
8. Corporate Directory	58
Authorisation	59

New initiatives

ASDM is moving with innovative ideas, agility and ability into the next chapter of its development. Here is an overview of what is in motion.

collaboration with
research institutes
and surgeon
inventors

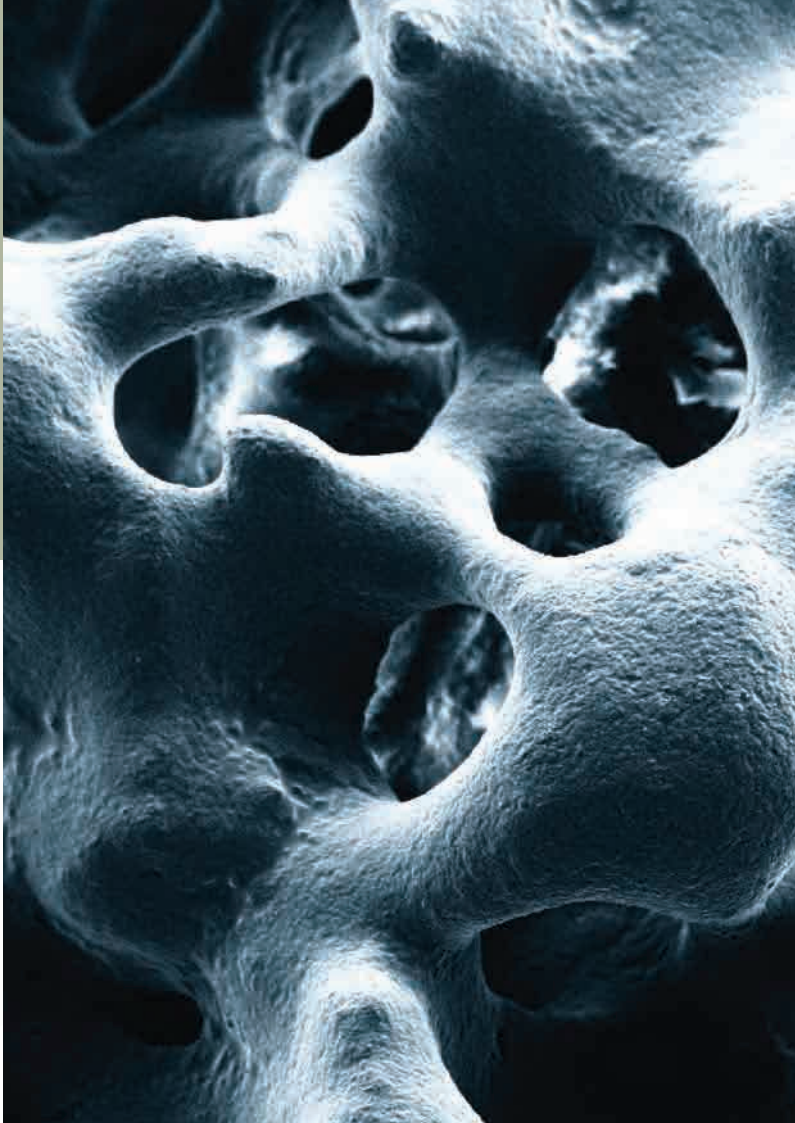
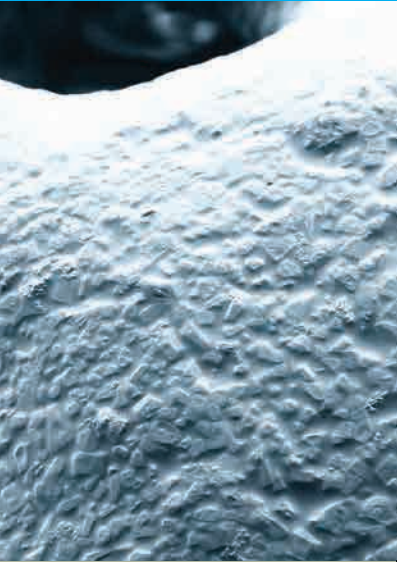

delivering
on innovation

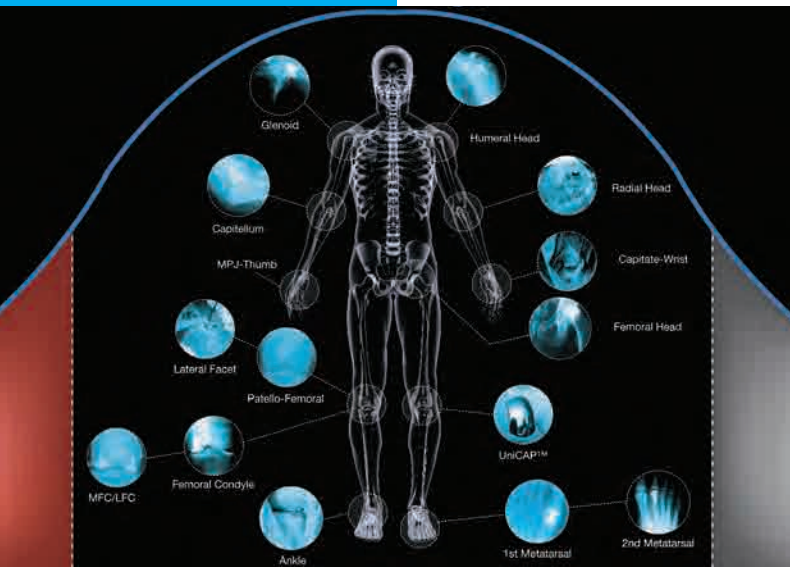

developing
highly trained
and skilled
medical devices
workforce

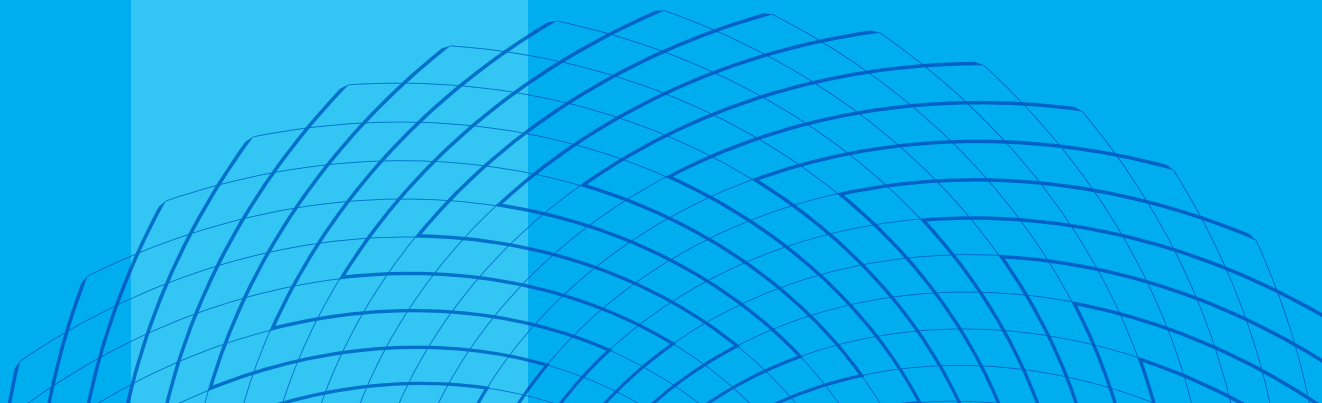

Chairman's Letter

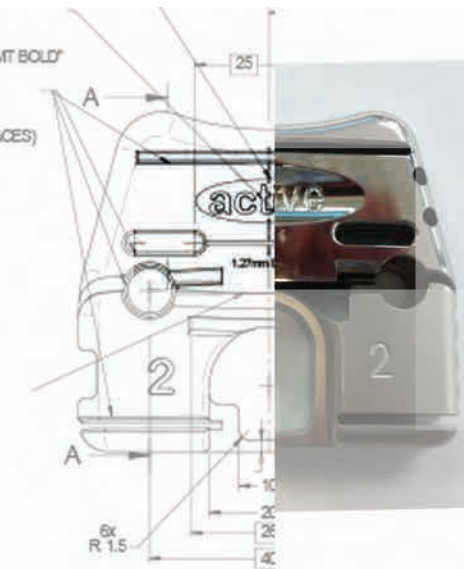

the next iteration
of the Active Knee
instrumentation

Dear Shareholder,

Advanced Surgical Design & Manufacture Limited (ASDM) is pleased to provide Eligible Shareholders the opportunity to participate in a non-renounceable pro rata Rights Issue. The Rights Issue gives Eligible Shareholders the opportunity for further involvement in the growth of ASDM by acquiring New Shares and Top Up Shares (where applicable).

ASDM is advancing into the next phase of our development as we maintain our focus on innovative ideas, agility and ability, through our local manufacturing and design footprint. Over the past 12-18 months, the company has been working closely with local innovators and surgeons to develop the next iteration of the Active Total Knee instrumentation. This development supports the Active Knee's long and successful clinical history with a new approach to surgical procedures that will pave the way to wider market segment opportunities.

During 2014, ASDM has partnered with the University of Sydney in the licensing of an exciting new technology in the ceramic bone scaffold area. This novel and breakthrough technology not only emphasises our focus on orthopaedics but also on industry collaboration in general.

In 2014-2015, we will be rolling out a new corporate brand identity that will underpin our commitment to our focus on opportunities in the future. Additionally, we will continue to concentrate on surgeon education and training through specialised cadaveric lab experiences that provide the fundamentals for the most effective and efficient patient outcomes.

ASDM is committed to developing a highly trained and skilled medical device workforce that collaborates with our partners to deliver innovation and patient focused outcomes.

In my position as Chairman, I will be taking up my entitlement. I encourage all shareholders to consider participating in this Offer and read this Prospectus in its entirety for all the details around the New Shares and Top Up shares.

On behalf of the Board of Directors, I would like to take this opportunity to thank all ASDM Shareholders for your continued and loyal support. We are looking forward to an exciting future as we seek to create an integrated, local, orthopaedic manufacturing success story.

Yours faithfully,

A handwritten signature in black ink, appearing to read 'Peter Kazacos', written over a light grey background.

Peter Kazacos

Chairman



Fast facts

The Offer will provide Eligible Shareholders with the **opportunity to subscribe for 23 New Shares for every 50 Shares** held on the Record Date at the Offer Price of \$0.05 per New Share and \$0.05 per Top Up Share (where applicable) under the Top Up Facility.

The Offer Price represents a 9.09% discount to ASDM's closing price of 5.5c as traded on the ASX at Thursday 25th of September 2014 and a 9.09% discount to the volume-weighted average price of ASDM's shares during the 5 trading days up to and including Thursday 25th of September 2014 (being the trading day before this Prospectus was finalised).

The Rights under the Offer will be non-renounceable, which means that entitlements to take up New Shares and Top Up Shares are non-transferable and will not be tradable on ASX. Shareholders who do not take up all or any part of their Entitlement will not receive any payment or value in respect of the Entitlement not taken up and their equity interest in ASDM will be diluted.

The Rights Issue is underwritten by Kaz Capital up to a maximum of \$1,000,000, on and subject to the terms of the Underwriting Agreement. The Rights Issue is sub-underwritten by Robinwood Investments Pty Limited up to a maximum of \$1,000,000 on and subject to the terms of the Sub-Underwriting Agreement. Further details of the underwriting and sub-underwriting arrangements are set out in **Section 6.4** of this Prospectus.

Please note that the **Closing Date for acceptances is 5.00pm (AEST) on 21 October 2014**. If you wish to participate in this Offer of New Shares and Top Up Shares it is essential that your completed personalised Entitlement and Acceptance Form is received by the Share Registry by this time.

For further information regarding the Offer, please contact ASDM share registry **Link Market Services Limited** by telephone on 1300 911 275 (within Australia) and +61 1300 911 275 (outside Australia) between 8:30a.m. and 5:30p.m. Monday to Friday.





new brand
bright future



local capability
and
manufacturing

Focus on education and training with an increase in Cadaver Labs

“That was a benchmark lab for me in terms of efficiency and density of information/experience.”

Surgeon comment



Active Knee -
clinical history,
new approach



Key Offer Information

Offer Price per New Share	A\$0.05
Offer Price per Top Up Share	A\$0.05
Eligible Shareholders' Entitlement	23 New Shares for every 50 Shares held on the Record Date
Approximate maximum Rights Issue Proceeds	A\$1,006,279
Approximate maximum number of New Shares to be issued pursuant to the Rights Issue	20,125,575 million New Shares
Approximate number of Shares on issue on completion of the Rights Issue	63,876,823 million Shares

Important Dates and Important Notes

Event	Date (business days)
Prospectus lodged with ASX and ASIC	26 September 2014
Appendix 3B lodged with ASX	26 September 2014
Notice sent to Shareholders	1 October 2014
"Ex" date (date from which securities trade on ASX without the entitlement to participate in the Offer)	2 October 2014
Record Date for Rights Issue	7 October 2014
Prospectus and Entitlement and Acceptance Forms despatched to Eligible Shareholders	10 October 2014
Opening Date for Offer	13 October 2014
Closing Date for acceptance and payment	21 October 2014
Deferred settlement trading ends	22 October 2014

ASX notified of under-subscriptions	24 October 2014
Issue date	28 October 2014
Deferred settlement trading ends	28 October 2014
Commencement of normal trading of New Shares on ASX	29 October 2014

All dates (other than the date of the Prospectus and date of lodgement of the Prospectus with ASX and ASIC) are indicative only. The Directors reserve the right, subject to the Corporations Act, the ASX Listing Rules and the approval of the Underwriter, to extend the Closing Date or to withdraw the Rights Issue without further notice. A change to the Closing Date may cause other key dates to change.



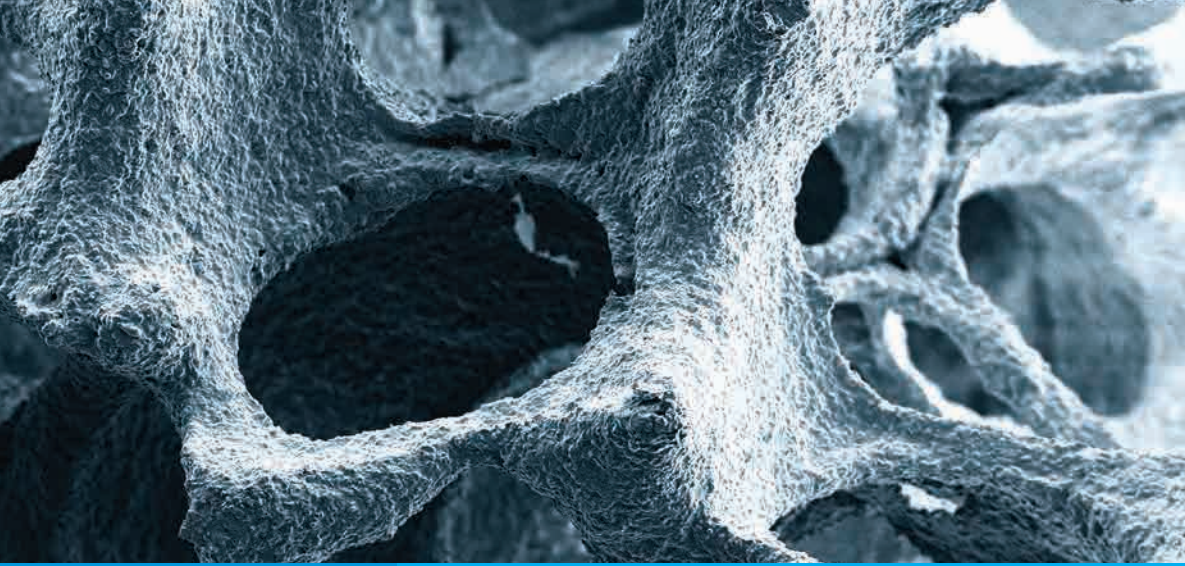

Overview



1. Overview

1.1. The Offer

		Section Number
What is the Offer?	The Offer is a pro-rata non-renounceable offer made to Eligible Shareholders to subscribe for New Shares and Top Up Shares (under the Top Up Facility) where there is a sufficient shortfall and Eligible Shareholders have subscribed for their full Entitlement.	2.2
What is my Entitlement?	Each Eligible Shareholder is entitled to subscribe for 23 New Shares for every 50 Shares held on the Record Date, subject to the terms of this Prospectus.	2.2
What is the Offer Price?	The Offer Price is \$0.05 per New Share and \$0.05 per Top Up Share.	2.7
Am I an Eligible Shareholder?	Eligible Shareholders are those persons who: <ul style="list-style-type: none">• are registered as a Shareholder as at 7.00pm, (AEDT) on the Record Date; and• have an address in Australia or New Zealand as recorded on the Share Registry as at the Record Date.	2.3
How much will be raised from the Offer?	The Offer will raise approximately \$1,006,279 (before costs).	2.1
What is the purpose of the Offer and how will the funds raised be used?	ASDM is undertaking the Offer to accelerate research and development and sales projects and to undertake the corporate re-branding of ASDM. See Section 2.1 for further details.	2.1
Is the Offer Underwritten?	Yes, the Offer is underwritten by Kaz Capital Pty Ltd (" Underwriter ") up to a maximum of \$1,000,000, on and subject to the terms of the Underwriting Agreement and sub-underwritten by Robinwood Investments Pty Limited (Robinwood) (" Sub-Underwriter ") up to a maximum of \$1,000,000 on and subject to the terms of the Sub - Underwriting Agreement. See Section 6.4 for further details.	6.4
What are the tax implications of participating in the Offer?	Tax implications will vary depending upon the specific circumstances of individual Shareholders. Investors should obtain their own professional advice as to the particular taxation treatment which will apply to them.	2.16

Can I apply for Additional New Shares above my Entitlement?	Yes, Eligible Shareholders who take up their full Entitlement may apply for Top Up Shares under the Top Up Facility, subject to their being a sufficient shortfall and subject to ASDM's discretion.	2.6
Are there any risks?	There are risks associated with an investment in ASDM. These include risks relating to ASDM's business, risks associated with investing in the medical industry generally, risks relating to the Offer and risks associated with financial investment generally. The risks are set out in more detail in Section 5 of this Prospectus.	5
Where can I find more information about ASDM?	For more information on ASDM and its projects please see ASDM's website (www.asdm.com.au) and ASDM's ASX announcements (www.asx.com.au).	

1.2. Actions for Eligible Shareholders

		Section Number
How do Eligible Shareholders find out what their Entitlement is?	Your Entitlement is set out in the personalised Entitlement and Acceptance Form accompanying this Prospectus.	3.1
What can I do with my Entitlement?	<p>You can do the following:</p> <ul style="list-style-type: none"> • take up all or part of your Entitlement; or • do nothing, in which case your Entitlement will lapse. <p>If you take up your full Entitlement you may also choose to apply for Top Up Shares as described in Section 2.6.</p>	3.2 & 3.3
Can I trade my Entitlement?	No, the Offer is non-renounceable meaning you cannot trade your Entitlement.	2.4
What happens if I do not take up my Entitlement, or take up on part of my Entitlement?	If you do not take up all of your Entitlement by the Closing Date, then New Shares representing the number of New Shares not taken up under your Entitlement will form part of the Top Up Facility. This will likely result in your interest in ASDM being diluted.	3.3

How do I accept the Offer? And how do I apply for Top Up Shares?

If you wish to take up all or part of your Entitlement (and if upon taking up all your Entitlement you wish to apply for Top Up Shares), you must:

- complete the Entitlement and Acceptance Form in accordance with the instructions set out in the form (if you have applied to take up all your Entitlement, you may also apply for Top Up Shares under the Top Up Facility – see **Section 2.6** for further details); and
- return the completed Entitlement and Acceptance Form together with payment of Application Money in accordance with **Section 3** of this Prospectus to the following address so that it is received by no later than 5:00pm (AEDT) on the Closing Date (or such other date as ASDM may determine):

Advanced Surgical Design and Manufacture
Limited
C/- Link Market Services Limited
Reply Paid 3560
Sydney NSW 2001

3

1.3. Further Information

If you have any questions about the Offer that are not answered in this Prospectus you should consult your broker, accountant, solicitor or other professional adviser before deciding to invest or contact ASDM's share registry Link Market Services Limited by telephone on 1300 911 275 (within Australia) and +61 1300 911 275 (outside Australia) between 8:30 am and 5:30 pm Monday to Friday.



Details of the Offer



2. Details of the Offer

2.1. Purpose of the Offer and use of funds

It is intended that funds raised under the Rights Issue will be used to accelerate research and development and sales projects and to undertake the corporate re-branding of ASDM.

If the Offer is fully subscribed, it will result in ASDM raising approximately \$1,006,279 (before costs). The table below sets out the proposed use of the proceeds of the Offer (assuming full subscription):

Description of use of proceeds	Amount
Acceleration of R&D/Sales Projects	\$820,000.00
Corporate Rebranding	\$56,279.00
Offer costs	\$130,000.00

The proposed use of proceeds set out above is a statement of current intentions as at the date of this Prospectus only. As with any budget, intervening events and new circumstances have the potential to affect the ultimate way in which the proceeds will be applied.

2.2. The Offer

ASDM is making a non-renounceable pro rata Rights Issue offer to Eligible Shareholders to apply for New Shares and Top Up Shares. Each Eligible Shareholder is entitled to apply for 23 New Shares for every 50 Shares held at an issue price of \$0.05 per New Share.

Eligible Shareholders who take up their full Entitlement can also apply for Top Up Shares in accordance with **Section 2.6** of this Prospectus.

Eligible Shareholders are being sent this Prospectus together with a personalised Entitlement and Acceptance Form and are invited to apply for New Shares and Top Up Shares. Fractional entitlements will be rounded up to the nearest whole number of New Shares and Top Up Shares.

All Eligible Shareholders who subscribe for their Entitlement will receive their Entitlement in full. To the extent that an Eligible Shareholder does not take up their Entitlement, the interest of that Shareholder in ASDM may be diluted.

Subject to rounding, ASDM will issue up to approximately 20,125,575 New Shares and Top Up Shares (if applicable) to raise up to approximately \$1,006,279 (before costs).

The Offer opens on 13 October 2014 and is scheduled to close at 5.00pm (AEDT) on 21 October 2014.

2.3. Eligible Shareholders

Eligible Shareholders are those persons who:

- are registered as a Shareholder as at 7.00pm (AEDT) on the Record Date; and
- have an address in Australia or New Zealand as recorded on the Share Registry as at the Record Date.

2.4. Non – renounceable

The Offer is non-renounceable. There will be no trading of Rights on the ASX and Rights may not be sold.

2.5. Rounding and Share Splitting

All Rights will be rounded up to the nearest whole number of New Shares and Top Up Shares.

If ASDM reasonably believes that a Shareholder has been a party to the splitting or division of a shareholding in an attempt to obtain an advantage from the rounding up of Rights, then ASDM reserves the right to round the Rights of such holdings so as to provide only the number of New Shares and Top Up Shares that would have been received but for the splitting or division

2.6. Top Up Shares and Top Up Facility

Any New Shares not taken up by the Closing Date form part of the Top Up Facility.

Subject to the Corporations Act and the requirements of the Listing Rules, Eligible Shareholders who subscribe for their full Entitlement may apply for more New Shares than the numbers shown on their Entitlement and Acceptance Form. That is, those Shareholders may apply for Top Up Shares. The issue price of each Top Up Share will be \$0.05 (five cents), being the same price for New Shares under the Offer.

The Application Amount for Top Up Shares is calculated as follows:

$$\text{Application Amount} = \text{Number of Top Up Shares applied for} \times \text{Top Up Share Price}$$

Top Up Shares will only be allocated to Eligible Shareholders, if and to the extent that ASDM so determines, in its absolute discretion, having regard to circumstances as at the time of the close of the Offer and subject to the Corporations Act and the ASX Listing Rules.

The number of the New Shares under the Top Up Facility will not exceed the lesser of 5,000,000 Shares (\$250,000.00) and the shortfall from the Offer. There is no guarantee that you will receive Top Up Shares and ASDM does not guarantee that any application for Top Up Shares will be successful. In particular, ASDM may allocate to an Eligible Shareholder a lesser number of Top Up Shares than the Eligible Shareholders applied for, or reject any Application for Top Up Shares. If the number of Top Up Shares allotted to an Eligible Shareholder is less than the number applied for by that Eligible Shareholder, surplus Application Money will be refunded in full. Interest will not be paid on monies refunded.

If ASDM decides to issue Top Up Shares, the Top Up Shares will be allotted at the same time as the New Shares under the Offer are allotted. ASDM's decision on the number of Top Up Shares allocated to Eligible Shareholders will be final.

2.7. Offer Price

The Offer Price is \$0.05 per New Share and \$0.05 per Top Up Share. This is payable on taking up your Entitlement and any application for Top Up Shares.

The Offer Price represents a 9.09% discount to ASDM's closing price of 5.5c as traded on the ASX at Thursday 25th of September 2014 and a 9.09% discount to the volume-weighted average price of ASDM's shares during the 5 trading days up to and including Thursday 25th of September 2014 (being the trading day before this Prospectus was finalised).

2.8. Treatment of Overseas Shareholders

The Offer is not being extended to any Shareholder, as at the Record Date, whose registered address is not in Australia or New Zealand due to the small number of such Shareholders, and the cost of complying with regulatory requirements in jurisdictions outside of Australia and New Zealand.

This Prospectus and the accompanying personalised Entitlement and Acceptance Form does not constitute an offer of New Shares and Top Up Shares in any jurisdiction in which, or to any person to whom, it would be unlawful to make such an offer. Return of a duly completed Entitlement and Acceptance Form will be taken by ASDM to constitute a representation by the Applicant that there has been no breach of applicable securities laws. The distribution of this Prospectus in jurisdictions outside Australia and New Zealand may be restricted by law and anyone who receives this Prospectus should seek advice on and observe such restrictions. Any failure to comply with such restrictions may constitute a violation of applicable securities laws. No action has been taken to register or qualify the New Shares, Top Up Shares or the Offer, or otherwise permit a public offering of New Shares and Top Up Shares in any jurisdiction outside Australia. New Shares and Top Up Shares may not be offered or sold in any country outside Australia except to the extent permitted below. It is the responsibility of any Applicant to ensure compliance with any laws of the country relevant to their application. Return of a duly completed personalised Entitlement and Acceptance Form and/or payment of Application Money will be taken by ASDM to constitute a representation that there has been no breach of such laws and that the Applicant is physically present in Australia or New Zealand.

2.8.1. New Zealand

The New Shares and Top Up Shares are not being offered or sold to the public within New Zealand other than to existing Shareholders of ASDM with registered addresses in New Zealand to whom the offer of New Shares and Top Up Shares is being made in reliance on the Securities Act (Overseas Companies) Exemption Notice 2002 (New Zealand).

This Prospectus has not been registered, filed with or approved by any New Zealand regulatory authority under the *Securities Act 1978* (New Zealand). This Prospectus is not an investment statement or prospectus under New Zealand law and is not required to, and may not, contain all the information that an investment statement or prospectus under New Zealand law is required to contain.

2.9. CHESS

ASDM participates in the Clearing House Electronic Subregister System (CHES). ASX Settlement and Transfer Corporation Pty Ltd (ASTC), a wholly owned subsidiary of ASX, operates CHES in accordance with the ASX Listing Rules, ASTC Settlement Rules and ACH Clearing Rules.

Under CHES, Applicants will not receive a certificate but will receive a statement of their holding of New Shares and Top Up Shares.

If you are broker sponsored, ASTC will send you a CHES statement. The CHES statement will set out the number of New Shares and Top Up Shares issued to you under this Prospectus, and provide details of your holder identification number and the participant identification number of the sponsor.

If you are registered on the Issuer Sponsored sub-register, your statement will be despatched by the Share Registry and will contain the number of New Shares and Top Up Shares issued to you under this Prospectus and your security holder reference number.

A CHES statement or Issuer Sponsored statement will routinely be sent to Shareholders at the end of any calendar month during which the balance of their shareholding changes.

Shareholders may request a statement at any other time. However, a charge may be made for additional statements.

2.10. Allotment and Official Quotation of New Shares and Top Up Shares

ASDM will apply to ASX for the official quotation of the New Shares and Top Up Shares within 7 days after the date of this Prospectus. Subject to approval being granted, it is expected that normal trading of New Shares and Top Up Shares issued under the Rights Issue will commence on 29 October 2014. If ASX does not permit quotation within three months from the date of this Prospectus, the Application Monies will be refunded in full without interest. Holding statements are expected to be despatched to Eligible Shareholders on 29 October 2014.

It is the responsibility of each Applicant to confirm their holding before trading in New Shares and Top Up Shares (if applicable) commences. Any Applicant who sells New Shares and Top Up Shares (if applicable) before receiving confirmation of their holding in the form of their holding statement will do so at their own risk. ASDM disclaims all liability whether in negligence or otherwise (and to the maximum extent permitted by law) to persons who trade New Shares and Top Up Shares (if applicable) before receiving their holding statements, whether on the basis of confirmation of the allocation provided by ASDM or the Share Registry.

2.11. Application Money

Until New Shares and any Top Up Shares are issued, ASDM will hold the Application Money on trust for each participating Eligible Shareholder in bank accounts in Australia. If it becomes necessary, the Application Money will be refunded as soon as reasonably practicable, without interest.

All Application Monies will be held by ASDM in a bank account on trust for Applicants until the New Shares and any Top Up Shares are issued or, if the New Shares are not issued, until the Application Monies are returned to Applicants.

The bank account will be established and maintained by Link Market Services on behalf of ASDM solely for the purposes of depositing Application Monies and retaining those funds for as long as required under the Corporations Act.

Interest earned on the Application Monies will be for the benefit of, and will remain the property of, ASDM and will be retained by ASDM whether or not the allotment and issue of New Shares or any Top Up Shares take place. Amounts received by ASDM in excess of your Entitlement (**Excess Amount**) may be treated as an application to apply for as many Top Up Shares as your Excess Amount will pay for in full.

Alternatively, your application may not be accepted.

Any Application Monies received for more than your final allocation of New Shares and Top Up Shares (if any) will be refunded as soon as practicable after the Closing Date (except for where the amount is less than the Offer Price, in which case it will be retained by ASDM). If the New Shares and Top Up Shares (if any) are not issued to you, a cheque will be drawn and relevant Application Monies will be refunded as soon as practicable after the Closing Date.

2.12. Withdrawal of the Offer

ASDM reserves the right to withdraw the Offer at any time, in which case ASDM will refund Application Monies in accordance with the Corporations Act and will do so without interest.

2.13. Underwriting

Kaz Capital has agreed to underwrite the first \$1,000,000.00 of the Rights Issue to a maximum of \$1,000,000.00 (**Underwritten Amount**) pursuant to an underwriting agreement between ASDM and Kaz Capital (**Underwriting Agreement**).

The Rights Issue is sub-underwritten by Robinwood up to a maximum of \$1,000,000, pursuant to a sub-underwriting agreement between Kaz Capital and Robinwood (**Sub-underwriting Agreement**).

Further details of the underwriting and sub-underwriting arrangements are set out in **Section 6.4** of the Prospectus.

2.14. Closing Date

The Closing Date for acceptance of your Entitlement is 5.00p.m. (AEDT) on 21 October 2014.

If you wish to participate in this Offer of New Shares and Top Up Shares it is essential that your completed Entitlement and Acceptance Form along with your Application Money are received by ASDM's Share Registry by the Closing Date.

2.15. Rights and liabilities attaching to New Shares and Top Up Shares

New Shares and Top Up Shares issued pursuant to the Rights Issue will be fully paid ordinary shares in the capital of ASDM and will rank equally with Shares.

The rights and liabilities attaching to Shares are set out in ASDM's Constitution and are regulated by the Corporations Act, the general law, the Listing Rules and the ASTC Settlement Rules.

2.16. Taxation Implications

Shareholders should be aware that there may be taxation implications of participating in the Offer and subscribing for New Shares and any Top Up Shares. The taxation consequences of participating in the Offer and / or acquiring New Shares and Top Up Shares may vary depending on the individual circumstances of each Shareholder.

Shareholders should consult their own professional taxation advisers to obtain advice in relation to the taxation laws and regulations applicable to their personal circumstances.

2.17. Privacy Act

If you complete the personalised Entitlement and Acceptance Form accompanying this Prospectus you will be providing personal information to ASDM albeit directly to its Share Registry. ASDM will use that information to assess your application.

The information may also be used for other purposes from time to time and may be disclosed to persons inspecting the register, regulatory bodies (including The Australian Taxation Office), authorised securities brokers, print service providers, mail houses and the Share Registry itself.

You can access, correct and update the personal information that ASDM holds about you. Please contact the Share Registry on 1300 911 275 (within Australia) +61 1300 911 275 (outside Australia) if you wish to do so. Collection, maintenance and disclosure of certain personal information is governed by legislation including *The Privacy Act 1988* (Cth) (as amended) and the Corporations Act. If you do not provide the information required to be completed on the Entitlement and Acceptance Form ASDM may not be able to accept or process your application.

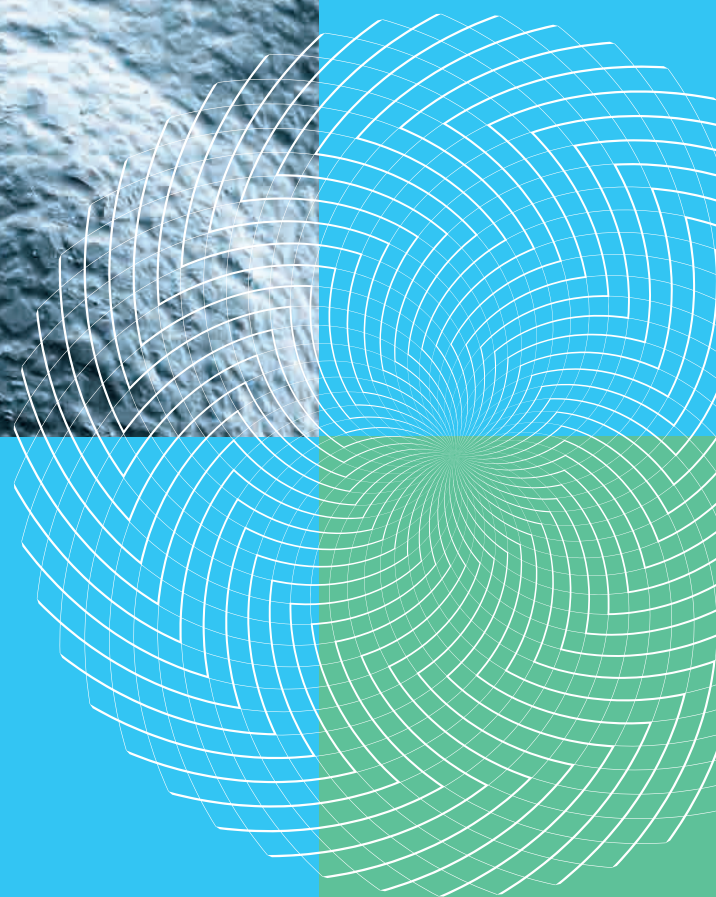

How to apply

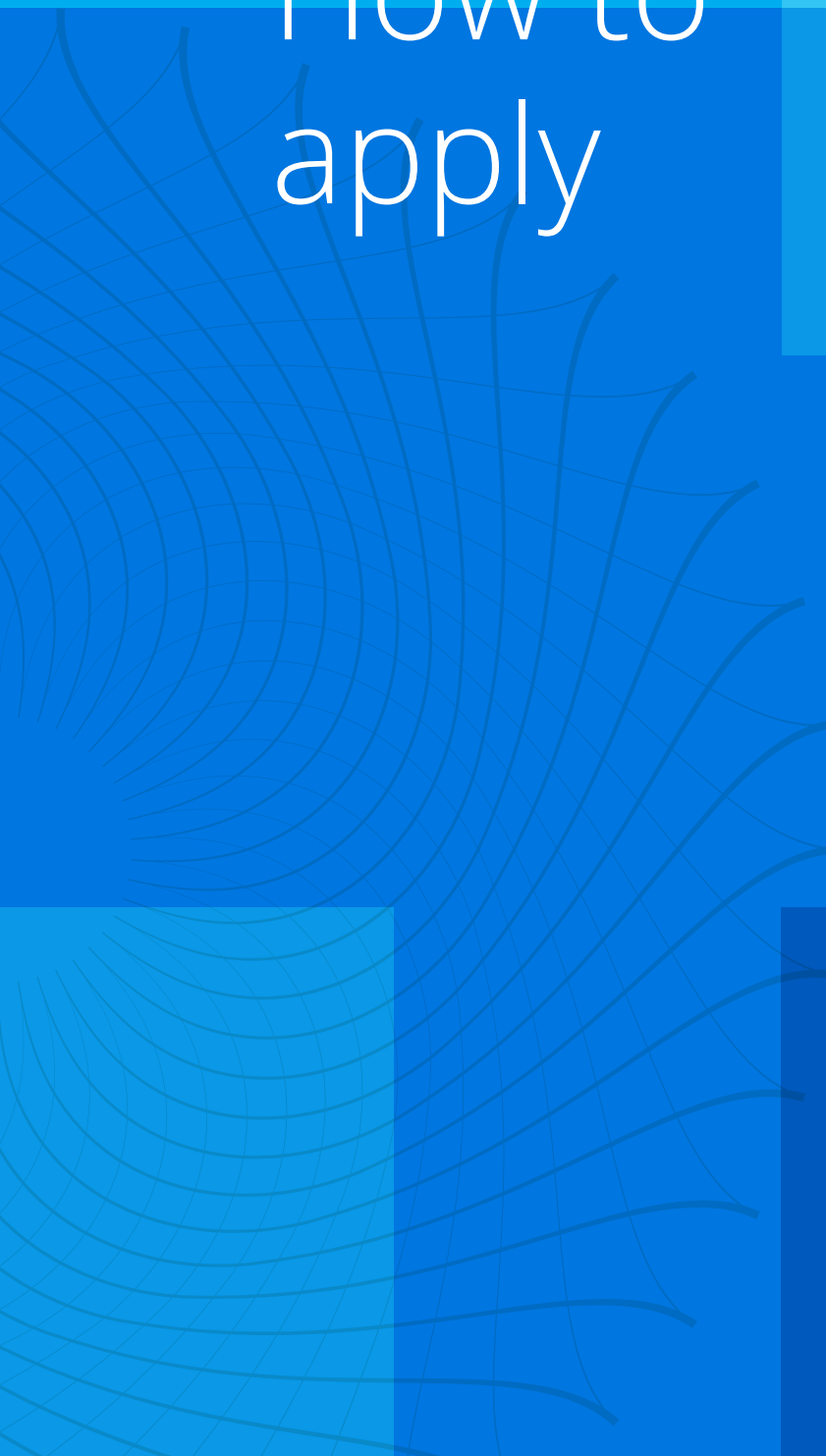

3. How to Apply

3.1. Eligible Shareholders Choices

The number of New Shares to which you are entitled is shown on the personalised Entitlement and Acceptance Form accompanying this Prospectus.

Eligible Shareholders may:

- subscribe for their Entitlement in full and, if they do so, they may apply for Top Up Shares under the Top Up Facility (see **Section 3.2 (full Entitlement)** and **Section 2.6 (Top Up Shares)**);
- subscribe for part of their Entitlement, in which case the balance of the Entitlement would lapse (see **Section 3.2**); or
- allow their Entitlement to lapse (see **Section 3.3**).

3.2. Subscription for all or part of your Entitlement

If you are an Eligible Shareholder and wish to take up all or part of your Entitlement:

- complete the Entitlement and Acceptance Form in accordance with the instructions set out in the form (if you have subscribed for all your Entitlement, you may also apply for Top Up Shares under the Top Up Facility – see **Section 2.6** for further details); and
- return the completed Entitlement and Acceptance Form together with payment of the Application Money in accordance with **Section 3.4** of this Prospectus to the following address so that it is received by no later than 5:00pm (AEDT) on the Closing Date (or such other date as ASDM may determine):

Advanced Surgical Design and Manufacture Limited
C/- Link Market Services Limited
Reply Paid 3560
Sydney NSW 2001
Australia

If you wish to subscribe for part of your Entitlement and allow the balance to lapse, complete the Entitlement and Acceptance Form by indicating the number of New Shares you wish to accept.

The Application Amount for taking up part of your Entitlement is calculated as follows:

$$\text{Application Amount} = \text{Number of New Shares applied for} \times \text{New Share Price}$$

3.3. Allowing your Entitlement to Lapse

If you do not wish to take up any part of your Entitlement you are not required to take any action. Although you will continue to own the same number of Shares, your percentage shareholding in ASDM may be diluted.

3.4. Payment Instructions

The Offer Price of \$0.05 per New Share and \$0.05 per Top Up Share is payable in full on exercise of your Entitlement.

The Application Money must be received at ASDM's Share Registry by no later than the Closing Date (or such other date as ASDM may determine).

You may pay the Application Money by cheque, bank draft, money order or BPAY®. In choosing a payment method, Shareholders should be aware of the time required to process payments by cheque, bank draft, money order and BPAY®.

Cash will not be accepted and receipts will not be issued. Please note that funds are unable to be directly debited from your bank account.

If you provide insufficient funds to meet the Application Money payable, you may be taken by ASDM to have applied for such lower number of New Shares as your cleared Application Money will allow for, or your Application may be rejected.

3.4.1. Payment by Cheque, Bank Draft or Money Order

To pay by cheque, bank draft or money order, your cheque, money order or bank draft must be made in Australian currency and drawn on an Australian branch of a financial institution. Such payment must be made payable to **Advanced Surgical Design & Manufacture** and crossed **“Not Negotiable”**. Payments not properly drawn may be rejected.

Cheques will be processed on the day of receipt and sufficient cleared funds must be held in your account as cheques returned unpaid may not be re-presented and may result in your Entitlement and Acceptance Form being rejected. Paperclip (do not staple) your cheque(s) to the form where indicated.

3.4.2. Payment by BPAY®

Payment can be made using BPAY® in accordance with the instructions for BPAY® set out in your personalised Entitlement and Acceptance Form using the biller code and unique reference number on the form. If you require further information in relation to using BPAY® please contact your bank, credit union or building society.

If you are applying for shares and your payment is being made by BPAY®, you do not need to return your Entitlement and Acceptance Form. Your payment must be received by no later than the Closing Date. Applicants should be aware that their own financial institution may implement earlier cut off times with regards to electronic payment, and should therefore take this into consideration when making payment. It is the responsibility of the Applicant to ensure that funds submitted through BPAY® are received by this time.

3.5. Entitlement and Acceptance Form is binding

A completed and lodged Entitlement and Acceptance Form constitutes a binding offer to acquire New Shares and Top Up Shares (where applicable) on the terms and conditions set out in this Prospectus and, once lodged, cannot be withdrawn. If the Entitlement and Acceptance Form is not completed correctly it may still be treated as a valid application for New Shares and Top Up Shares (where applicable). The Board's decision whether to treat an Acceptance as valid and how to construe, amend or complete the Entitlement and Acceptance Form is final.

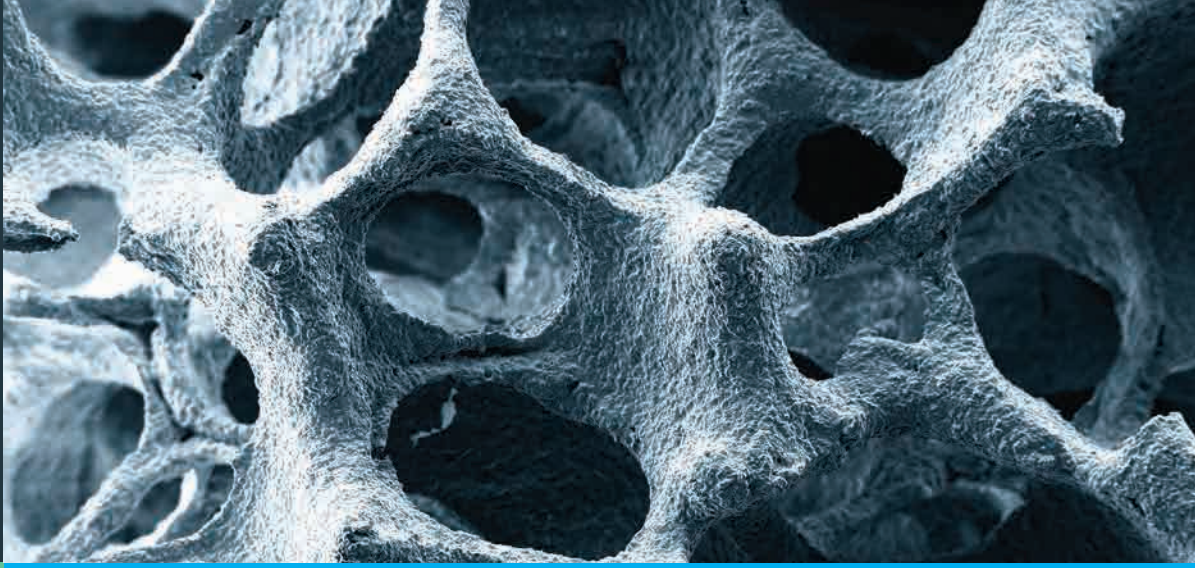
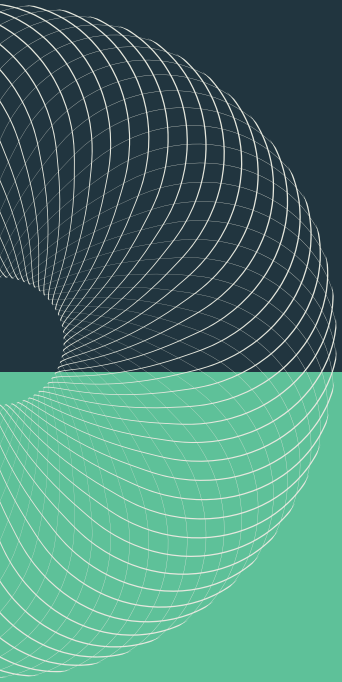

Effect of the Offer on ASDM

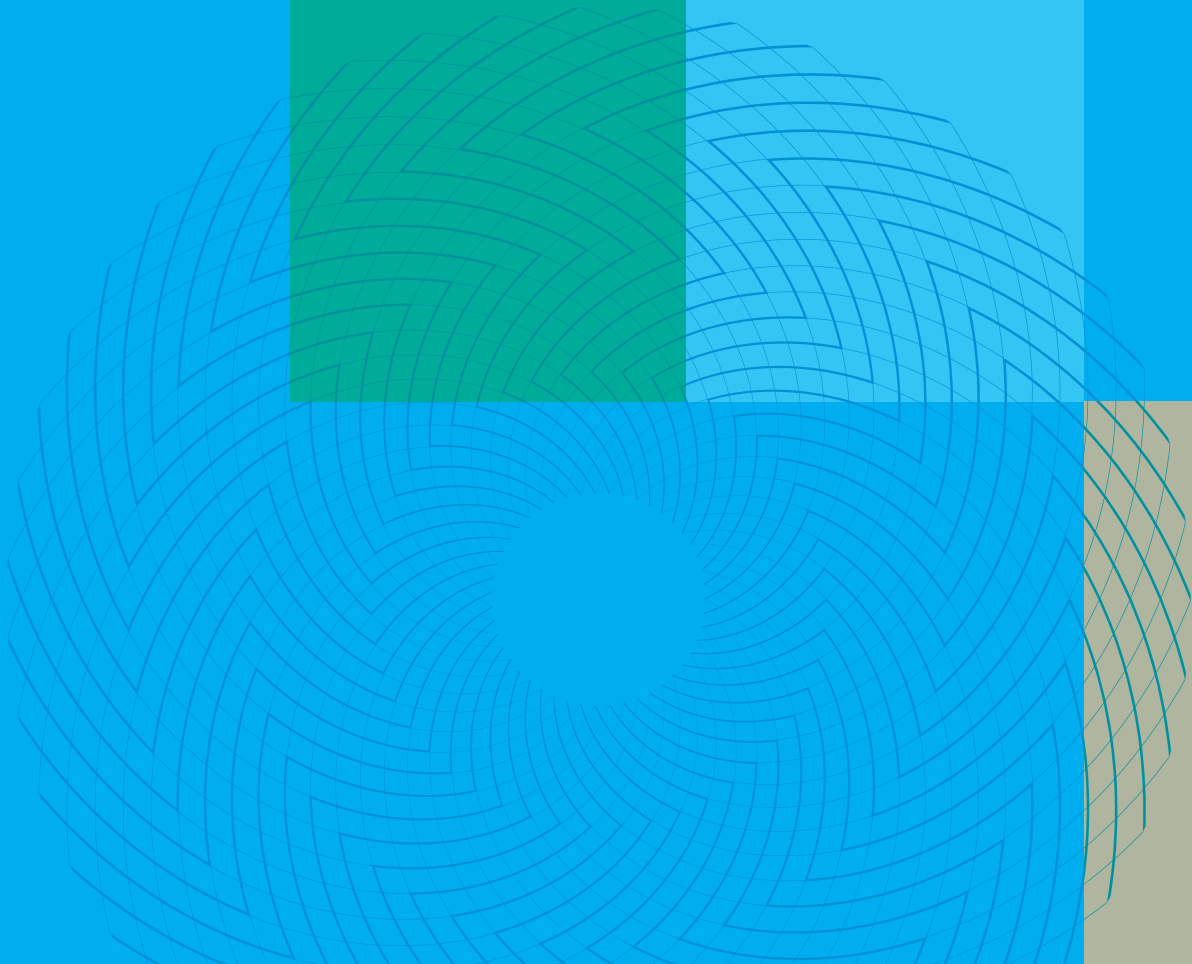

4. Effect of the Offer on ASDM

4.1. Effect of Rights Issue on Financial Position

4.1.1. Introduction

This section provides relevant financial information for Shareholders to consider when assessing whether to participate in the Rights Issue, including details of the potential financial impact of the Rights Issue.

All information in this section assumes that the Rights Issue took place on 30 June 2014. To the extent that the actual date varies, information presented may vary considerably.

The pro forma financial information should be read in conjunction with the limitations explained in the Important Notices section and other sections of this Prospectus.

The impact of the Rights Issue and Underwriting is an increase in cash of up to approximately A\$1,006,279 and no less than A\$1,000,000 (being the amount underwritten). The use of funds from the Rights Issue is discussed in **Section 2.1** of this Prospectus.

4.1.2. Pro Forma Balance Sheet

To illustrate the expected effect of the Rights Issue on ASDM, an unaudited pro forma balance sheet has been prepared as at 30 June 2014 to illustrate the financial position of ASDM following completion of the Offer, assuming in the first instance that the Offer is fully subscribed and in the alternative, that the Offer is subscribed up to the Underwritten Amount, in each instance after deducting expenses of the Offer of \$130,000 (excluding GST). This pro-forma unaudited balance sheet is illustrative only and may not reflect the actual position and balances as at the date of this Offer or the conclusion of this Offer.

The unaudited pro forma balance sheet has been prepared on a going concern basis, which contemplates the continuity of normal business activity and the realisation of assets and settlement of liabilities in the normal course of business.

Advanced Surgical Design & Manufacture Limited			
	Unaudited Jun-14	Fully Subscribed	Fully Underwritten
Cash on hand	26,017	902,295	896,017
Trade and other receivables	2,290,146	2,290,146	2,290,146
Inventory	3,265,963	3,265,963	3,265,963
Total Current Assets	5,582,126	6,458,404	6,452,126
Prepayments and other assets	122,797	122,797	122,797
Property, plant and equipment	2,115,350	2,115,350	2,115,350
Intangible assets - Patents & Website	213,136	213,136	213,136
Total Assets	2,451,283	2,451,283	2,451,283
Trade Creditors	1,655,598	1,655,598	1,655,598

Borrowings	1,566,442	1,566,442	1,566,442
Provision for LSL	147,668	147,668	147,668
Current Liabilities	3,369,708	3,369,708	3,369,708
Borrowings	233,187	233,187	233,187
Provisions LS Leave and Make Good	257,307	257,307	257,307
Long term Liabilities	490,494	490,494	490,494
Total Liabilities	3,860,202	3,860,202	3,860,202
Net Assets	4,173,206	5,049,484	5,043,206
Equity			
Share Capital	9,602,217	10,478,495	10,472,217
Share Capital Reserve	550,780	550,780	550,780
Retained Earnings	(5,979,790)	(5,979,790)	(5,979,790)
Total Equity	4,173,207	5,049,485	5,043,207

4.1.3. Expenses of Offer

	Offer fully subscribed (\$)	Offer subscribed up to the underwritten amount (\$)
Fees payable to the Underwriter by ASDM	\$50,000, of which \$35,000 is payable to the Sub-Underwriter	\$50,000, of which \$35,000 is payable to the Sub-Underwriter
Legal Fees	\$13,000	\$13,000
Offer related Fees (including fees payable to Kaz Capital for managing the Rights Offer)	\$67,000	\$67,000
Total	\$130,000	\$130,000

Note: all figures are GST exclusive.

4.2. Effect of Rights Issue on Capital Structure

A comparative table of changes in the capital structure of ASDM as a consequence of the Offer is set out below, on the basis that the Offer is fully subscribed and in the alternative, on the basis that the Offer is subscribed up to the underwritten amount:

	Offer fully subscribed	Offer subscribed up to the underwritten amount
Shares on issue at date of this Prospectus	43,751,248	43,751,248
Issue of New Shares under the Entitlement Offer	20,125,575	20,000,000
Total Shares on issue after completion of the Offer	63,876,823	63,751,248

The above figures assume that no further Shares are issued prior to the issue of New Shares and Top Up Shares (where applicable) under the Offer. In addition, Shareholders should note that due to rounding of Rights under the Offer to Shareholders on the Record Date, among other things, the exact number of New Shares and Top Up Shares (where applicable) to be issued will not be known until completion of the Offer.

4.3. Effect of Rights Issue on Control of ASDM

The potential effect that the Offer will have on the control of ASDM will depend on various factors and particularly, whether all Eligible Shareholders subscribe for their full Entitlement. If all Eligible Shareholders each subscribe for their full Entitlement, then each Eligible Shareholder's percentage ownership interest (and voting power) in ASDM will remain the same and there will be no effect on the control of ASDM.

If an Eligible Shareholder does not take up all of their Entitlement, its percentage ownership interest (and voting power) in ASDM may be diluted. The proportional percentage ownership interests (and voting power) of Ineligible Shareholders may also be diluted because such Shareholders are not entitled to take up New Shares or Top Up Shares under the Offer.

Where an Eligible Shareholder does not take up all their Entitlement, the proportion of New Shares not taken up forms part of the Top Up Facility and may be allocated to Eligible Shareholders who apply for Top Up Shares. In circumstances where allocations of Top Up Shares are made, then the percentage ownership interest (and voting power) in ASDM of the Eligible Shareholders who are allocated Top Up Shares will increase.

4.3.1. Destin Pty Ltd and Associates

As at the date of this Prospectus, Destin Pty Ltd has a relevant interest in 715,810 Shares, representing 1.31% of the Shares currently on issue.

Destin Pty Ltd is an entity controlled by Peter Kazacos. Peter Kazacos and his wife are the directors of and have a majority controlling shareholding in Destin Pty Ltd.

Peter Kazacos holds 40% of the issued share capital in the Underwriter, Kaz Capital, and is also a director of that company, and so potentially exerts control over that entity (within the meaning of Section 50AA of the Corporations Act).

Destin Pty Ltd has indicated it will subscribe for all New Shares the subject of its Entitlement. Kaz Capital has agreed to underwrite the first \$1,000,000.00 of the Rights Issue to a maximum of \$1,000,000.00 being a commitment of 20,000,000 New Shares.

Kaz Capital under the Underwriting Agreement has agreed to underwrite the first \$1,000,000 of the Rights Issue, however Kaz Capital has appointed Robinwood as sub-underwriter to sub-underwrite the Rights Offer to the same extent of Kaz Capital's obligation under the Underwriting Agreement, namely the first \$1,000,000 of the Rights Issue. In the event that Kaz Capital is liable to subscribe for any shortfall in circumstances where the Sub-Underwriter does not complete the sub-underwriting commitment, then the relevant interest of Destin Pty Ltd and its associates (including Peter Kazacos and the Underwriter) may substantially increase depending upon the take-up of Entitlements by Shareholders. Below is a table detailing various scenarios, which contemplate the situation where Kaz Capital, as Underwriter, is liable to subscribe for the shortfall in circumstances where the Sub-Underwriter does not complete the Sub-Underwriting Agreement:

Destin Pty Ltd and its associates (including Peter Kazacos and the Underwriter)	Total percentage acceptance take-up of Entitlements by Eligible Shareholders including Destin Pty Ltd and its associates				
	100%	75%	50%	25%	0%
Current Shares held	715,810	715,810	715,810	715,810	715,810
Shares to be issued under Underwriting Agreement	0	4,905,819	9,937,213	14,968,606	20,000,000
Shares held assuming the taking up of the full Entitlement	1,045,083	1,045,083	1,045,083	1,045,083	1,045,083
Number of Shares held immediately following the Offer	1,045,083	5,621,629	10,653,023	15,684,416	20,715,810
Percentage of Shares held immediately following the Offer.	1.64%	8.82%	16.71%	24.60%	33.01%

The above table assumes:

- Destin Pty Ltd and its associates (including Peter Kazacos and the Underwriter) take up all of their Entitlement of 20,000,000 New Shares;
- Robinwood does not complete its sub-underwriting commitment.

4.3.2. Sub-underwriter

A. Robinwood and Associates

As at the date of this Prospectus, Nick Hartnell and his associates including the Sub-Underwriter Robinwood have a relevant interest in 8,614,090 Shares, representing 19.69% of the Shares currently on issue.

Robinwood is an entity controlled by Nick Hartnell. Nick Hartnell and his wife are the directors of and have a majority controlling shareholding in Robinwood.

Nick Hartnell has undertaken to ASDM that both he and Robinwood will not subscribe for any New Shares the subject of their respective Entitlement. Robinwood has a sub-underwriting commitment of 20,000,000 New Shares pursuant to the Sub-Underwriting Agreement.

The relevant interest of Nick Hartnell (including the Sub-Underwriter Robinwood) will vary depending upon the take-up of Entitlements of Eligible Shareholders and the subsequent placing of shortfall. Below is a table detailing various scenarios:

Nick Hartnell and his associates (including the Sub-Underwriter Robinwood)	Total percentage acceptance take-up of Entitlements by Eligible Shareholders other than Nick Hartnell and his associates				
	100%	75%	50%	25%	0%
Current Shares held	8,614,090	8,614,090	8,614,090	8,614,090	8,614,090
Shares to be issued as sub-underwriter	0	4,905,819	9,937,213	14,968,606	20,000,000
Number of Shares held immediately following the Offer	8,614,090	13,519,909	18,551,303	23,582,696	28,614,090
Percentage of Shares held immediately following the Offer.	13.51%	21.21%	29.10%	36.99%	44.88%

The above table assumes Nick Hartnell and his associates do not take up any of their Entitlement of 3,962,481.40 New Shares.

B. Sub-sub underwriter

Robinwood has indicated that Dr. Craig Harris has made a verbal commitment to sub-sub-underwrite Robinwood's obligations under the Sub-Underwriting Agreement to a maximum of \$250,000.00 however, there is no formal or binding agreement between Robinwood and Dr. Craig Harris in relation to this verbal commitment.

4.3.3. Intentions of Kaz Capital and Robinwood

Each of Destin Pty Ltd, its associates (including Peter Kazacos and the Underwriter) and Nick Hartnell and his associates (including the Sub-Underwriter Robinwood) may by the Offer increase their relevant interest in Shares and have greater than a 20% relevant interest. They have informed ASDM that on the facts and circumstances presently known to them, they are supportive of our current direction and they do not currently intend to make any major changes to our direction and objectives, and that other than as disclosed in this Prospectus:

- a) do not currently intend to make any significant changes to our existing businesses;
- b) do not currently intend to inject further capital into the Company other than in partly underwriting this Offer. However, if we require additional funding in the future, they will assess such requirement and will decide whether to provide such funding based on the prevailing circumstances at that time;
- c) intend to support our decisions regarding the future employment of our present employees and contemplate that they will continue in the ordinary course of business;
- d) do not currently intend for any property to be transferred between the Company and it or any person associated with it;
- e) do not currently intend to redeploy our fixed assets; and
- f) do not currently intend to change our existing financial or dividend policies.

Destin Pty Ltd and its associates (including Peter Kazacos and the Underwriter) and Nick Hartnell and his associates (including the Sub-Underwriter Robinwood) have indicated that their intentions detailed above are based on the facts and information regarding the Company and the general business environment as at the date of this Prospectus. Any future decision will be reached by them based on all material information and circumstances at the relevant time. Accordingly, if circumstances change or new information becomes available in the future, their intentions may change accordingly.

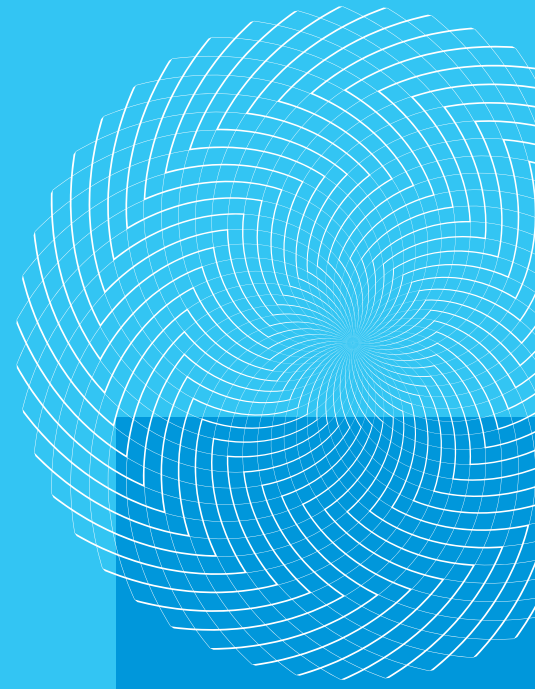
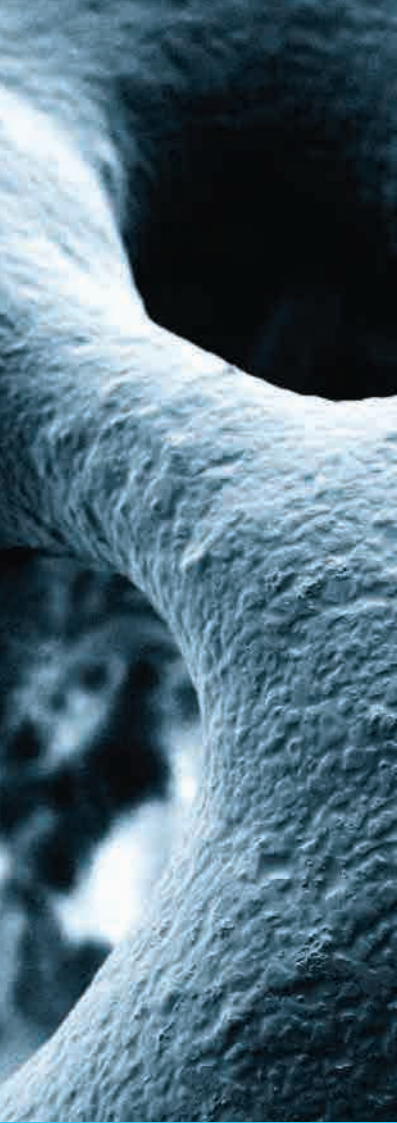

Key Risks

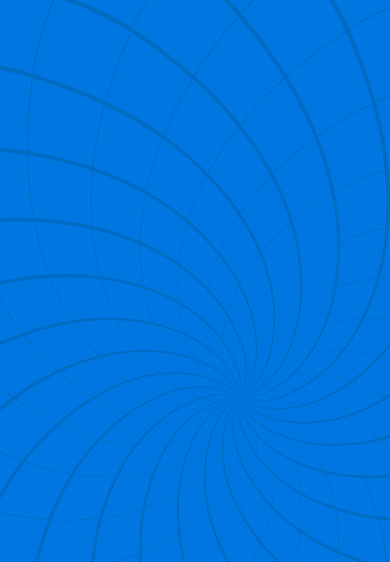
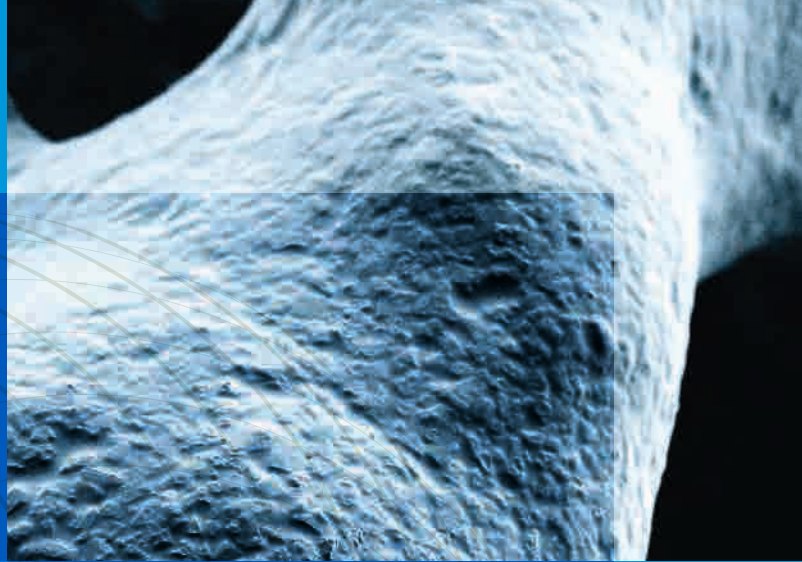

5. Key Risks

ASDM's activities are, and therefore an investment in ASDM is, as with any business, subject to risks that may impact on its future performance.

Shareholders should consider the following summary of risk factors that the Board believes represent some of the general and specific risks associated with Shareholders' decisions on whether to increase their investment in ASDM by taking up their Rights. However, the following summary of risk factors are not intended to be an exhaustive list of all the risks to which ASDM is exposed. Additional risks and uncertainties that ASDM is unaware of, or that it currently considers to be immaterial, may also become important factors that adversely affect ASDM's operating and financial performance.

Shareholders should consider that the investment in ASDM is speculative. The New Shares and Top Up Shares to be issued pursuant to this Offer carry no guarantee with respect to the payment of dividends, returns of capital or the market value of those New Shares and Top Up Shares. Neither ASDM nor the Directors warrant the future performance of ASDM or any return on an investment in ASDM.

Further, the ASX imposes requirements on the continued listing of companies on the ASX, which may be changed from time to time. Investors cannot be assured that ASDM will continue to meet the requirements necessary to maintain a listing on the ASX.

5.1. Specific Risks to ASDM

5.1.1. Market Acceptance of Products

Investors should be aware of the long lead times involved in bringing products to market. The future success of ASDM lies in its ability to get its products and third party supplied products accepted in the marketplace.

The commercial success of ASDM's product range will depend on several factors including the demand for more innovative products than are currently offered by competitors and the establishment of the advantages of ASDM's products. There may be a reluctance by surgeons to use products they have not previously utilised.

5.1.2. Competition

ASDM's current and future potential competitors include certain companies with substantial resources or first-mover advantages. While the Directors are confident about the quality, technical and cost advantages of ASDM's products and proposed products and the intellectual property protecting them, there is no assurance that it will be able to win market share from its competitors, and that its competitors will not succeed in developing products that are more effective or cost effective than ASDM's products. Competitive factors consist primarily of product features and design, innovation, service, the ability to maintain new product flow, relationships with key orthopaedic surgeons and hospitals, strength of distribution network, and price.

5.1.3. Dependence on Route to Market

The business of ASDM is based on relationships with a number of suppliers, distributors, sales agents and through the activities of a number of surgeons. A significant proportion of ASDM's future revenues are expected to be generated through those activities. ASDM's operations are, as a result, dependent on this continuing and, wherever practicable, improving their effectiveness in their respective markets. However, not all of ASDM's distribution arrangements and other activities contain, or will in future contain, minimum sales commitments from those distributors, sales agents and usage by surgeons.

Where counterparties to the exclusive distribution arrangements or sales agencies are incorporated and/ or operate in foreign jurisdictions, enforcement of a breach of the agreements is likely to be expensive and the successful outcome of any legal action is uncertain. Currently, the Directors are unaware of any threatened or potential litigation in respect of any of the exclusive distribution arrangements.

5.1.4. Risk of Product liability and Uninsured Risk

The products manufactured by ASDM are for medical use, often involving implantations in the human body. It is always possible that, notwithstanding the precautions taken by the Company, one or more examples of a product defective in either design or manufacture will cause harm. In this event, ASDM would be, at a minimum, obliged to recall or replace the product, and would very possibly be subject to claims for injury, loss or damage. Such claims would have a direct financial cost and may also damage ASDM's reputation and sales.

ASDM does maintain product liability insurance in the course of maintaining its business. However, there can be no assurance that that insurance will be adequate, or that adequate or necessary insurance coverage will be available at an acceptable cost or in sufficient quantum in the future, if at all, or that product liability or other claims would not materially and adversely affect the business or financial condition of ASDM irrespective of such insurance.

5.1.5. Need for Research and Development and Risk of Rapid Technology Change

The orthopaedic implant industry is subject to rapid technological change and in order for ASDM to remain competitive and to retain market share ASDM must continually develop new products as well as improve its existing ones. Accordingly, ASDM must devote adequate resources to Research & Development. There can be no assurance that ASDM will be successful in developing competitive new products and/or improving existing products so that such products remain competitive and avoid obsolescence. There can be no assurance that any or all of ASDM's Research & Development projects for new products will result in commercial products, or that, if such products are successfully designed and launched, they will be profitable. Similarly, there can be no assurance that stock will not become obsolete in this occurrence.

5.1.6. Dependence on Key Customers

ASDM's business is reliant on business relationships and contracts with a number of key customers. A material proportion of ASDM's future revenues and profits are expected to be generated from such relationships and contracts with key customers and suppliers. Loss or termination of key customers, suppliers or contracts for any reason may have a significant adverse impact on the business, revenues and profitability of ASDM.

5.1.7. Commercialisation of Technology

The commercialisation of technology developed by ASDM could require the licensing of technology to or from other entities. ASDM cannot give an assurance that such licences will be obtained or, if obtainable, will be on commercially acceptable terms. Furthermore there is always the risk that licensing arrangements, once negotiated, could be terminated for reasons that may be beyond ASDM's control.

5.1.8. Effect of Government Regulation

The development, testing, labelling, distribution, marketing and manufacture of medical devices, including implant products, are subject to extensive and rigorous regulation in Australia, the United States of America and other countries. The primary regulatory authority in Australia is the Therapeutic Goods Administration (TGA) and in the United States of America the US Food & Drug

Administration (FDA). The process of obtaining approval of clearance from the TGA and other regulators for the sale and marketing of new products is time-consuming, expensive and uncertain. In addition, regulatory approval or clearance of products can subsequently be withdrawn due to failure to comply with regulatory standards or the occurrence of unforeseen problems following initial marketing. Regulators have the power to ban products manufactured or distributed by ASDM, as well as to require the recall, repair, or replacement of or refund for such products. A significant recall of one or more of its products could have a material adverse effect on ASDM.

Further, changes in government policies particularly in Australia may affect ASDM's revenues and profitability and the value of an investment in ASDM.

5.1.9. New Therapies

It is conceivable that, at some point in the future, an effective treatment for diseases such as rheumatoid arthritis and osteoarthritis will be developed so that primary patient demand for joint replacement devices will be reduced. Any such reduction may have a material adverse effect on ASDM's profitability.

5.1.10. Intellectual Property Risk

The costs of enforcing existing and potential patent rights against infringers, or defending infringement charges by other patent holders may be significant. In addition, no assurances can be given that the patent applications currently pending by ASDM will be granted. Further, all patents have a limited life, and some of ASDM's patents may expire before ASDM is able to fully exploit the exclusivity arising from these patents. In addition, the granting of a patent does not guarantee that the rights of others are not infringed, or that competitors will not develop technology to avoid the patented technology. Thus, the Directors of ASDM must warn Applicants of the vagaries of patents pending and patents currently granted on ASDM products.

5.1.11. International Agreements

ASDM has contractual relations with parties that are domiciled in foreign jurisdictions. There is scope for change in the areas of contract law, property and in particular intellectual property in developing foreign jurisdictions which is outside ASDM's control.

ASDM currently holds the distribution rights for Australia and New Zealand for products manufactured by Small Bone Innovation Inc. with this contract due to expire on 31 December 2014.

As with all distribution agreements there is an inherent risk that contracts may not be renewed.

5.1.12. Business contract risk

There are a number of existing contracts which are material to ASDM's business. Further contracts will likely be entered into by ASDM which will also be material to the ASDM's business.

A number of those contracts are, or will be, governed by laws other than laws of Australia. There may be difficulties in enforcing contracts in jurisdictions other than Australia. Apart from the usual vicissitudes of litigation, there may be regulatory or practical considerations which frustrate the enforceability, or enforcement, of such contracts against foreign or foreign-owned counterparties. These matters may have a significant adverse effect on ASDM's ability to collect payments and otherwise to enforce its contracts, and may have a significant adverse effect more generally on ASDM's business and profitability.

Apart from that, the business dealings of the Company are necessarily exposed to the potential of third party insolvency. If a third party with whom the Company has dealings becomes insolvent, this may also have a significant adverse effect on the Company and on its business and profitability. It should be noted that foreign insolvency laws are not necessarily similar to Australian insolvency laws.

5.1.13. Uncertainty relating to Third Party Reimbursement

Health care providers, including hospitals and orthopaedic surgeons, that purchase ASDM's products, generally rely on third party payers particularly private health insurance plans, to pay for all or a portion of the cost of joint reconstructive procedures, including the cost of ASDM's products utilised in such procedures. There can be no assurance that third party reimbursement for ASDM's products will continue to be available.

5.1.14. Need to Maintain Adequate Inventory Levels

Because orthopaedic surgeons require immediate access to a broad range of sizes and types of reconstructive implant products, the Company is required to maintain adequate levels of inventory. The maintenance of relatively high levels of inventory requires ASDM to incur significant expenditure of its resources. There can be no assurance that ASDM will be able to maintain the levels of inventory of such products necessary to support the expansion of its business. The failure by ASDM to maintain required levels of inventory could have a material adverse effect on ASDM's expansion.

5.1.15. Loss of Key Personnel

ASDM's performance is substantially dependent on its key sales and technical personnel to continue to develop and manage ASDM's products, services and relationships. Competition for such personnel with competitors may be intense. The loss of key personnel could also have a material adverse effect on the business and on its financial performance.

ASDM does not have, nor does it intend to take out, key man insurance in respect of any of its key employees, contractors, senior management and key technical personnel.

The future success of ASDM is also dependent on its ability to attract and retain highly qualified technical, sales and managerial personnel. The inability to attract such personnel may result in a material adverse effect on the business.

5.1.16. Management of growth

ASDM's anticipated growth may place a significant strain on its managerial, operational and financial resources. To manage its potential growth, ASDM must further develop its operational and financial systems. There can be no assurance that ASDM will be able to effectively manage the expansion of its operations, that its facilities, systems, procedures or controls will be adequate to support its operations or that it will be able to achieve the expansion necessary to fully exploit market opportunities. Any inability to manage growth effectively could have a material adverse effect on ASDM's business, results of operations and financial condition.

5.1.17. Speculative Investment

Shareholders should consider that the investment in ASDM is speculative. The New Shares and Top Up Shares (if any) to be issued pursuant to this Offer carry no guarantee with respect to the payment of dividends, returns of capital or the market value of those New Shares and Top Up Shares. Neither ASDM nor the Directors warrant the future performance of ASDM or any return on an investment in ASDM.

5.1.18. Infrastructure and Key Machinery

ASDM relies heavily on its infrastructure and key machinery which is located at St Leonards, NSW Australia. Any breakdown or damage to any of ASDM's key machines or infrastructure could have a material adverse effect on ASDM's manufacturing operations.

5.1.19. Inability to meet debt and contractual obligations

ASDM has external debt and contractual obligations that need to be met. There is a risk that ASDM may be unable to meet its obligations for example due to cashflow constraints and may also be unable to comply with other terms and conditions of these facilities. In that circumstance, ASDM may need to realise one or more of its material assets other than in the ordinary course of business and at values different to those stated in its financial statements.

5.1.20. Government Grant

ASDM has lodged an application for grant funding under the 2014 New South Wales Medical Device Fund program for its innovative synthetic bone scaffold.

At this stage the New South Wales Medical Device Fund expert panel has not determined the successful applicants.

Should ASDM be unsuccessful in its proposed \$1.575m grant application, ASDM will continue to seek alternative funding options to accelerate the project.

5.1.21. Litigation

If ASDM fails to meet its contractual commitments or has other claims made against it, including product liability claims, it may be exposed to litigation that may materially adversely affect the financial position of the ASDM and could negatively impact ASDM through increased costs, payments for damages and damage to its reputation. This is particularly the case in more litigious jurisdictions in which ASDM may carry on business, including the United States of America.

5.1.22. Going Concern

It is likely that further funding will be required to meet the medium to long term working capital costs of ASDM. Even if the Rights Issue is completed successfully, ASDM may require additional funding in the future to develop its business. If such future funding is unable to be obtained by ASDM on acceptable terms, there is a risk as to whether ASDM can continue as a going concern.

5.2. Transaction – specific risks

There are a number of risks associated with the Rights Issue that affect the New Shares and Top Up Shares offered under the Rights Issue.

5.2.1. Failure to complete the Underwriting if the Underwriting Agreement is terminated

If the Underwriting is terminated, ASDM may come under material financial distress and it will be in a less stable financial position and may not be able to continue as a going concern.

If the Underwriting is terminated, the realisation of the benefits that ASDM believes will result from the Rights Issue will be limited and ASDM's operations may not be materially different from its current position or may be materially worse than its current position.

5.2.2. Significant Shareholding of Nick Hartnell and his associates

Following completion of the Offer, Nick Hartnell and his related parties (being the Sub-Underwriter Robinwood) will hold between 13.51% and 44.88% of the issued capital of the Company.

Robinwood is an entity controlled by Nick Hartnell. Nick Hartnell and his wife are the directors of and have a majority controlling shareholding in Robinwood.

Consequently, Nick Hartnell and his related parties will have the ability to influence the election of the Directors, the appointment of new management and the potential outcome of all matters submitted to a vote of the Shareholders. The interests of Nick Hartnell and his related parties may differ from the interests of ASDM and the other Shareholders.

The sale of Shares by Nick Hartnell or his related parties could adversely affect the market price of the Shares.

5.2.3. Significant Shareholding of Destin Pty Ltd and its associates

Following completion of the Offer, Destin Pty Ltd and its associates (being Peter Kazacos and the Underwriter) will hold between 1.64% and 33.01% of the issued capital of the Company (in circumstances where Kaz Capital, as Underwriter, is liable to subscribe for the shortfall where the Sub-Underwriter does not complete the Sub-Underwriting Agreement).

Destin Pty Ltd is an entity controlled by Peter Kazacos. Peter Kazacos and his wife are the directors of and have a majority controlling shareholding in Destin Pty Ltd.

Peter Kazacos holds 40% of the issued share capital in the Underwriter, Kaz Capital, and is also a director of that company, and so potentially exerts control over that entity (within the meaning of Section 50AA of the Corporations Act).

In circumstances where Kaz Capital, as Underwriter, is liable to subscribe for the shortfall where the Sub-Underwriter does not complete the Sub-Underwriting Agreement, Destin Pty Ltd and its associates may have the ability to influence the election of the Directors, the appointment of new management and the potential outcome of all matters submitted to a vote of the Shareholders. The interests of Destin Pty Ltd and its associates may differ from the interests of ASDM and the other Shareholders.

The sale of Shares by Destin Pty Ltd and its associates could adversely affect the market price of the Shares.

5.3. General Investment Risks

Apart from the foregoing, there is a risk that the price of the Shares, and returns to Shareholders, may be affected by the following:

5.3.1. Market Conditions

The market price of the New Shares and Top Up Shares can fall as well as rise and may be subject to varied and unpredictable influences on the market for equities in general.

Share market conditions may affect the value of the ASDM's shares regardless of ASDM's operating performance. Share market conditions are affected by many factors such as:

- a) general economic outlook;
- b) interest rates and inflation rates;
- c) currency fluctuations;

- d) changes in investor sentiment toward particular market sectors;
- e) the demand for, and supply of, capital;
- f) terrorism or other hostilities in Australia or overseas; and
- g) natural disasters in Australia or overseas.

5.3.2. Economic Risks

ASDM is affected by general business cycles and general economic conditions, including but not limited to movements in interest and inflation rates, currency exchange rates, disposable income levels, taxation legislation and consumer sentiment. These factors may have an adverse effect on the ASDM's earnings.

5.3.3. Trading in New Shares and Top Up Shares may not be liquid

There may be relatively few potential buyers or sellers of the New Shares and Top Up Shares on ASX at any time. This may increase the volatility of the market price of the New Shares and Top Up Shares. It may also affect the prevailing market price at which Shareholders are able to sell their New Shares and Top Up Shares (if any). This may result in Shareholders receiving a market price for their New Shares and Top Up Shares (if any) that is less or more than the price that Shareholders paid.



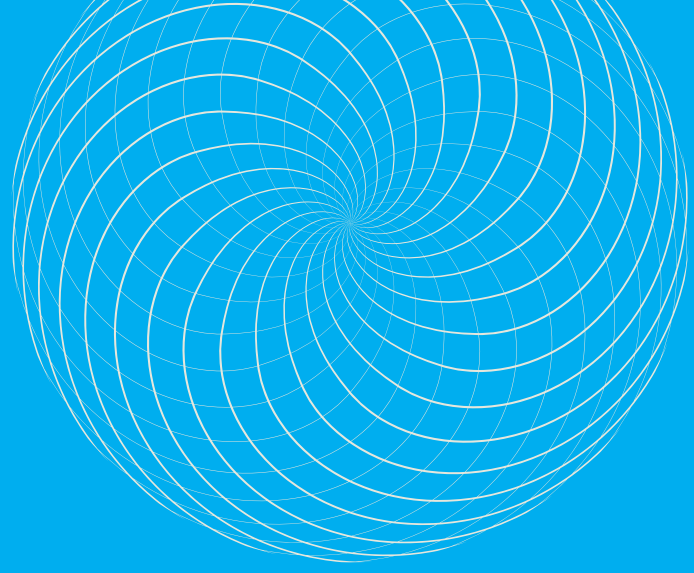

Additional Information

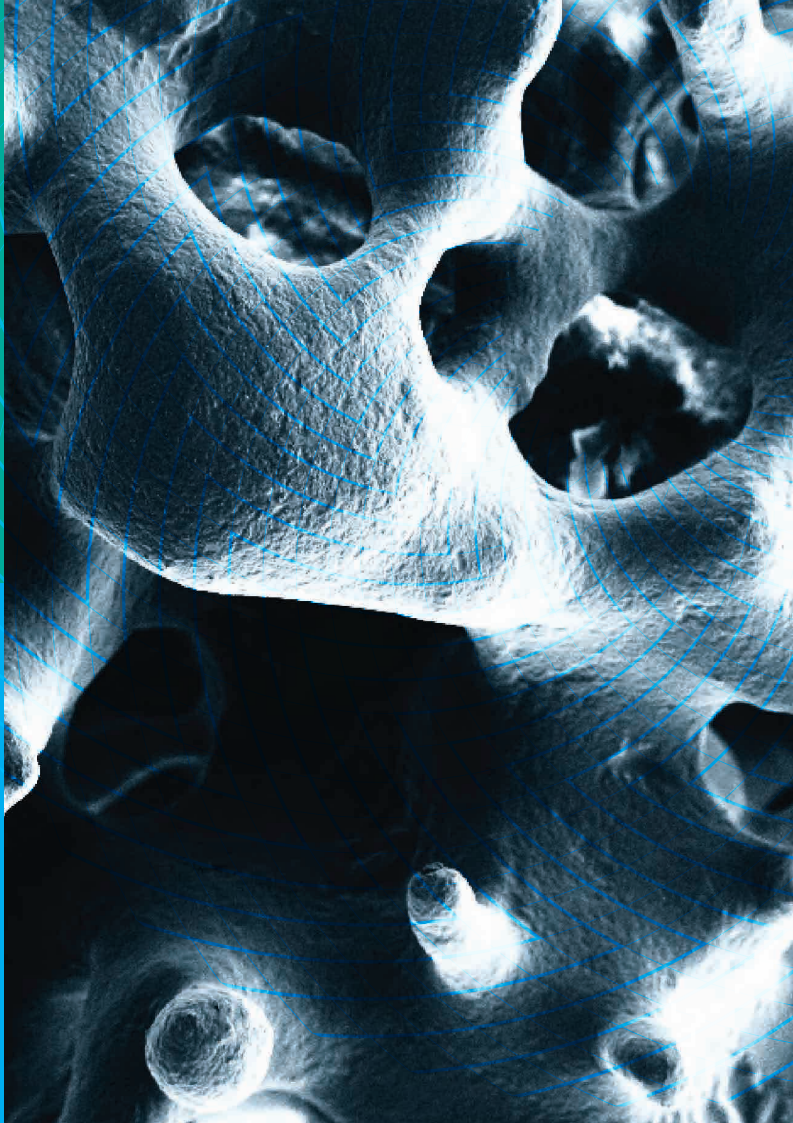
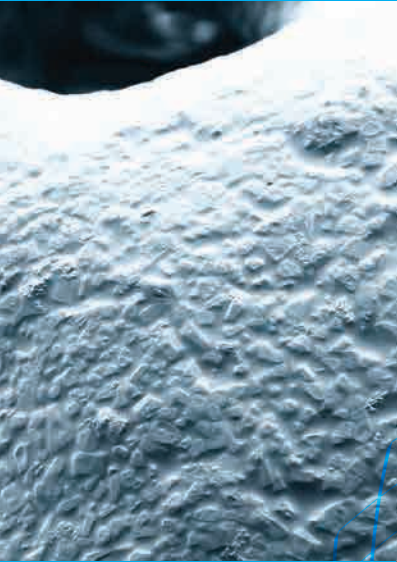

6. Additional Information

6.1. Continuous Disclosure

6.1.1. Disclosing Entity

ASDM is a 'disclosing entity' under the Corporations Act and is subject to regular reporting and disclosure obligations under the Corporations Act and the ASX Listing Rules. Like all listed companies, ASDM is required to continuously disclose any information it has to the market which a reasonable person would expect to have a material effect on the price or the value of the Company's securities. The New Shares and Top Up Shares which will be issued under this Prospectus are in the same class of Shares that have been quoted on the official list of the ASX during the 12 months prior to the issue of the Prospectus.

The Prospectus is a "transaction specific" prospectus to which the special content rules under Section 713 of the Corporations Act apply. That provision allows the issue of a more concise prospectus. A "transaction specific" prospectus is only required to contain information in relation to the effect of the issue of the New Shares and Top Up Shares on the Company and the rights attaching to the New Shares and Top Up Shares. It is not necessary to include general information such as all of the assets and liabilities, financial position, profits and losses or prospects of the company.

This Prospectus is intended to be read in conjunction with the publicly available information in relation to the Company which has been notified to ASX, and does not include all of the information that would be included in a prospectus for an initial public offering of securities in an entity not already listed on a stock exchange. Investors should have regard to that publicly available information before making a decision whether or not to invest.

Having taken such precautions and having made reasonable enquiries, ASDM believes it has complied with the general and specific requirements of the ASX throughout the period from lodgement of ASDM's annual financial statements for the financial year ended 30 June 2013 to the issue of this Prospectus, which required ASDM to notify ASX of information about specified matters as they arise for the purpose of ASX making that information publicly available to the stock market.

6.1.2. Available Documents

Copies of documents lodged with ASIC in relation to the Company may be obtained from, or inspected at, an ASIC office.

If requested, ASDM will provide, free of charge, a copy of each of the following continuous disclosure documents to any person who makes a request for it during the Offer Period:

- ASDM's annual report for the period ended 30 June 2013 (being ASDM's most recent annual report lodged with ASIC before the date of this Prospectus);
- ASDM's half year report for the half year ended 31 December 2013 (being ASDM's most recent half year report lodged with ASIC before the date of this Prospectus); and

- any of the following continuous disclosure documents released to ASX by ASDM after lodgement of ASDM's annual report for the period ended 30 June 2013 and before the lodgement of this Prospectus with ASIC:

Document	Date
Annual Report to Shareholders	26/09/2013
Notice of Annual General Meeting / Proxy Form	27/09/2013
Results of Meeting	30/10/2013
Expiry of Options	21/02/2014
Half Yearly Report and Accounts	27/02/2014
Synthetic Bone Substitute Licence From University of Sydney	02/04/2014
Preliminary Final Report	29/08/2014
Small Bone Innovations	22/09/2014

All requests for copies of the above documents should be addressed to:

Company Secretary
Advanced Surgical Design & Manufacture
Unit 2, 12 Frederick Street
St Leonards NSW 2065

The above documents may also be obtained free of charge from ASX's website (www.asx.com.au). ASDM's ASX code is "AMT".

6.2. Rights and liabilities attaching to New Shares and Top Up Shares

New Shares and Top Up Shares will be fully paid ordinary shares in the capital of ASDM and will rank equally with the Shares already on issue.

The rights and liabilities attaching to Shares are set out in ASDM's Constitution and are regulated by the Corporations Act, the law, the Listing Rules and the ASTC Settlement Rules.

Set out below is certain information relating to the share capital of ASDM, including a brief summary of certain provisions in ASDM's Constitution and the Corporations Act (the governing corporate law of ASDM) in effect at the date of this Prospectus. This summary does not purport to be complete and is qualified in its entirety by reference to ASDM's Constitution and applicable Australian corporate law.

ASDM's Constitution is available for inspection free of charge at ASDM's registered office during normal business hours.

6.2.1. Share capital

The share capital in ASDM consists of fully paid ordinary shares. All existing issued ordinary shares are of the same class and rank equally in all respects.

6.2.2. Voting Rights

Each Share confers the right to vote at meetings of Shareholders, subject to voting restrictions imposed on a Shareholder under the Corporations Act and the ASX Listing Rules. On a show of hands, every Shareholder present in person or by proxy has one vote. On a poll, every Shareholder who is present in person or by proxy has one vote for each fully paid Share held (and a fraction of a vote for partly paid Shares equal to the amount paid up divided by the total amount paid or payable).

6.2.3. Dividends

ASDM'S profits, which the ASDM Directors may from time to time determine to distribute by way of dividends, are payable equally on all the Shares according to the amount paid (not credited) on the Shares.

If the Directors of ASDM make a determination to pay dividends, they may fix the amount, time and method of payment of dividends.

6.2.4. Rights on Winding-up

If ASDM is wound up and there remains a surplus:

- the liquidator may (with the authority of a special resolution), divide among the ASDM Shareholders in kind, the whole or any part of ASDM's property and may, for that purpose, set a value as the liquidator considers fair upon the property to be divided and may determine how the division is to be carried out between the ASDM Shareholders or different classes of ASDM Shareholders; and
- that surplus will be divided amongst the ASDM Shareholders in proportion to the amount paid up on their ASDM Shares.

The liquidator may, with the authority of a special resolution, vest the whole or any part of ASDM's property in trustees on trust for the benefit of the contributors as the liquidator thinks fit, but so that no ASDM Shareholder will be compelled to accept any shares or other securities in respect of which there is any liability.

6.2.5. Transfer of ASDM Shares

Subject to ASDM's Constitution, the Corporations Act, the ASX Listing Rules and the ASTC Settlement Rules, the Shareholder may transfer Shares by an instrument in writing in a form approved by the ASDM Directors. Where the ASX Listing Rules permit ASDM to do so, ASDM Directors may refuse to register a transfer of ASDM Shares. The ASDM Directors will refuse to register any transfers of ASDM Shares where:

- the Corporations Act or the ASX Listing Rules require ASDM to do so, or the transfer is in breach of the ASX Listing Rules; or
- those shares are restricted securities and the transfer is in breach of any restriction agreement in respect of those securities.

6.2.6. Creation and issue of further ASDM Shares

Subject to the provisions of ASDM's Constitution, the ASX Listing Rules, the Corporations Act, and any rights previously conferred on the holders of any existing ASDM Shares, the ASDM Shares are under the control of ASDM Directors and the ASDM Directors may issue or otherwise dispose of further shares on such terms and conditions as the ASDM Directors determine.

ASDM must not issue any ASDM Shares which carry voting rights which, in the opinion of ASX, are inappropriate or confer inequitable representation on the holders of ASDM Shares.

6.2.7. General Meetings

Each Shareholder is entitled to receive notice of, and to attend, general meetings of ASDM and to receive all notices, accounts and other documents required to be sent to Shareholders under ASDM's Constitution, the Corporations Act and the ASX Listing Rules. A Director may call a meeting of Shareholders and Shareholders may also requisition or convene general meetings in accordance with the procedures for Shareholder-initiated meetings set out in the Corporations Act. Shareholders must be given at least 28 days' written notice of any general meeting unless otherwise permitted by the Corporations Act.

6.2.8. Reduction of Share Capital

Subject to the Corporations Act and the ASX Listing Rules, ASDM may reduce its capital in any manner.

6.2.9. Alteration of ASDM Constitution

The ASDM Constitution can only be amended by a special resolution passed by at least 75% of the ASDM Shareholders present and voting at a general meeting. At least 28 days' written notice specifying the intention to propose the resolutions as a special resolution must be given.

6.2.10. Unmarketable parcels

If a Shareholder holds a number of Shares that is less than a marketable parcel (as defined in the ASX Listing Rules), ASDM has the power to sell or dispose of such Shares unless otherwise instructed by the Shareholder. The net proceeds from the sale will be paid to the Shareholder.

6.3. Involvement of Robinwood in Sub-Underwriting

6.3.1. Background

Robinwood is an entity controlled by Nick Hartnell. Nick Hartnell and his wife are the directors of and have a majority controlling shareholding in Robinwood.

As at the date of this Prospectus, Nick Hartnell and his associates including the sub underwriter Robinwood currently hold 19.69% of the shares in ASDM. As noted in **Section 5.2.2**, Robinwood's role in the sub-underwriting may result in the shareholding of Nick Hartnell and his associates including the sub underwriter Robinwood increasing to 44.88%.

The Board is aware of ASIC's position regarding the underwriting/sub-underwriting of rights issues in circumstances where underwriting/sub-underwriting gives rise to a change of control, as set out in ASIC Regulatory Guide 6. The Board is also aware of the statements of the Takeovers Panel on this point, as set out in Guidance Note 17. In broad terms, the concern of ASIC and the Takeovers Panel is that underwriting/sub-underwriting of a rights issue may be structured so that control of a company may pass to an underwriter/sub-underwriter without a takeover bid.

Given the involvement of Robinwood as Sub-Underwriter, the Board has determined it appropriate to set out some details of its consideration of the relevant factors identified by ASIC and the Takeovers Panel.

6.3.2. Relevant factors

The Board considers that the success of any capital raising would be greatly enhanced by demonstrable support from Robinwood. Given that, the Board concluded that the active involvement of Robinwood in the Rights Issue was necessary for the company to raise sufficient funds to accelerate research and development and sales projects and to undertake the corporate re-branding of ASDM.

Prior to selecting Kaz Capital as underwriter and Robinwood as sub-underwriter, the Board had discussions with other parties. At the conclusion of those discussions, the Board concluded that it would be highly unlikely that a satisfactory agreement could be reached with any of those other parties.

In deciding to proceed with the Rights Issue, it was clear that this gave existing Shareholders an opportunity to participate in the capital raising on terms no less favourable than those of the Underwriter and Sub-Underwriter and that it also reduced the risk of the Underwriter and Sub-Underwriter having to take up additional shares.

Whilst making the Rights Issue non-renounceable may increase the risk of New Shares flowing through to Robinwood and Nick Hartnell, the Board believes that given the low liquidity of the Shares, there is unlikely to be a ready market for the trading of Rights. Furthermore, the costs of implementing a renounceable Rights Issue would be prohibitive.

6.4. Material Contracts

6.4.1. Underwriting Agreement

Peter Kazacos is a director of ASDM. Peter Kazacos holds 40% of the issued share capital in Kaz Capital, and is also a director of that company, and therefore it is likely that Kaz Capital would be considered a related party of ASDM. It follows that the Underwriting Agreement is potentially a related party transaction for the purpose of Chapter 2E of the Corporations Act.

The Underwriting Agreement was negotiated on an arms-length basis and the directors independent of Peter Kazacos resolved that the Underwriting Agreement is on reasonable arms-length terms.

Kaz Capital has been appointed to act as Underwriter and has agreed to underwrite the first \$1,000,000.00 of the Offer to a maximum value of \$1,000,000.00 on the terms and conditions of the Underwriting Agreement.

As at the date of this Prospectus, the Underwriter does not beneficially hold any Shares in the Company.

As the Rights Issue is sub-underwritten to the same extent as Kaz Capital's obligations to underwrite the Right Issue under the Underwriting Agreement, and assuming the Sub-Underwriter fulfils its obligations under the Sub-Underwriting Agreement, Kaz Capital should not have to directly subscribe for any of the New Shares. However, in the event that Kaz Capital is liable to subscribe for any shortfall under the Underwriting Agreement in circumstances where Robinwood did not take up its respective commitment under the Sub-Underwriting Agreement, then the relevant interest of Peter Kazacos and his associates (including the Underwriter) may substantially increase depending upon the take-up of Entitlements by Shareholders (see **Section 4.3.1** for further details).

The Board has carefully considered the terms and conditions of the Underwriting Agreement, and consider that the terms and conditions of the Underwriting Agreement would be reasonable if ASDM and Kaz Capital were dealing at "arms length".

6.4.2. Terms and Conditions of Underwriting Agreement

a) The Underwriter and financial capacity

The Underwriter is a related entity to ASDM. Peter Kazacos is a 40% shareholder and director of the Underwriter. It is a specialised financial services provider offering expert Investment Advisory, Corporate Advisory and Managed Funds to domestic and foreign high net worth individuals and institutions.

b) Subscription

Under the Underwriting Agreement, Kaz Capital is obliged to underwrite the first \$1,000,000.00 of the Offer up to a maximum of \$1,000,000.00 ("Capped Amount"). The maximum number of New Shares that the Underwriter is required to subscribe for is therefore 20,000,000 New Shares in the event that no Eligible Shareholder's take up their Entitlement.

c) Fees

The fee payable to the Kaz Capital is equal to 5% of the Capped Amount.

If the Underwriting Agreement is terminated or the Offer does not proceed or is not completed for any reason, ASDM is still required to pay Kaz Capital a fee of \$45,000.00 (excluding GST) for its management of the Rights Issue and reasonable legal costs in accordance with the Underwriting Agreement.

ASDM is also required to reimburse Kaz Capital for all reasonable out-of-pocket expenses.

d) Termination Events

(i) Unqualified Events

Kaz Capital may terminate the Underwriting Agreement by notice in writing to ASDM at any time before completion after Kaz Capital becomes aware of the happening of any one or more of the following events:-

- without the prior written consent of Kaz Capital, ASDM breaches any term of, or fails to perform any obligations under, the Underwriting Agreement;
- the Mandate Letter is terminated for any reason;
- a statement contained in the materials which form part of this Offer is or becomes misleading or deceptive, or such materials omit any information they are required to contain;
- ASIC or any other person conducts any enquiry, investigation or proceedings, or takes any regulatory action or seeks any remedy, in connection with the Offer or the materials which form part of the Offer, or publicly foreshadows that it may do so;
- a new circumstance:
 - I. arises after the date of lodgement of this Prospectus; and
 - II. would have been required by the Corporations Act to be included in the Prospectus if it had arisen before the Prospectus was lodged,

that Kaz Capital reasonably considers to be materially adverse from the point of view of an investor, and which, if known at the time of issue of the Prospectus would have reasonably been expected to be included in the Prospectus;

- ASDM issues, is required to issue, or acting reasonably ought to issue a supplementary or replacement prospectus to comply with Section 719 of the Corporations Act;
- ASDM is prevented from allotting and issuing the New Shares within the time required by the Listing Rules, the Corporations Act, an order of a court of competent jurisdiction or a government agency;
- ASX withdraws, revokes or amends any relevant ASX Listing Rules waivers;
- ASIC withdraws, revokes or amends any waiver, exemption or modification to enable compliance with the Corporations Act;
- any statement or estimate in the materials which form part of the Offer which relates to a future matter is or becomes incapable of being met or, in the reasonable opinion of Kaz Capital, unlikely to be met in the projected timeframe;

- the S&P/ASX 200 Index of ASX closes at a level that is 10% or more below the level at market close on the business day immediately prior to the date of this Agreement for at least two consecutive business days before the settlement date;
- in relation to listing
 - I. ASDM ceases to be admitted to the official list of ASX or the Shares are suspended from official quotation on the ASX (other than a voluntary suspension or trading halt requested by ASDM (with the written consent of Kaz Capital) to facilitate the Offer);
 - II. ASX issues a written statement to ASDM or Kaz Capital or any of their directors, officers, employees or advisors that it will not grant permission for the official quotation of the New Shares;
- approval is refused or not granted, or approval is granted subject to conditions other than customary conditions, to the official quotation of the New Shares on ASX on or before 4.00pm on the settlement date, or if granted, the approval is subsequently withdrawn, qualified or withheld;
- an application is made by ASIC for an order under Part 9.5 of the Corporations Act in relation to the Offer, the materials related to the Offer, or ASIC commences any investigation or hearing under Part 3 of the Australian Securities and Investments Commission Act 2001 (Cth) in relation to the Offer or its related materials;
- ASDM withdraws the Offer or the Offer will not otherwise proceed in accordance with the Underwriting Agreement;
- any event specified in the timetable is delayed by more than two business days without the prior written consent of Kaz Capital (such consent not to be unreasonably withheld or delayed);
- a director of ASDM (in his or her capacity as an officer of a company) is charged with an indictable offence or is disqualified from managing a company under Sections 206B, 206C, 206D, 206E, 206F or 206G of the Corporations Act;
- in relation to debt facilities:
 - I. ASDM breaches, or defaults under, any provision, undertaking covenant or ratio of a material debt or financing arrangement which has a material adverse effect on ASDM; or
 - II. an event of default, potential event of default, review event which gives a lender or financier the right to accelerate or require repayment of the debt or financing or other similar event occurs under or in respect to any such debt or financing arrangement;
- ASDM is or becomes Insolvent;
- A closing certificate which is required to be furnished by ASDM under the Underwriting Agreement is not furnished when required;
- hostilities not presently existing commence (whether war has been declared or not) or a major escalation in existing hostilities occurs (whether war has been declared or not) involving Australia or the declaration by Australia of a national emergency or war or a major terrorist act is perpetrated involving Australia or any diplomatic, military, commercial or political establishment of Australia;
- any government agency commences any enquiry, investigation or proceedings or takes a public regulatory action or seeks any remedy in relation to the Offer or the materials which form part of the Offer against ASDM or any of its directors in their capacity as a director of ASDM, or announces that it intends to take such action; or
- the Sub-underwriting Agreement is terminated for any reason.

(ii) Material Events

Further, Kaz Capital may terminate without cost or liability by notice to ASDM where:

- any information supplied by or on behalf of ASDM to Kaz Capital in relation to ASDM or the Offer is misleading or deceptive;
- any adverse change occurs in the assets, liabilities, financial position or performance, profits, losses or prospects of ASDM including:
 - I. any adverse change in the earnings, future prospects or forecasts of ASDM from those disclosed in the materials related to the Offer;
 - II. any adverse change in the assets, liabilities, financial position or performance, profits, losses or prospects of ASDM from those respectively disclosed in the materials related to the Offer;
- ASDM, the Offer or the materials related to the Offer do not comply with any applicable law or regulatory requirement or there is a contravention by ASDM of the Corporations Act, ASDM's Constitution, or any of the Listing Rules;
- a default by ASDM in the performance of any of its obligations under the Underwriting Agreement occurs;
- a warranty or representation contained in the Underwriting Agreement on the part of ASDM is or becomes incorrect or inaccurate;
- there is introduced or there is a public announcement of a proposal to introduce, into the Parliament of Australia or any State of Australia a new law, or the Reserve Bank of Australia, or any Commonwealth or State authority, adopts or announces a proposal to adopt a new policy (other than a law or policy which has been publicly announced before the date of the Underwriting Agreement), any of which does or is likely to prohibit or regulate the Offer, capital issues or stock markets in a manner which in the reasonable judgment of Kaz Capital would have a adverse effect on the ability of Kaz Capital to promote the Offer or to enforce contracts to issue or allot the New Shares or adversely affect the taxation treatment of the New Shares.
- In relation to disruption in financial markets, where one of the following occurs:
 - I. a general moratorium on commercial banking activities in Australia is declared by the relevant central banking authority Australia, or there is a disruption in commercial banking or security settlement or clearance services in Australia;
 - II. trading in all securities quoted or listed on ASX is suspended or limited in a respect for one day on which that exchange is open for trading or substantially all of a trading day; or
 - III. the occurrence of any other adverse change or adverse disruption to the political or economic conditions or financial markets in Australia or any change or development involving a prospective adverse change in Australian political, economic or financial conditions,

In either case the effect of which is such as to make it impractical to promote the Offer (or any component of the Offer) or to enforce contracts to issue and allot the New Shares.

6.4.3. Sub-underwriting Agreement

The Underwriter has appointed Robinwood as sub-underwriter to subscribe for the shortfall. The Sub-Underwriter's commitment is 20,000,000 shares, being the same extent of Kaz Capital's obligation under the Underwriting Agreement, namely the first \$1,000,000 of the Rights Issue. The fee payable to the Robinwood for sub-underwriting is \$35,000 including GST.

6.4.4. Underwriter Exemption

Section 606 of the Corporations Act restricts persons acquiring a relevant interest in the voting shares of a listed company that exceeds 20%. However, item 13 of Section 611 of the Corporations Act provides an exemption to this restriction where the relevant interest arises from the acquisition of securities by an underwriter or sub-underwriter under a prospectus and the prospectus discloses the effect that the acquisition would have on that person's voting power.

Both the Underwriter and the Sub-Underwriter rely on this exemption.

For further details as to the effect on the control of ASDM, please see **Sections 4.3.1** and **4.3.2** of this Prospectus.

6.4.5. Kaz Capital Mandate

On 2 May 2014 ASDM and Kaz Capital entered into a Mandate Agreement pursuant to which ASDM is to pay to Kaz Capital a sum of \$45,000.00 (excluding GST) for Kaz Capital's management of the Rights Issue.

6.5. Government Grant

ASDM has lodged an application for grant funding under the 2014 New South Wales Medical Device Fund program for its innovative synthetic bone scaffold.

At this stage the New South Wales Medical Device Fund expert panel has not determined the successful applicants.

If ASDM is successful, it will receive up to \$1.575M grant in relation to the above technology.

Should ASDM be unsuccessful in its application, ASDM will continue to seek alternative funding options to accelerate the project.

6.6. Consents

Each of the parties referred to as consenting parties who are named below:

- does not make the Offer;
- has not authorised, and has not caused the issue of this Prospectus;
- has not made any statement in this Prospectus or any statement on which a statement made in this Prospectus is based;
- to the maximum extent permitted by law, expressly disclaims and takes no responsibility for any statements in or omissions from this Prospectus; and
- has given and has not, before the lodgement of this Prospectus with ASIC, withdrawn its written consent to be named in this Prospectus in the form and context in which it is named.

Role	Consenting Party
Underwriter	Kaz Capital Pty Ltd
Sub-Underwriter	Robinwood Investments Pty Limited
Australian Legal Adviser	Law Corporation Proprietary Limited
Share Registry	Link Market Services Limited

6.7. Interests of directors, experts and advisers

Other than as set out below or elsewhere in this Prospectus no:

- Director or proposed Director of ASDM;
- person named in this Prospectus as performing a function in a professional advisory or other capacity in connection with the preparation or distribution of this Prospectus;
- promoter of ASDM; or
- Underwriter to the issue of New Shares or financial services licensee named in this Prospectus as being involved in the issue of New Shares,

holds at the date of this Prospectus or held at any time during the last two years, any interest in:

- the formation or promotion of ASDM;
- property acquired or proposed to be acquired by ASDM in connection with its formation or promotion, or the offer of Shares under the Offer; or
- the offer of Shares.

6.8. Interests of Directors and Proposed Directors

The table below sets out the relevant interests of the Directors and proposed Directors in ASDM's securities as at the date of the Prospectus and following completion of the Rights Issue. Peter Kazacos has advised ASDM that he proposes to take up all of his Rights. Each of the other Directors being Peter Welsh and John O'Meara have advised ASDM that they will not be taking up their respective Rights.

Director	Current Interests	Entitlements under Rights Issue	Shares Post Rights Issue	Shares Post Rights Issue
Peter Kazacos (and his associates including Destin Pty Ltd)	715,810	329,273	1,045,083 (See Note 1)	20,715,810 (See Note 2)
Peter Welsh	7,123,132	3,276,641	7,123,132	7,123,132
John O'Meara	300,000	138,000	300,000	300,000

Note 1: Peter Kazacos' maximum interest post Rights Issue assuming the Sub-Underwriter does complete the sub-underwriting commitment.

Note 2: Peter Kazacos' maximum interest post Rights Issue includes the allocation of the shares to Kaz Capital Pty Ltd pursuant to the Underwriting Agreement, assuming the Sub-Underwriter does not complete the sub-underwriting commitment.

6.9. Experts and advisers

Law Corporation has acted as Australian legal adviser to ASDM. Law Corporation's fees for work in relation to the Rights Issue up to the date of lodgement of this Prospectus will be approximately A\$13,000 (excluding GST and disbursements).

Kaz Capital has acted as Underwriter of the Rights Issue. Details of the Underwriting Agreement and the fees payable to Kaz Capital in relation to the underwriting are set out in Section 6.4.

Robinwood has acted as Sub-underwriter of the Rights Issue. Details of the Sub-underwriting Agreement and the fees payable to Robinwood in relation to the sub-underwriting are set out in Section 6.4.

6.10. ASX waivers and ASIC relief

The Company has confirmed that no waivers from the ASX Listing Rules are required in relation to the Rights Issue. The Company is not relying on any specific ASIC relief in order to conduct the Rights Issue.

6.11. Privacy

By filling out the Entitlement and Acceptance Form to apply for New Shares, Top Up Shares or paying your Application Monies by BPAY®, you are providing personal information to the Company.

The Privacy Act 1988 (Cth) regulates the way the Company collects, uses, disposes, keeps secure and gives people access to their personal information.

The Company is committed to respecting the privacy of your personal information.

The Company collects, holds and uses that personal information in order to process your Application and to administer your Shareholding in the Company, including:

- the Company maintaining a register of Shareholders in accordance with the Corporations Act;
- the Company paying dividends to you;
- the Company communicating with you, such as sending you annual reports, notices of meetings and any other document which the Company wishes to send to you as a Shareholder;
- the Company carrying out general administration including monitoring, auditing, evaluating, modelling data, dealing with complaints and answering queries; and
- the Company complying with its legal and regulatory obligations.

If you do not provide the information requested in the Entitlement and Acceptance Form, the Company may not be able to process or accept your application for New Shares and Top Up Shares.

Your personal information may be provided to ASDM's agents or service providers on the basis that they deal with such information in accordance with ASDM's privacy policy.

The types of agents and service providers that may be provided with your personal information and the circumstances in which your personal information may be disclosed are:

- the Share Registry for ongoing administration of the share register (the Share Registry is contracted by the Company to maintain the register);
- printers and mail houses for the purposes of preparation and distribution of documents to you and for handling mail;
- professional service providers such as lawyers, accountants, auditors, consultants, and other professional advisers for the purpose of administering, and advising on, the New Shares and Top Up Shares and for any associated actions; and
- other companies where the Company believes it is more efficient to outsource services or functions to those companies.

Your personal information may be provided to certain third parties. The types of third parties that may be provided with your personal information, and the circumstances in which your personal information may be disclosed, are:

- your financial adviser or broker (other than your tax file number information) in connection with services provided to you by your adviser or broker;
- government, regulatory authorities or other people when permitted or required by law, such as ASIC or people inspecting the share register in accordance with the Corporations Act;
- ASX; and
- in certain circumstances and with safeguards to respect your privacy, potential or actual purchasers of an interest in ASDM or ASDM's business or any part thereof.

You have the right to gain access to your personal information held by, or on behalf of, ASDM, subject to certain exemptions under the law. A reasonable charge may be applied for providing access to personal information. You can request access to your personal information by telephoning or writing to the Company Secretary as follows:

Company Secretary
Advanced Surgical Design & Manufacture
Unit 2, 12 Frederick Street,
St Leonards NSW 2065
Telephone - +61 2 9439 4448
Facsimile - +61 2 9439 4441

6.12. Australian taxation implications

Taxation implications will vary depending on the specific circumstances of individual Shareholders. Further, tax rules or their interpretation in relation to equity investments may change following the completion of the Rights Issue. You should obtain your own professional advice before concluding on the particular taxation implications that will apply to you if you participate in the Rights Issue.

6.13. Consents to lodgement

Each Director of ASDM consents to the lodgment of this Prospectus with ASIC, and has not withdrawn that consent prior to this Prospectus being lodged.

6.14. Governing law

This Prospectus and the contracts that arise from acceptance of the Applications are governed by the laws applicable in the state of New South Wales and each Applicant submits to the non-exclusive jurisdiction of the courts of New South Wales.

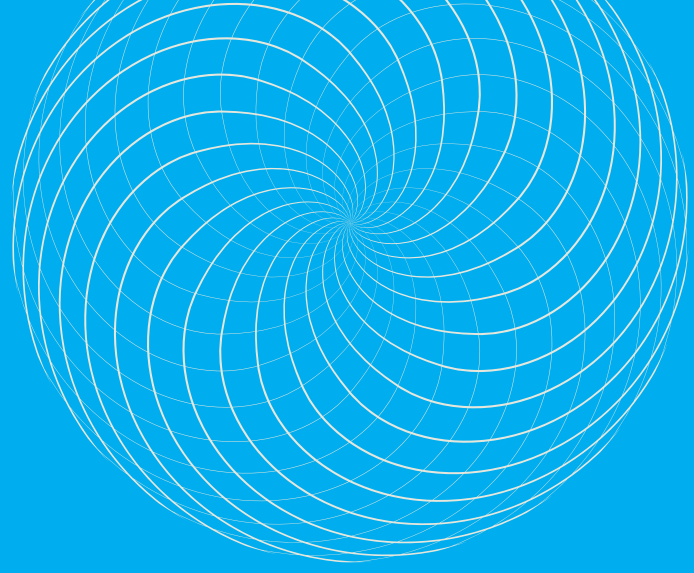

Glossary

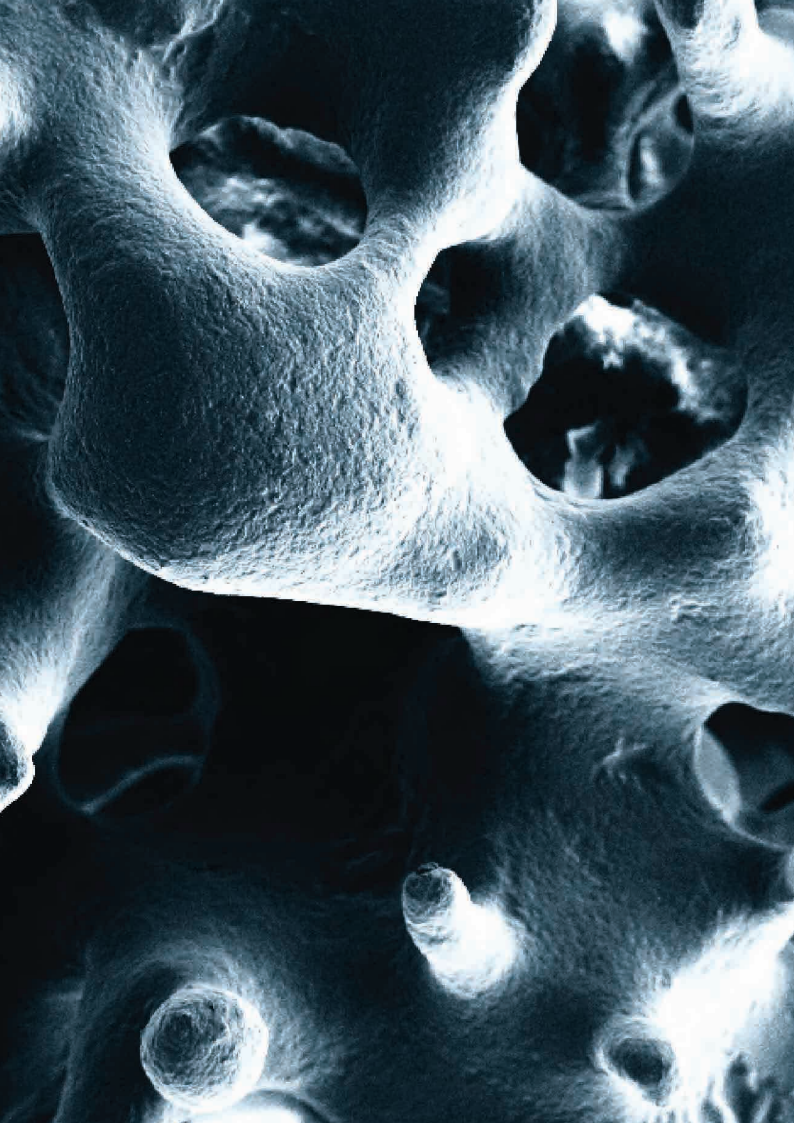
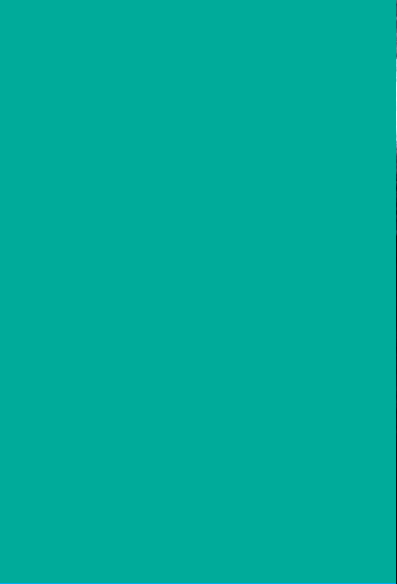
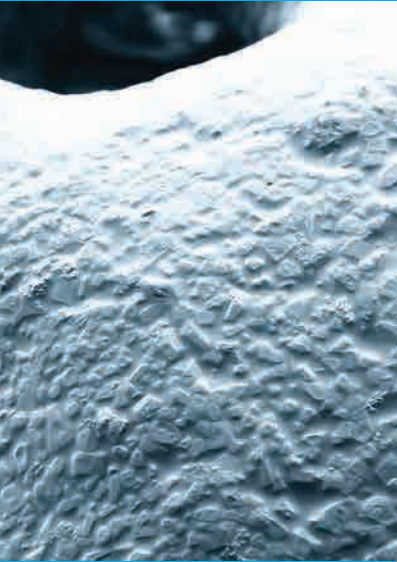

7. Glossary

The following definitions apply throughout this Prospectus unless the context requires otherwise.

AEST	Australian Eastern Standard Time.
ASDM or Company	Advanced Surgical Design & Manufacture Limited ACN 066 281 132.
Applicant(s)	The person(s) who submit valid Entitlement and Acceptance Forms pursuant to this Prospectus.
Application	A valid application made to subscribe for a specified number of Shares pursuant to this Prospectus.
Application Money or Application Amount	The amount payable for New Shares and Top Up Shares (if any) under this Prospectus.
ASIC	Australian Securities and Investments Commission.
ASX	Australian Securities Exchange Limited.
Closing Date	5.00pm (AEST) on 21 October 2014.
Corporations Act	Corporations Act 2001 (Cth) (as amended).
Directors	The Directors of ASDM.
Eligible Shareholders	Shareholders who are not Ineligible Shareholders as at the Record Date.
Entitlement	Offer of 23 New Share(s) for every 50 Shares held by an Eligible Shareholder on the Record Date, subject to the terms of this Prospectus.
Entitlement and Acceptance Form	The form so described and accompanying this Prospectus.
Exposure Period	The period of 7 days after the date of lodgement of this Prospectus, which period may be extended by the ASIC by not more than 7 days pursuant to Section 727(3) of the Corporations Act.
Ineligible Shareholders	The registered holders of Shares on the Record Date with a registered address outside of either Australia or New Zealand.
Kaz Capital	Kaz Capital Pty Ltd (ACN 142 401 429).
Law Corporation	Law Corporation Proprietary Ltd (ACN 136 594 431).

Listing Rules	The official Listing Rules of ASX.
Mandate Letter	The mandate letter between Kaz Capital Pty Ltd and Advanced Surgical Design & Manufacture Limited dated 2 May 2014 whereby Kaz Capital agrees to manage the Rights Issue.
New Shares	Shares that form the Entitlement that is the subject of the Offer contained in this Prospectus.
New Share Price	\$0.05 per New Share.
Offer	The offer of New Shares under the Rights Issue and Top Up Shares under the Top Up Facility (if applicable).
Offer Period	the period commencing on 13 October 2014 and ending on the Closing Date.
Offer Price	\$0.05 per New Share and \$0.05 per Top Up Share.
Prospectus	This Prospectus.
Record Date	7.00pm (AEST) on 7 October 2014.
Rights	The right of an Eligible Shareholder to their Entitlement and to Top Up Shares under the Top Up Facility (where applicable).
Rights Issue	The non-renounceable pro rata offer of New Shares under this Prospectus and the non-renounceable offer to subscribe for Top Up Shares under the Top Up Facility where Eligible Shareholders have subscribed for their full Entitlement.
Robinwood	Robinwood Investments Pty Limited (ACN 162 121 664).
Share(s)	Fully paid ordinary share(s) in ASDM.
Share Registry	Link Market Services Limited ACN 083 214 537.
Shareholder(s)	Means a holder (s) of Shares as at the Record Date.
Top Up Share	Shares available under the Top Up Facility to Eligible Shareholders who take up their full Entitlement under the Rights Issue.
Top Up Facility	Facility consisting of New Shares not taken up by Eligible Shareholders under the Rights Issue.
Top Up Share Price	\$0.05 per Top Up Share

8. Corporate Directory

Advanced Surgical Design & Manufacture Unit 2, 12 Frederick Street, St Leonards NSW 2065 Telephone - +61 2 9439 4448 Facsimile - +61 2 9439 4441 ASX Code – AMT	Share Registry Link Market Services Limited Reply Paid 3560 Sydney NSW 2001
Directors Peter Kazacos (Chairman) Peter Welsh (Managing Director) John O'Meara (Non Exec. Director)	Company Secretary Richard R Ulrick
Underwriter Kaz Capital Pty Ltd Level 6, 88 Foveaux Street Surry Hills NSW 2010	Sub-Underwriter Robinwood Investments Pty Ltd ACN 162 121 664 C/ - Gillespies (Southern Highlands) Pty Ltd Suite 5, 20 Bundaroo Street Bowral NSW 2576
Australian Legal Adviser Law Corporation Proprietary Limited Level 6, 88 Foveaux Street Surry Hills NSW 2010	

Authorisation

This Prospectus is authorised by each Director of the Company under Section 720 of the Corporations Act and signed by Peter Welsh on 26 September 2014 under Section 351 of the Corporations Act.

Signed for and on behalf of

Advanced Surgical Design & Manufacture

A handwritten signature in black ink, appearing to read 'Peter Welsh', with a long horizontal flourish extending to the right.

This page is left blank intentionally.

